

SITE PLAN

FAR & Tenement Details (Table 4c-1)

Building	No. of Same Bldg	Total Built Up Area (Sq.mt.)	Proposed FAR Area (Sq.mt.) Resi.	Total FAR Area (Sq.mt.)	Total Consumed Additional FAR Area (Sq.mt.)	Tnmt (No.)
1 (DUPLEX NO 2)	1	79.39	79.39	79.39	79.39	01
Grand Total :	1	79.39	79.39	79.39	79.39	01

Proposal Basic Information

Proposal File No.	MNAC/BI/0027/W10/2023
Owner Name	BHARTI KUMARI
Khata No	425
Plot No	1453 (PART)
Village Name	Baliguma
Use	Residential
SubUse	Other Residential Building

AREA STATEMENT MANGO MUNICIPAL CORPORATION		VERSION NO. : 1.0.66
PROJECT DETAIL:		VERSION DATE: 16/10/2020
Region: JHARKHAND URBAN LOCAL BODIES	Plot Use: Residential	
District: EAST SINGHBHUM	Plot SubUse: Other Residential Building	
Authority: MANGO MUNICIPAL CORPORATION	PlotNearbyReligiousStructure: NA	
Inward No: MNAC/BI/0027/W10/2023	PlotSubPlot No: 1453 (PART)	
Application Type: General Proposal	North: Plot No. - DUPLEX NO. - 1	
Project Type: Building Permission	South: Plot No. - DUPLEX NO. - 3	
Nature of Development: New	East: Plot No. - SHIKHA SHARMA	
Location of Development Area: Old Area	West: Road Width - 6.1	
AREA DETAILS:		SQ.MT.
AREA OF PLOT (Minimum)	(A)	67.72
NET AREA OF PLOT(Gross Plot Area - Deduction from Gross Plot area)	(A-Deductions)	67.72
Deduction for Balance Plot Area(from Gross Plot Area)		
Common Plot		5.19
Total		5.19
BALANCE AREA OF PLOT(Net Plot Area - Recreational/Amenity space)	(A-Deductions)	62.53
PLOT AREA FOR COVERAGE(Net Plot Area)	(A-Deductions)	67.72
Plot Area for FAR (Net Plot Area + Road Widening Area)	(A-Deductions)	67.72
COVERAGE CHECK		
Permissible Coverage area (70.00 %)		47.40
Proposed Coverage Area (51.82 %)		35.09
Total Prop. Coverage Area (51.82 %)		35.09
Balance coverage area (18.18 %)		12.31
FAR CHECK		
Perm. FAR Area (2.500)		169.30
Total Perm. FAR area		169.30
Residential FAR		79.39
Proposed FAR Area		79.39
Total Proposed FAR Area		79.39
Consumed FAR (Factor)		1.17
Balance FAR Area		89.91
BUILT UP AREA CHECK		
Total Proposed BuiltUp Area		79.39
ARCHITECT (Regd)	SATISH KUMAR	
ENGINEER (Regd)		
SUPERVISOR (Regd)		
OWNER (Regd)	BHARTI KUMARI	
DEVELOPMENT AUTHORITY		LOCAL BODY

COLOR INDEX	
PLOT BOUNDARY	Black
ABUTTING ROAD	Green
PROPOSED CONSTRUCTION	Red
COMMON PLOT	Yellow
ROAD WIDENING AREA	Orange
EXISTING (To be retained)	Blue
EXISTING (To be demolished)	Light Blue

Buildingwise Floor FAR Details

Floor Name	Building Name 1 (DUPLEX NO 2)		Total	
	Proposed Built Up Area (Sq.mt.)	Proposed FAR Area (Sq.mt.)	Total Proposed Built Up Area (Sq.mt.)	Total FAR Area (Sq.mt.)
Ground Floor	35.09	35.09	35.09	35.09
First Floor	44.30	44.30	44.30	44.30
Terrace Floor	0.00	0.00	0.00	0.00
Total :	79.39	79.39	79.39	79.39

Building USE/SUBUSE Details

Building Name	Building Use	Building SubUse	Building Structure
1 (DUPLEX NO 2)	Residential	Other Residential Building	Non-Highrise

LTP NAME AND SIGNATURE	STRUCTURAL ENG'S NAME AND SIGNATURE	BUILDER NAME AND SIGNATURE	DIGITAL SIGNATURE
SATISH KUMAR MNAC/DFTMN/0001/2017			

Proposal Basic Information

Proposal File No.	MNAC/BI/0027/W10/2023
Owner Name	BHARTI KUMARI
Khata No	425
Plot No	1453 (PART)
Village Name	Baliguma
Use	Residential
SubUse	Other Residential Building

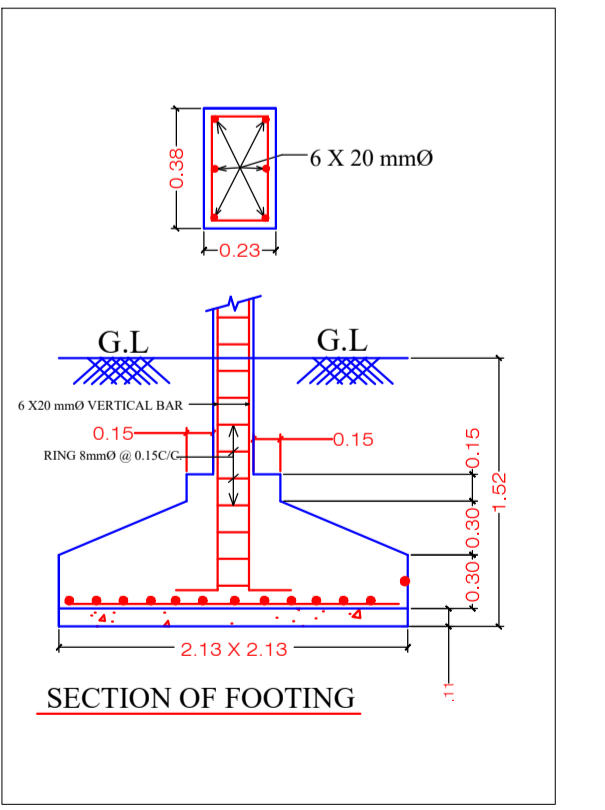
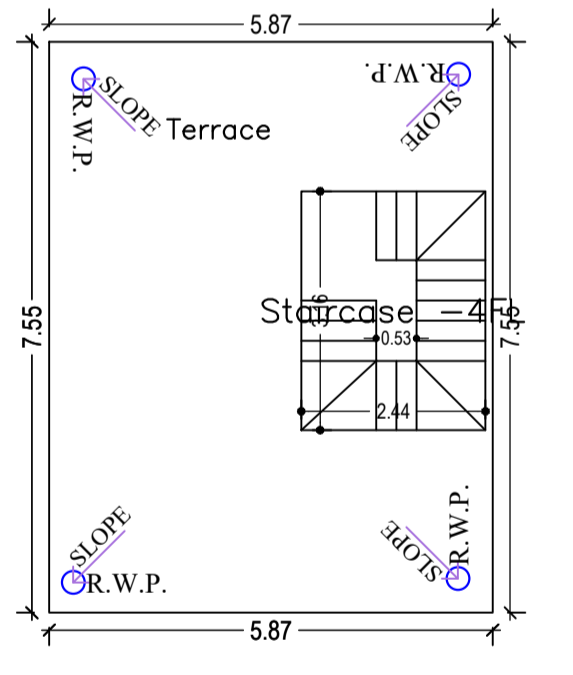
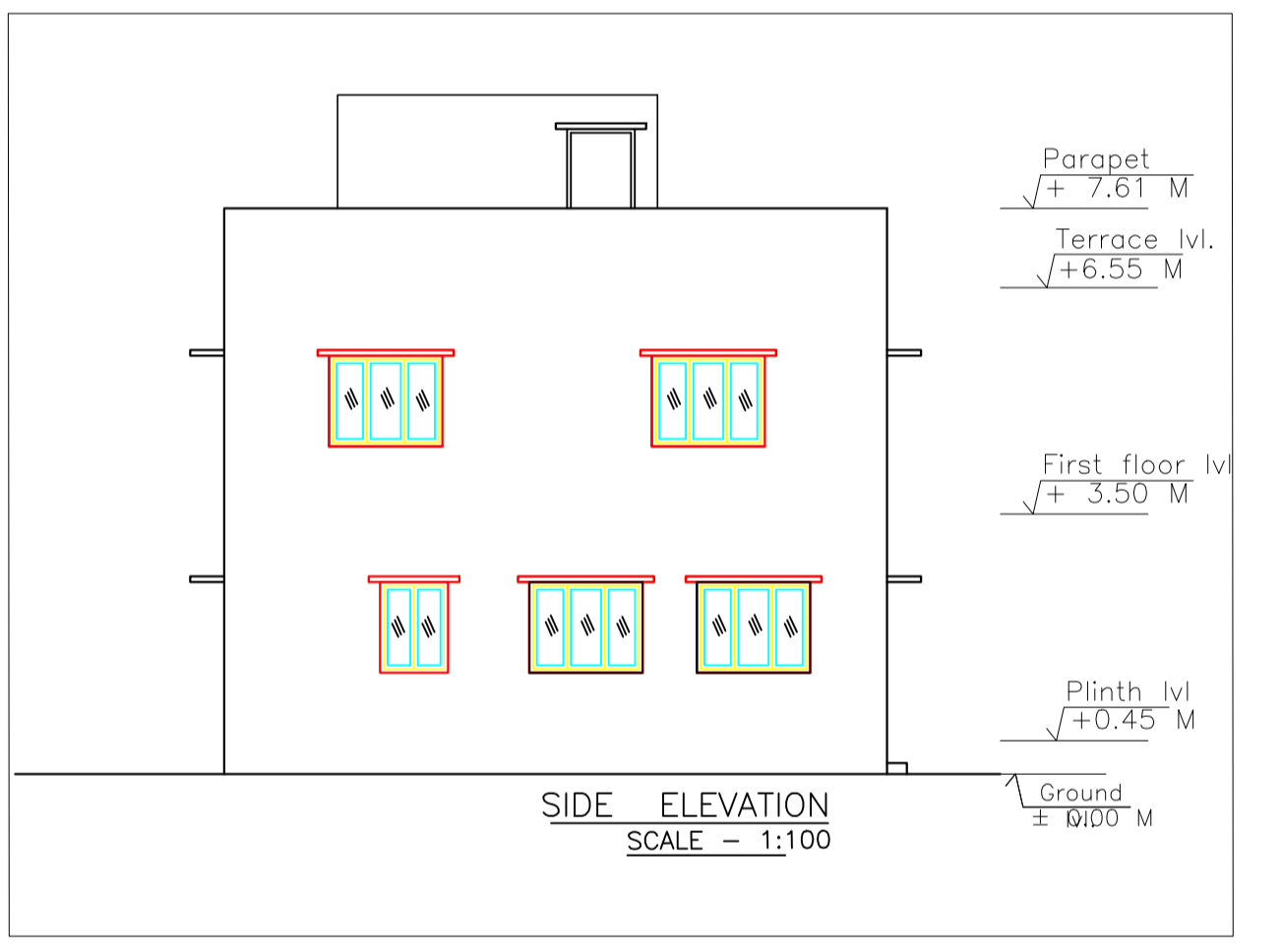
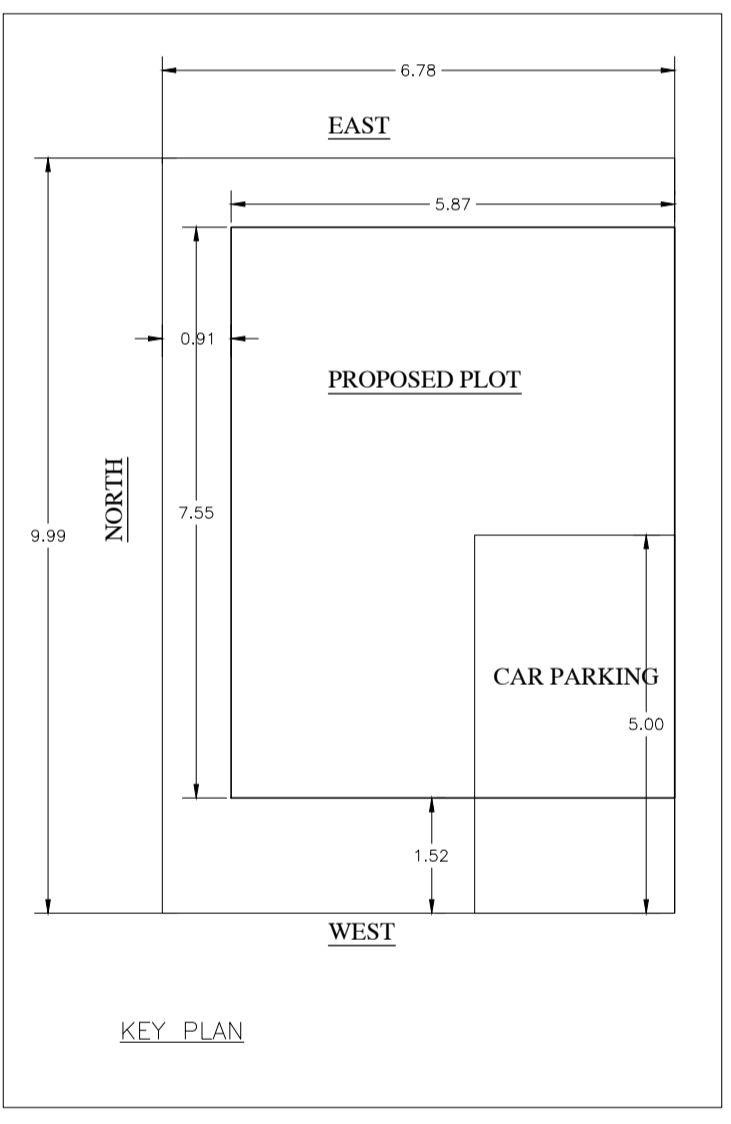
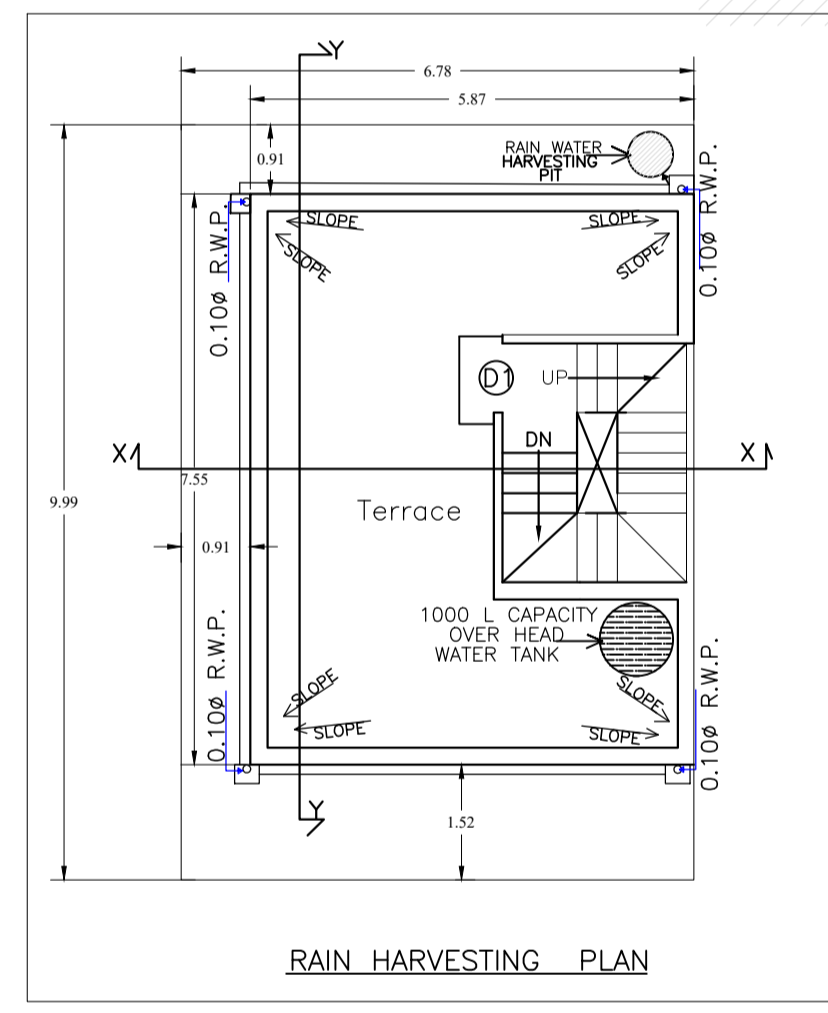
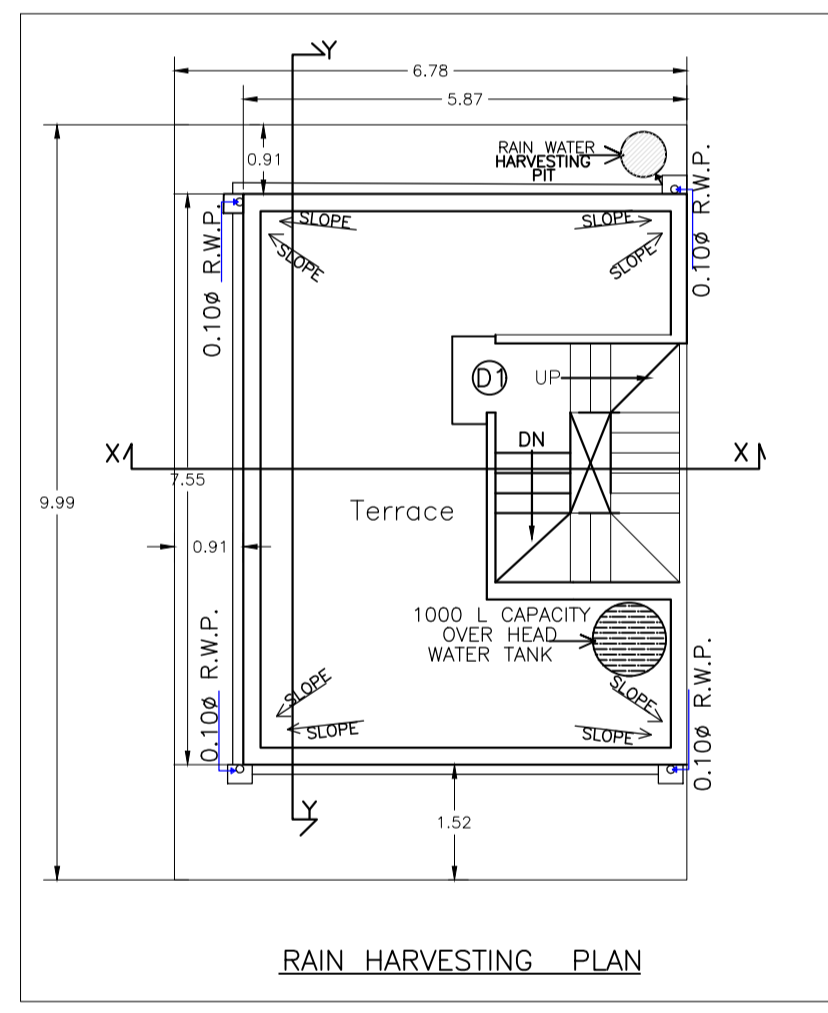
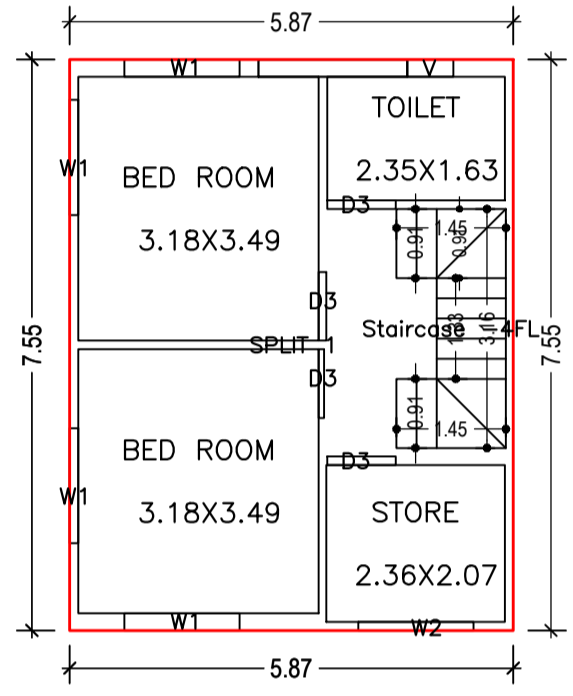
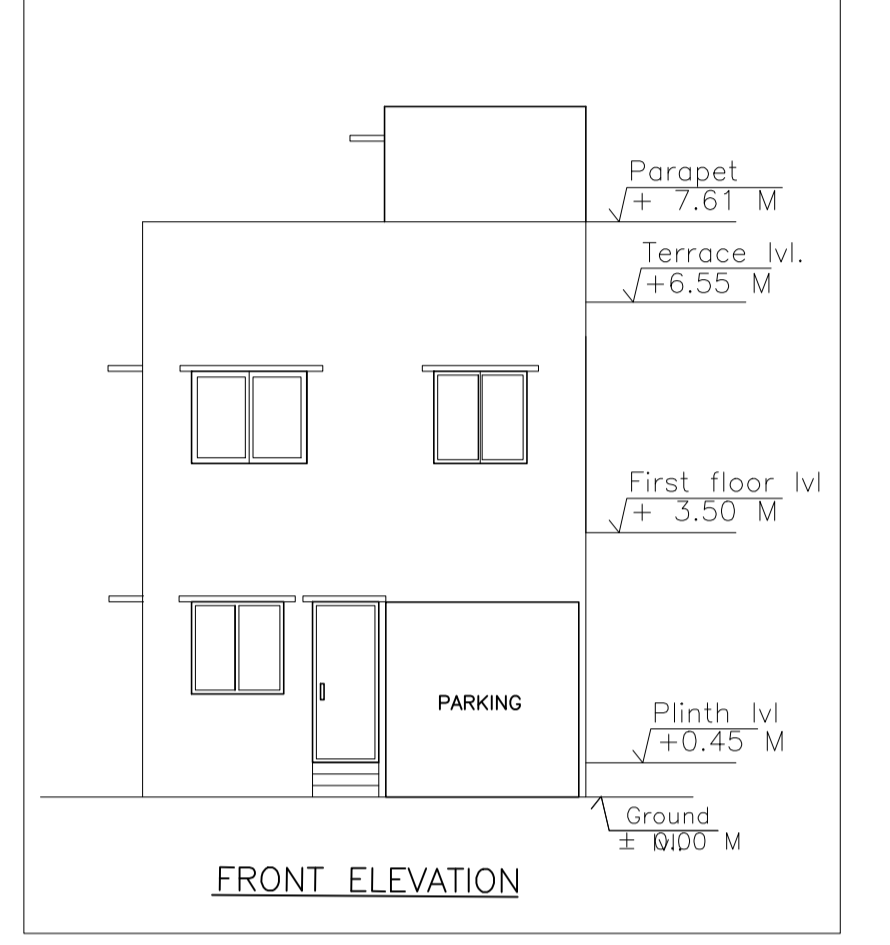
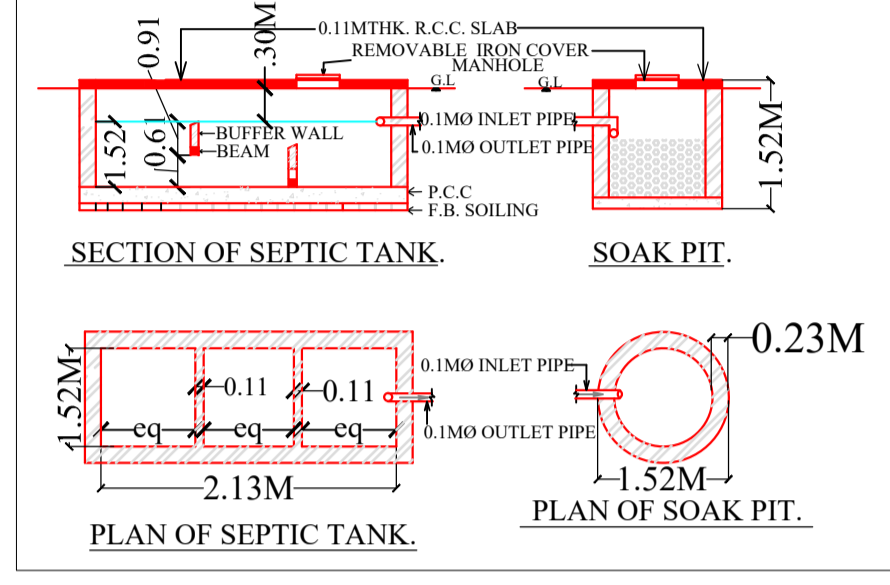
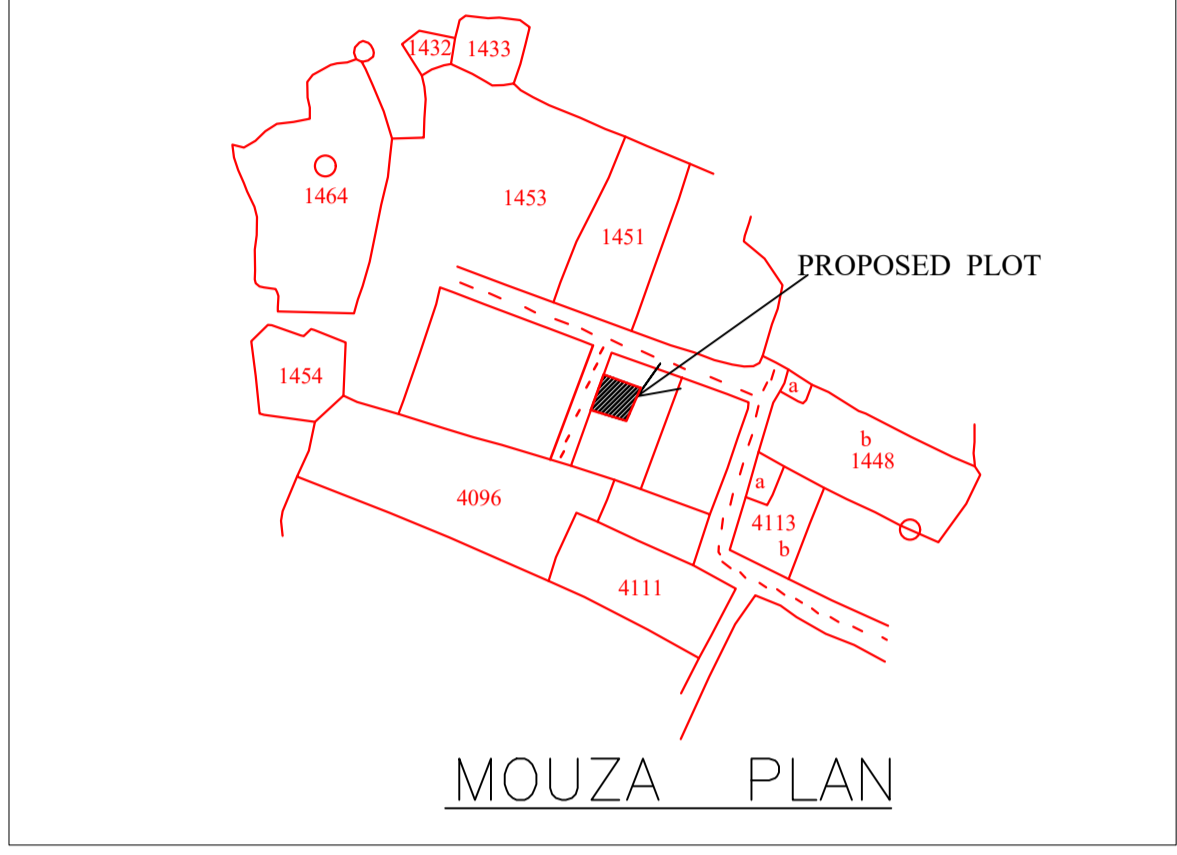
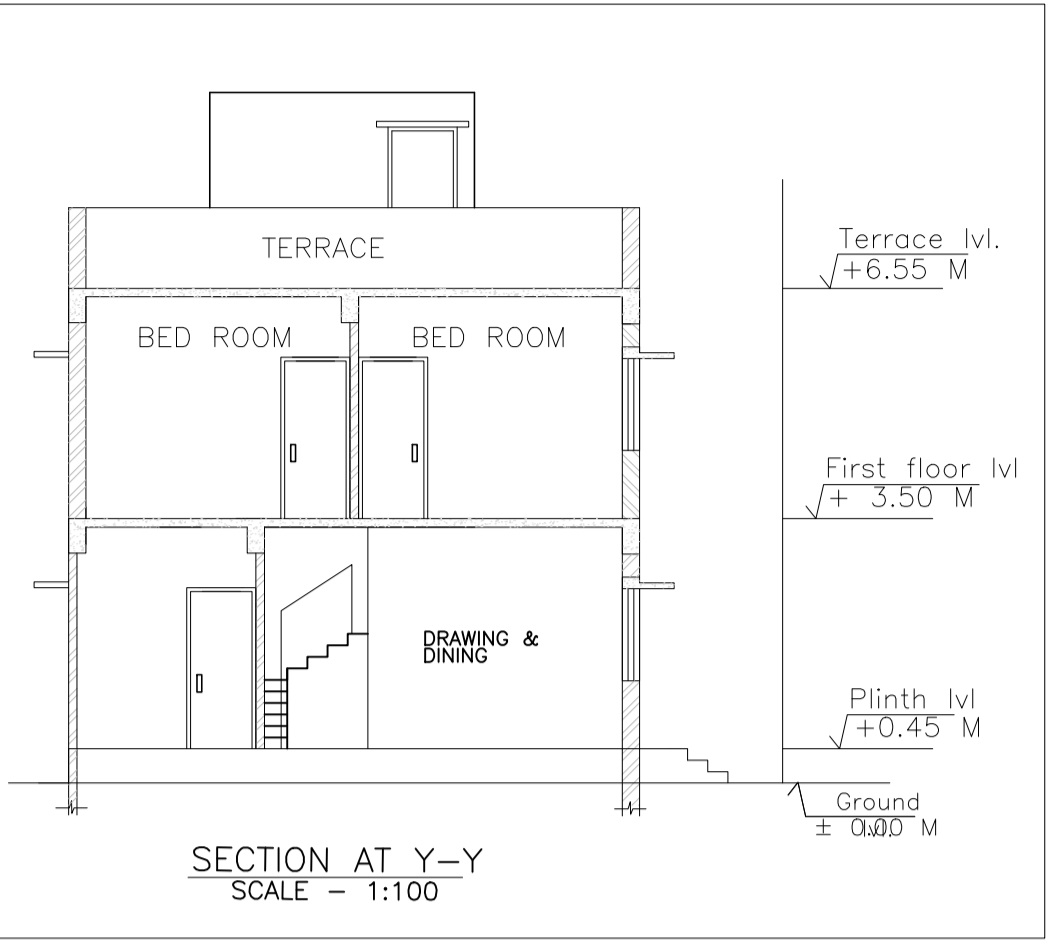
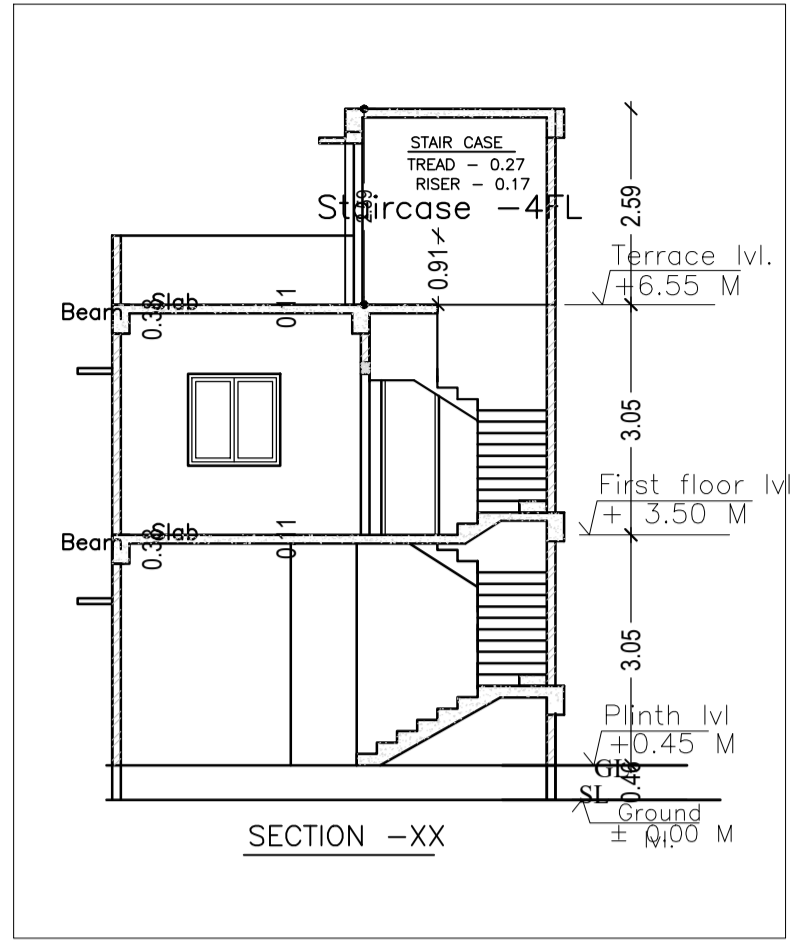
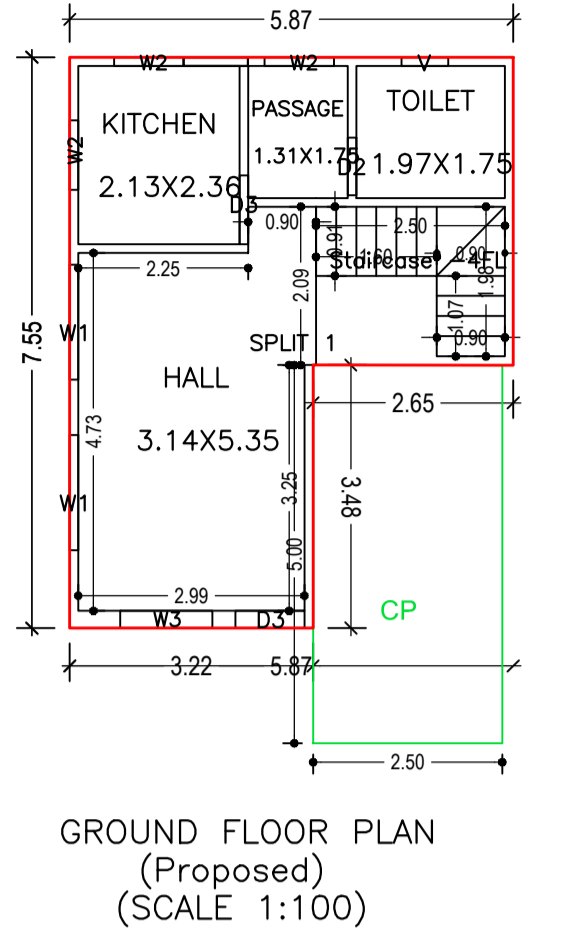

Building :1 (DUPLEX NO 2)

Floor Name	Total Built Up Area (Sq.mt.)	Proposed FAR Area (Sq.mt.)	Total FAR Area (Sq.mt.)	Total Consumed Additional FAR Area (Sq.mt.)	Tnmt (No.)
Ground Floor	35.09	35.09	35.09	35.09	01
First Floor	44.30	44.30	44.30	44.30	00
Terrace Floor	0.00	0.00	0.00	0.00	00
Total:	79.39	79.39	79.39	79.39	01
Total Number of Same Buildings	1				
Total:	79.39	79.39	79.39	79.39	01

SCHEDULE OF DOOR:

BUILDING NAME	NAME	LENGTH	HEIGHT	NOS
1 (DUPLEX NO 2)	D2	0.76	2.10	01
1 (DUPLEX NO 2)	D3	0.91	2.10	06

SCHEDULE OF WINDOW/VENTILATION:

BUILDING NAME	NAME	LENGTH	HEIGHT	NOS
1 (DUPLEX NO 2)	V	0.61	1.20	01
1 (DUPLEX NO 2)	V	0.62	1.20	01
1 (DUPLEX NO 2)	W2	0.92	1.20	03
1 (DUPLEX NO 2)	W3	1.22	1.20	01
1 (DUPLEX NO 2)	W1	1.52	1.20	06
1 (DUPLEX NO 2)	W2	1.52	1.20	01

UnitBUA Table for Building :1 (DUPLEX NO 2)

FLOOR	Name	UnitBUA Type	UnitBUA Area	Carpet Area	No. of Rooms	No. of Tenement
FIRST FLOOR PLAN	SPLIT 1	FLAT	0.00	0.00	4	0
GROUND FLOOR PLAN	SPLIT 1	FLAT	79.39	78.84	4	1
Total:	-	-	79.39	78.84	8	1

LTP NAME AND SIGNATURE	STRUCTURAL ENG'S NAME AND SIGNATURE	BUILDER NAME AND SIGNATURE	DIGITAL SIGNATURE
SATISH KUMAR MNAC/DFTMN/0001/2017			