

SITE PLAN
SCALE 1:100

SITE PLAN

FAR & Tenement Details (Table 4c-1)

Building	No. of Same Bldg	Total Built Up Area (Sq.mt.)	Deductions (Area in Sq.mt.)		Proposed FAR Area (Sq.mt.)	Add Area In FAR (Sq.mt.)	Total FAR Area (Sq.mt.)	Total Consumed Additional FAR Area (Sq.mt.)	Trmnt (No.)
			Void	Parking					
A (RESIDENTIAL)	1	147.02	1.49	29.90	107.18	8.45	115.63	115.63	01
Grand Total	1	147.02	1.49	29.90	107.18	8.45	115.63	115.63	01

Proposal Basic Information

Proposal File No.	MNAC/BI/0083/W08/2023
Owner Name	MD SHEIKH EQBAL AHMAD
Khata No	329
Plot No	2745
Village Name	Pardih
Use	Residential
SubUse	Bungalow/ Dwelling / Non Apartment

AREA STATEMENT MANGO MUNICIPAL CORPORATION	VERSION NO. : 1.0.66	VERSION DATE: 16/10/2020
PROJECT DETAIL:		
Region: JHARKHAND URBAN LOCAL BODIES	Plot Use: Residential	
District: EAST SINGHBHUM	Plot SubUse: Bungalow/ Dwelling / Non Apartment	
Authority: MANGO MUNICIPAL CORPORATION	PlotNearbyReligiousStructure: NA	
Inward No: MNAC/BI/0083/W08/2023	PlotSubPlot No: 2745	
Application Type: General Proposal	North: -	
Project Type: Building Permission	South: -	
Nature of Development: New	East: -	
Location of Development Area: Old Area	West: -	
AREA DETAILS:		
AREA OF PLOT (Minimum)	(A)	SQ.MT. 128.74
NET AREA OF PLOT(Gross Plot Area - Deduction from Gross Plot area)	(A-Deductions)	128.74
Deduction for Balance Plot Area(from Gross Plot Area)		
Common Plot		12.14
Total		12.14
BALANCE AREA OF PLOT(Net Plot Area - Recreational/Amenity space)	(A-Deductions)	116.59
PLOT AREA FOR COVERAGE(Net Plot Area)	(A-Deductions)	128.74
Plot Area for FAR (Net Plot Area + RoadWidening Area)	(A-Deductions)	128.74
COVERAGE CHECK		
Permissible Coverage area (70.00 %)		90.12
Proposed Coverage Area (57.09 %)		73.50
Total Prop. Coverage Area (57.09 %)		73.50
Balance coverage area (12.91 %)		16.62
FAR CHECK		
Perm. FAR Area (1.800)		231.73
Total Perm. FAR area		231.73
Residential FAR		107.18
Proposed FAR Area		115.63
Total Proposed FAR Area		115.63
Consumed FAR (Factor)		0.90
Balance FAR Area		116.10
BUILT UP AREA CHECK		
Total Proposed BuiltUp Area		147.02
ARCHITECT (Regd)	EJAZ AHMAD	
ENGINEER (Regd)		
SUPERVISOR (Regd)		
OWNER (Regd)	MD SHEIKH EQBAL AHMAD	
DEVELOPMENT AUTHORITY		LOCAL BODY

COLOR INDEX	
PLOT BOUNDARY	Black
ABUTTING ROAD	Green
PROPOSED CONSTRUCTION	Red
COMMON PLOT	Yellow
ROAD WIDENING AREA	Orange
EXISTING (To be retained)	Blue
EXISTING (To be demolished)	Light Blue

Buildingwise Floor FAR Details

Floor Name	Building Name A (RESIDENTIAL)		Total	
	Proposed Built Up Area (Sq.mt.)	Proposed FAR Area (Sq.mt.)	Total Proposed Built Up Area (Sq.mt.)	Total FAR Area (Sq.mt.)
Ground Floor	73.51	43.61	73.51	43.61
First Floor	73.51	72.02	73.51	72.02
Terrace Floor	0.00	0.00	0.00	0.00
Total	147.02	115.63	147.02	115.63

Building USE/SUBUSE Details

Building Name	Building Use	Building SubUse	Building Structure
A (RESIDENTIAL)	Residential	Bungalow/ Dwelling / Non Apartment	Non-Highrise

LTP NAME AND SIGNATURE	STRUCTURAL ENG'S NAME AND SIGNATURE	BUILDER NAME AND SIGNATURE	DIGITAL SIGNATURE
EJAZ AHMAD MNAC/DFTMN/0008/2020			

Proposal Basic Information

Proposal File No.	MNAC/BI/0083/W08/2023
Owner Name	MD SHEIKH EQBAL AHMAD
Khata No	329
Plot No	2745
Village Name	Pardih
Use	Residential
SubUse	Bungalow/ Dwelling / Non Apartment

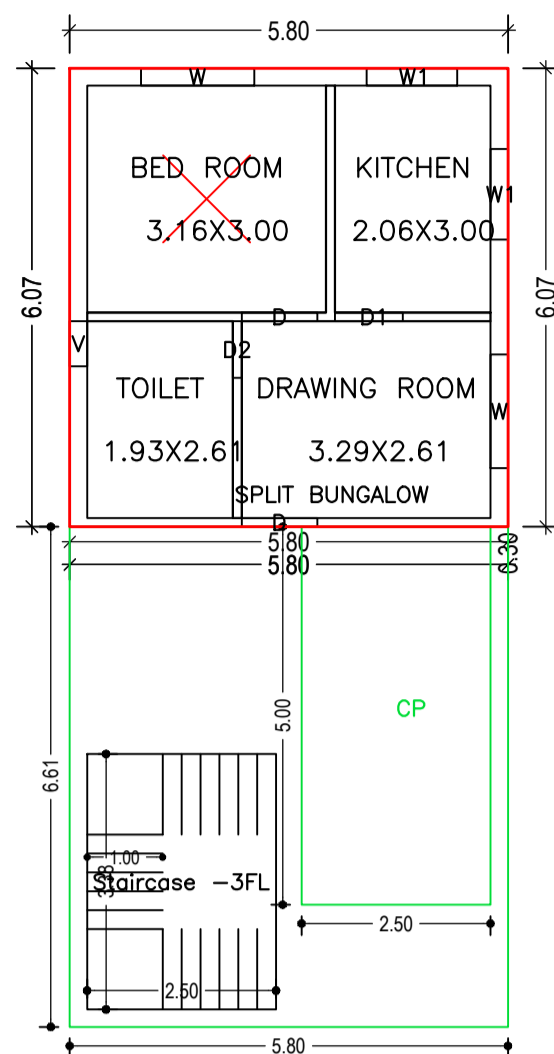

TERRACE FLOOR PLAN (SCALE 1:100)

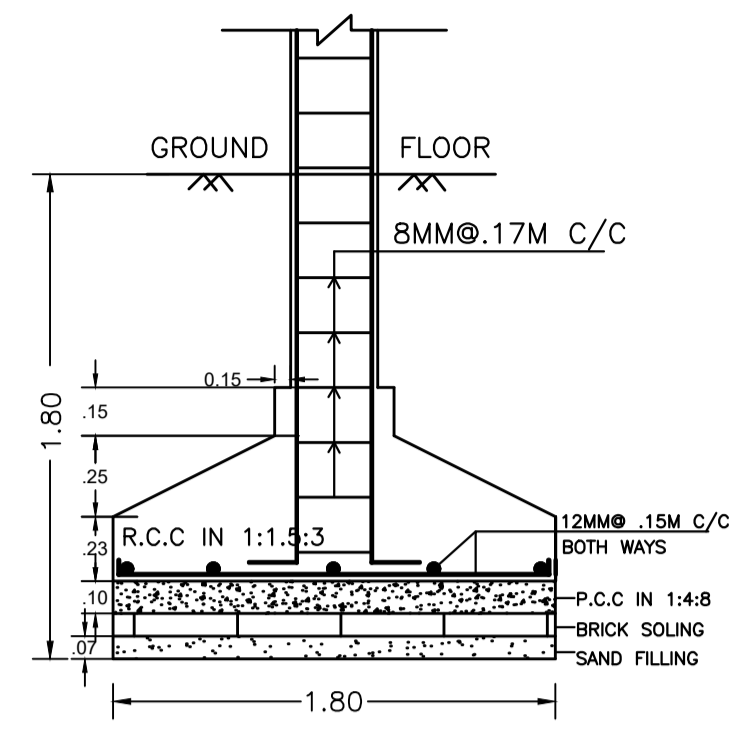

SECTION - CC (SCALE -1:25)

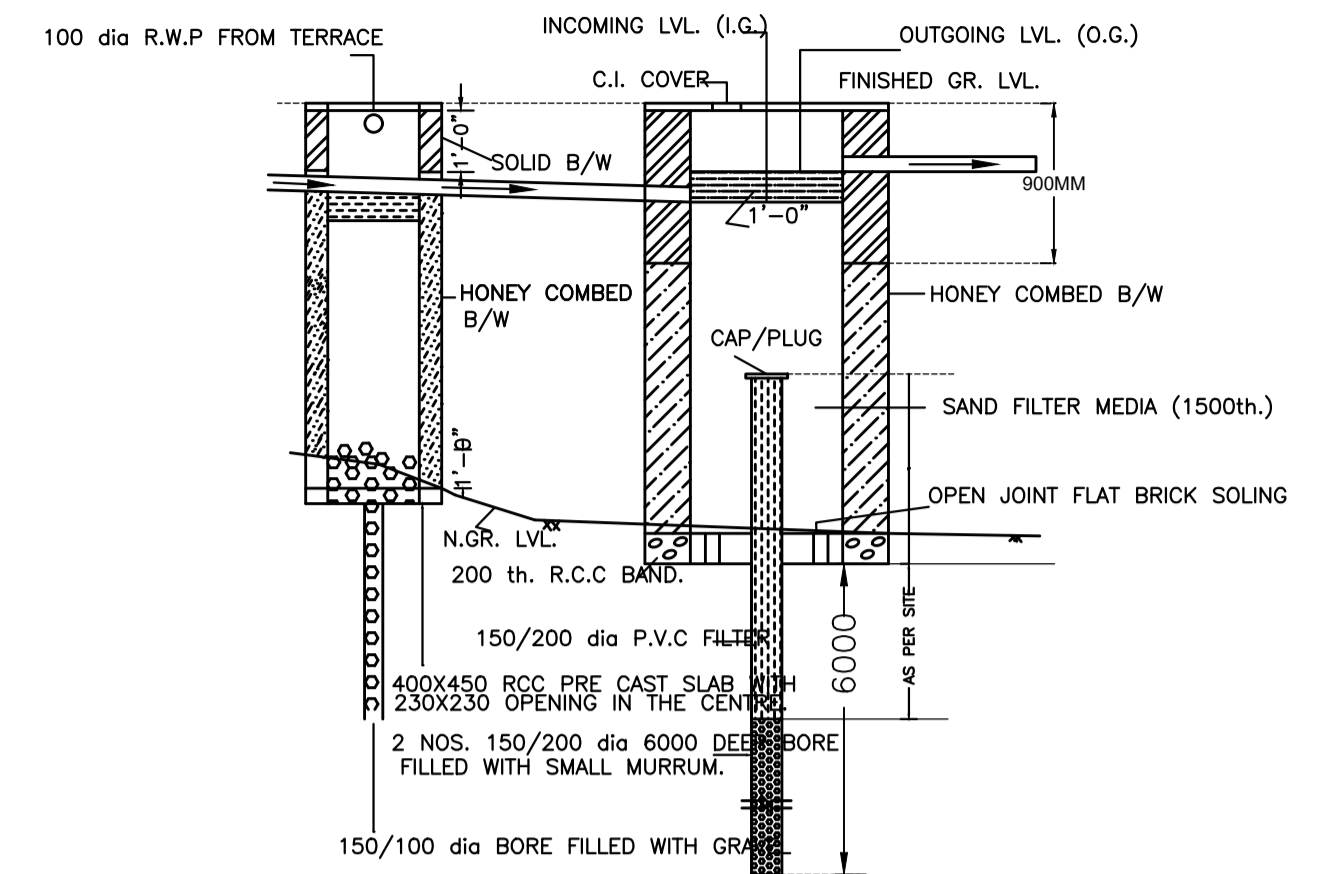

SECTION

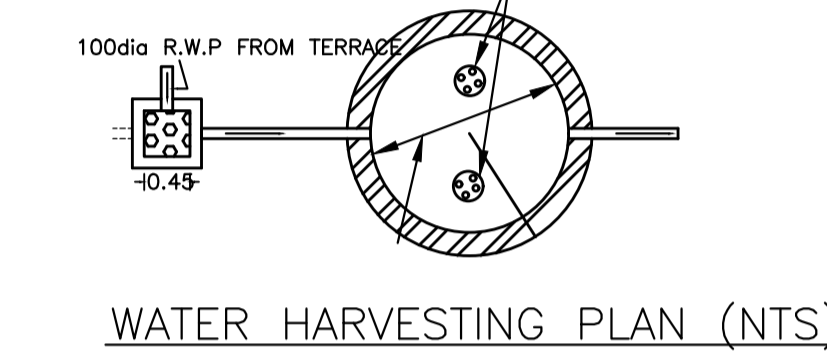

WATER HARVESTING PLAN (NTS)

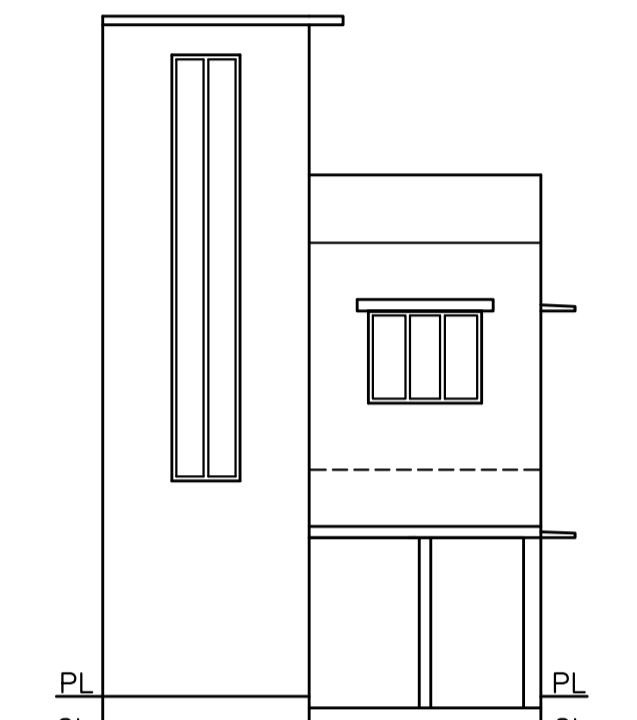

FRONT ELEVATION (SCALE 1:100)

GROUND FLOOR PLAN (Proposed) (SCALE 1:100)

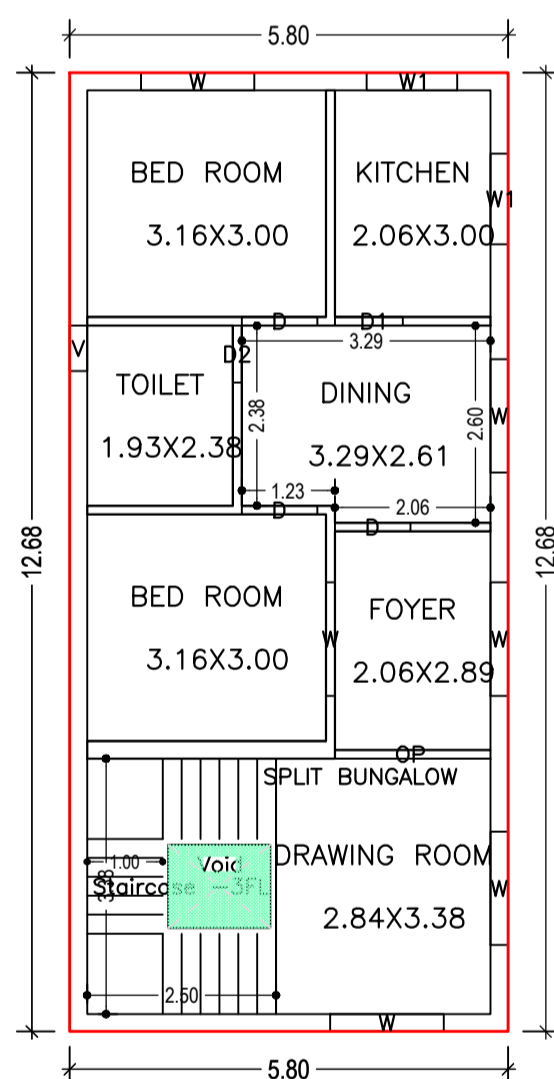

FIRST FLOOR PLAN (Proposed) (SCALE 1:100)

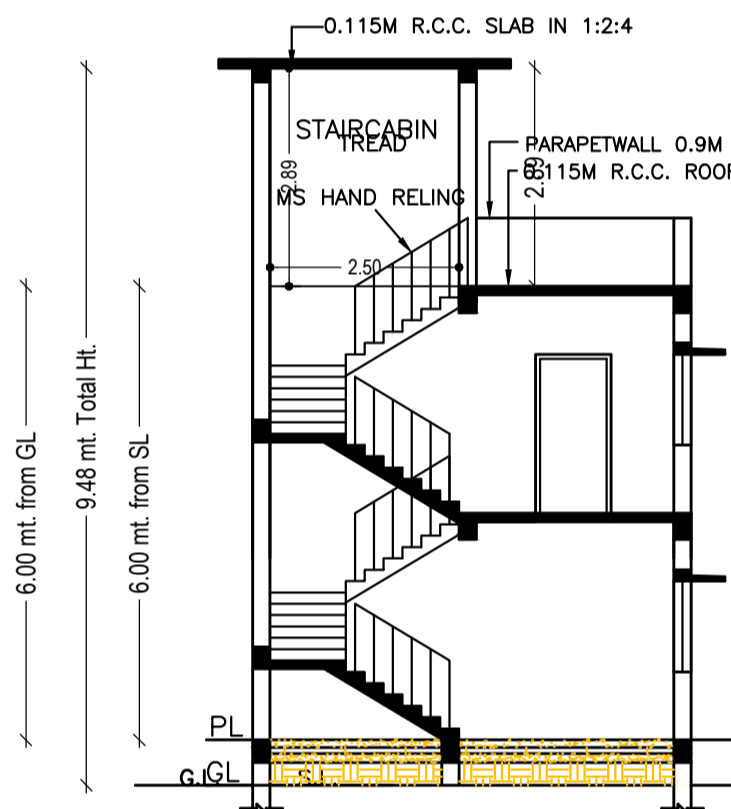

SECTION - AA (SCALE 1:100)

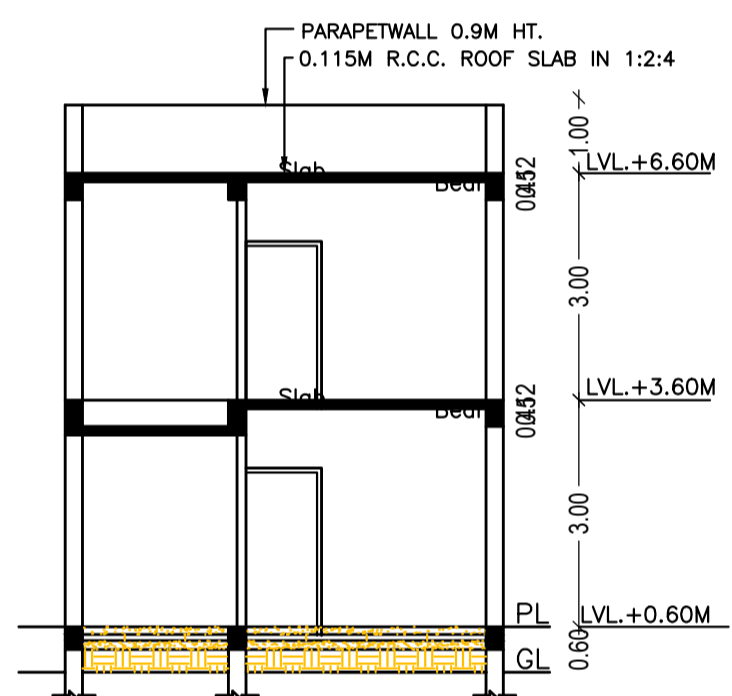

SECTION - BB (SCALE 1:100)

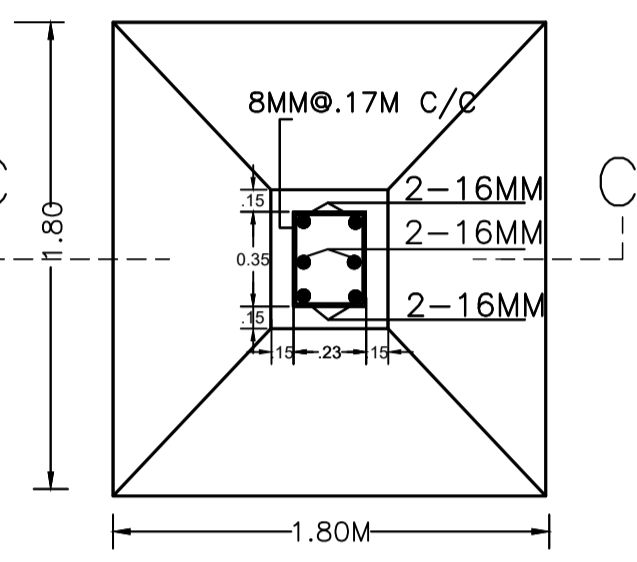

R.C.C. COL. FDN. PLAN (SCALE -1:25)



MOUZA PLAN (NTS)

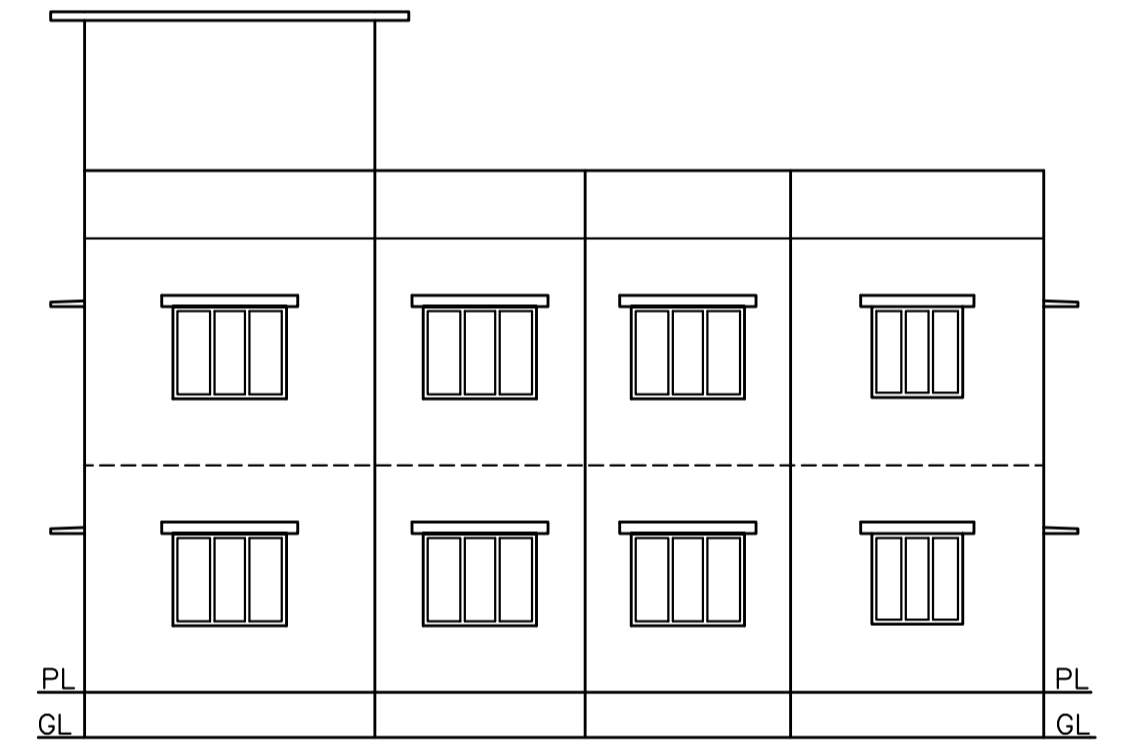

SOUTH SIDE ELEVATION (SCALE 1:100)

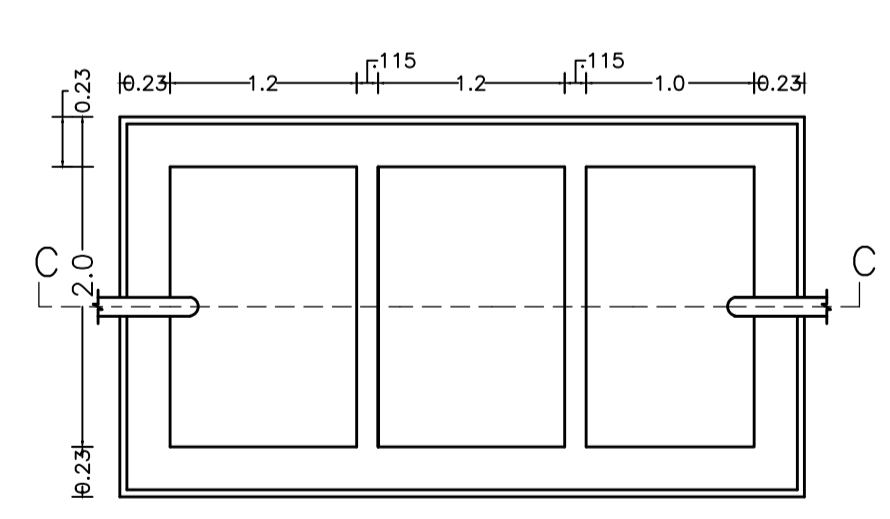

SEPTIC TANK PLAN (SCALE -1:50)

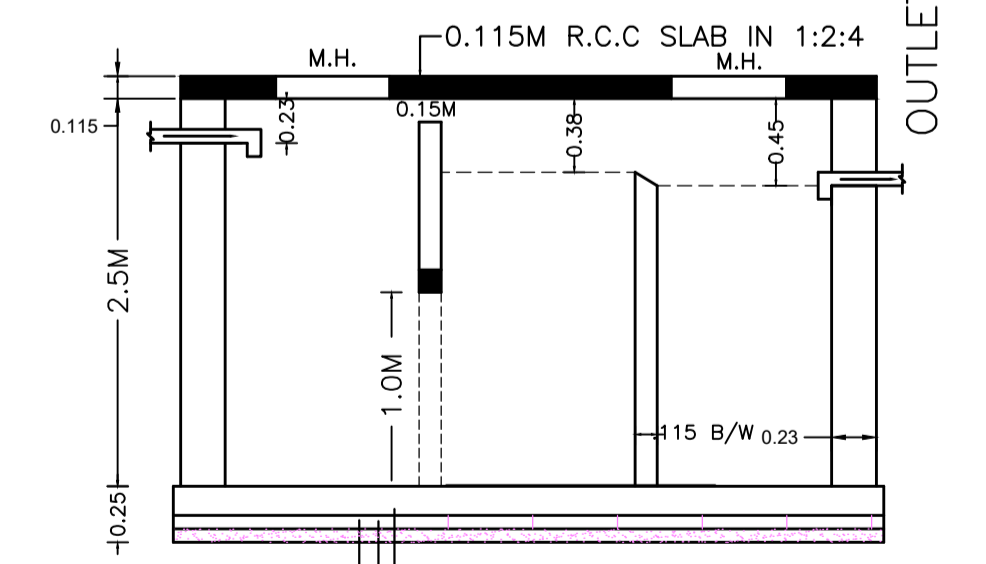

SECTION - SS (SCALE -1:50)

Building :A (RESIDENTIAL)

Floor Name	Total Built Up Area (Sq.mt.)	Deductions (Area in Sq.mt.)		Proposed FAR Area (Sq.mt.)	Add Area in FAR (Sq.mt.)	Total FAR Area (Sq.mt.)	Total Consumed Additional FAR Area (Sq.mt.)	Tnmt (No.)
		Void	Parking					
Ground Floor	73.51	0.00	29.90	35.16	8.45	43.61	43.61	01
First Floor	73.51	1.49	0.00	72.02	0.00	72.02	72.02	00
Terrace Floor	0.00	0.00	0.00	0.00	0.00	0.00	0.00	00
Total:	147.02	1.49	29.90	107.18	8.45	115.63	115.63	01

SCHEDULE OF DOOR:

BUILDING NAME	NAME	LENGTH	HEIGHT	NOS
A (RESIDENTIAL)	D2	0.75	2.10	02
A (RESIDENTIAL)	D1	0.90	2.10	02
A (RESIDENTIAL)	D	1.00	2.10	05
A (RESIDENTIAL)	OP	2.06	2.10	01

SCHEDULE OF WINDOW/VENTILATION:

BUILDING NAME	NAME	LENGTH	HEIGHT	NOS
A (RESIDENTIAL)	V	0.60	0.90	02
A (RESIDENTIAL)	W1	1.20	1.20	04
A (RESIDENTIAL)	W	1.50	1.20	08

UnitBUA Table for Building :A (RESIDENTIAL)

FLOOR	Name	UnitBUA Type	UnitBUA Area	Carpet Area	No. of Rooms	No. of Tenement
GROUND FLOOR PLAN	SPLIT BUNGALOW	FLAT	87.29	83.08	4	1
FIRST FLOOR PLAN	SPLIT BUNGALOW	FLAT	0.00	0.00	7	0
Total:	-	-	87.29	83.08	11	1

LTP NAME AND SIGNATURE	STRUCTURAL ENG'S NAME AND SIGNATURE	BUILDER NAME AND SIGNATURE	DIGITAL SIGNATURE
EJAZ AHMAD MNAC/DFTMN/0008/2020			