

FAR & Tenement Details (Table 4c-1)

Building	No. of Same Bldg	Total Built Up Area (Sq.mt)	Deductions (Area in Sq.mt.)		Proposed FAR Area (Sq.mt.)	Add Area In FAR (Sq.mt.)	Total FAR Area (Sq.mt.)	Total Consumed Additional FAR Area (Sq.mt.)	Trmnt (No.)
			Parking	Resi.					
A (RESIDENTIAL)	1	275.68	75.79	190.06	190.06	9.83	199.89	199.89	01
Grand Total :	1	275.68	75.79	190.06	190.06	9.83	199.89	199.89	01

Proposal Basic Information

Proposal File No.	MNAC/BP/0082/W09/2023
Owner Name	MR. SHAMBHU PRASAD S.O LATE AGNULAL KUMAR
Khata No	617
Plot No	4712
Village Name	Mango
Use	Residential
SubUse	Bungalow/ Dwelling / Non Apartment

AREA STATEMENT MANGO MUNICIPAL CORPORATION		VERSION NO.: 1.0.66	VERSION DATE: 16/10/2020
PROJECT DETAIL:			
Region: JHARKHAND URBAN LOCAL BODIES	Plot Use: Residential		
District: EAST SINGBHUM	Plot SubUse: Bungalow/ Dwelling / Non Apartment		
Authority: MANGO MUNICIPAL CORPORATION	PlotNearbyReligiousStructure: NA		
Inward No: MNAC/BP/0082/W09/2023	Plot/SubPlot No: 4712		
Application Type: General Proposal	North: Plot No - 4711		
Project Type: Building Permission	South: Plot No - 4713, 4714		
Nature of Development: New	East: Road Width - 3.6		
Location of Development Area: Old Area	West: Plot No - 4697		
AREA DETAILS:			
AREA OF PLOT (Minimum)	(A)	SQ.MT.	256.72
Deduction for NetPlot Area			
Surrender Free of Cost			3.25
Total			3.25
NET AREA OF PLOT(Gross Plot Area - Deduction from Gross Plot area)			
(A-Deductions)			253.47
Deduction for Balance Plot Area(from Gross Plot Area)			
Surrender Free of Cost			3.25
Common Plot			36.77
Total			40.02
BALANCE AREA OF PLOT(Net Plot Area - Recreational/Amenity space)			
(A-Deductions)			216.70
PLOT AREA FOR COVERAGE(Net Plot Area)			
(A-Deductions)			253.47
Plot Area for FAR (Net Plot Area + RoadWidening Area)			
(A-Deductions)			256.72
COVERAGE CHECK			
Permissible Coverage area (60.00 %)			152.08
Proposed Coverage Area (54.38 %)			137.84
Total Prop. Coverage Area (54.38 %)			137.84
Balance coverage area (5.62 %)			14.24
FAR CHECK			
Perm. FAR Area (1.200)			308.06
Total Perm. FAR area			308.06
Residential FAR			190.06
Proposed FAR Area			199.89
Total Proposed FAR Area			199.89
Consumed FAR (Factor)			0.78
Balance FAR Area			108.17
BUILT UP AREA CHECK			
Total Proposed BuiltUp Area			275.68
ARCHITECT (Regd)	Chandrika Sharma		
ENGINEER (Regd)			
SUPERVISOR (Regd)			
OWNER (Regd)	MR. SHAMBHU PRASAD S.O LATE AGNULAL KUMAR		
DEVELOPMENT AUTHORITY		LOCAL BODY	

COLOR INDEX	
PLOT BOUNDARY	Black
ABUTTING ROAD	Green
PROPOSED CONSTRUCTION	Red
COMMON PLOT	Yellow
ROAD WIDENING AREA	Orange
EXISTING (To be retained)	Blue
EXISTING (To be demolished)	Light Blue

Buildingwise Floor FAR Details

Floor Name	Building Name A (RESIDENTIAL)		Total	
	Proposed Built Up Area (Sq.mt.)	Proposed FAR Area (Sq.mt.)	Total Proposed Built Up Area (Sq.mt.)	Total FAR Area (Sq.mt.)
Ground Floor	137.84	62.05	137.84	62.05
First Floor	137.84	137.84	137.84	137.84
Terrace Floor	0.00	0.00	0.00	0.00
Total :	275.68	199.89	275.68	199.89

Building USE/SUBUSE Details

Building Name	Building Use	Building SubUse	Building Structure
A (RESIDENTIAL)	Residential	Bungalow/ Dwelling / Non Apartment	Non-Highrise

LTP NAME AND SIGNATURE	STRUCTURAL ENG'S NAME AND SIGNATURE	BUILDER NAME AND SIGNATURE	DIGITAL SIGNATURE
Chandrika Sharma MNAC/DFTMN/0017/2017			

Proposal Basic Information	
Proposal File No.	MNAC/BP/0082/W09/2023
Owner Name	MR. SHAMBHU PRASAD S O LATE AGNULAL KUMAR
Khata No	617
Plot No	4712
Village Name	Mango
Use	Residential
SubUse	Bungalow/ Dwelling / Non Apartment

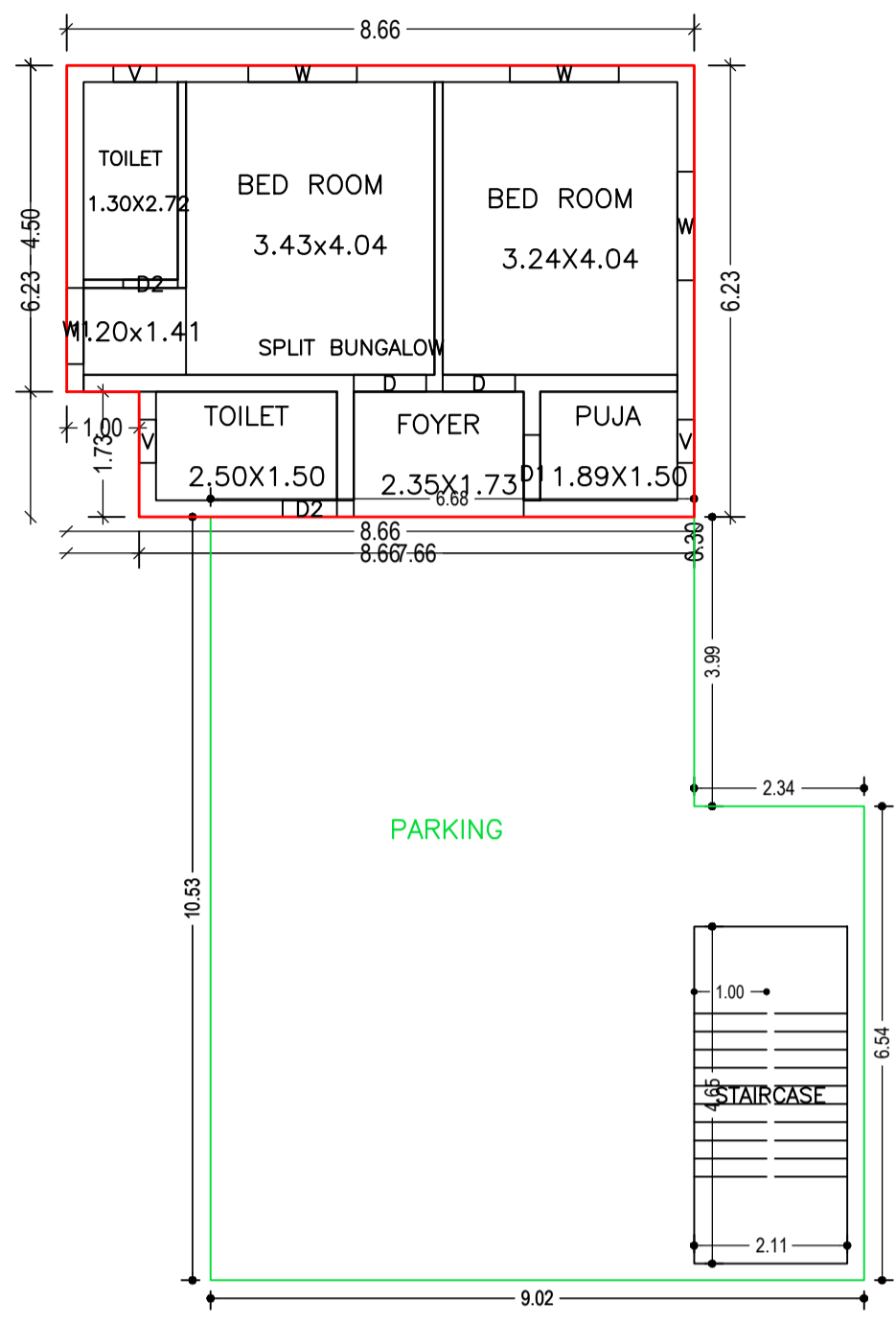

FIRST FLOOR PLAN (Proposed) (SCALE 1:100)

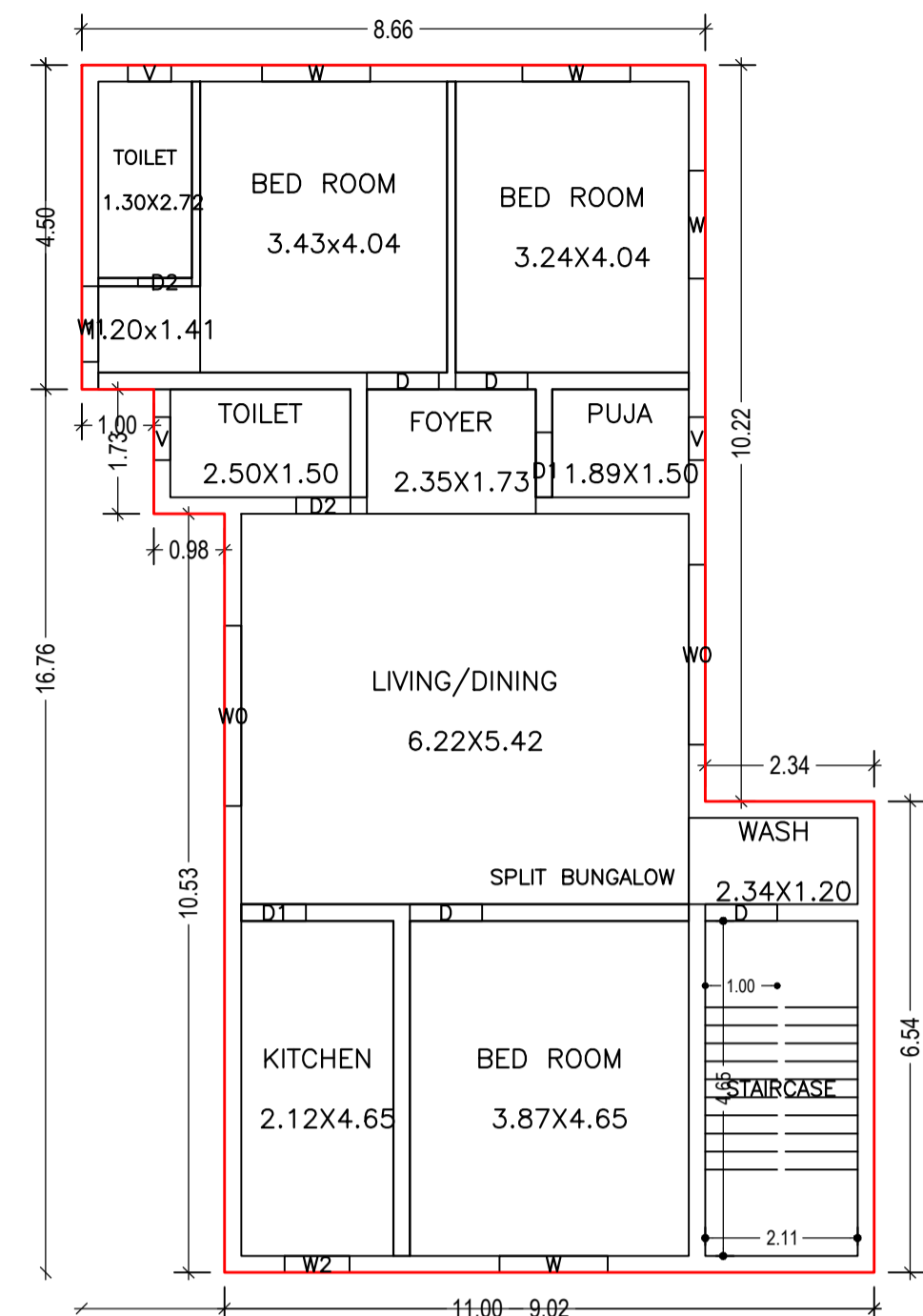

TERRACE FLOOR PLAN (SCALE 1:100)

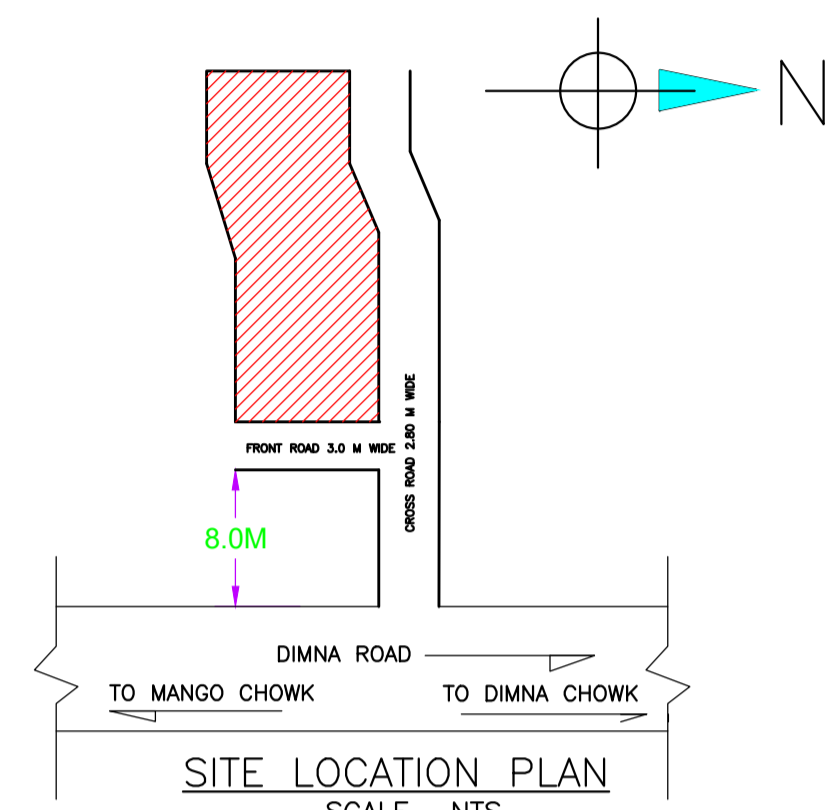
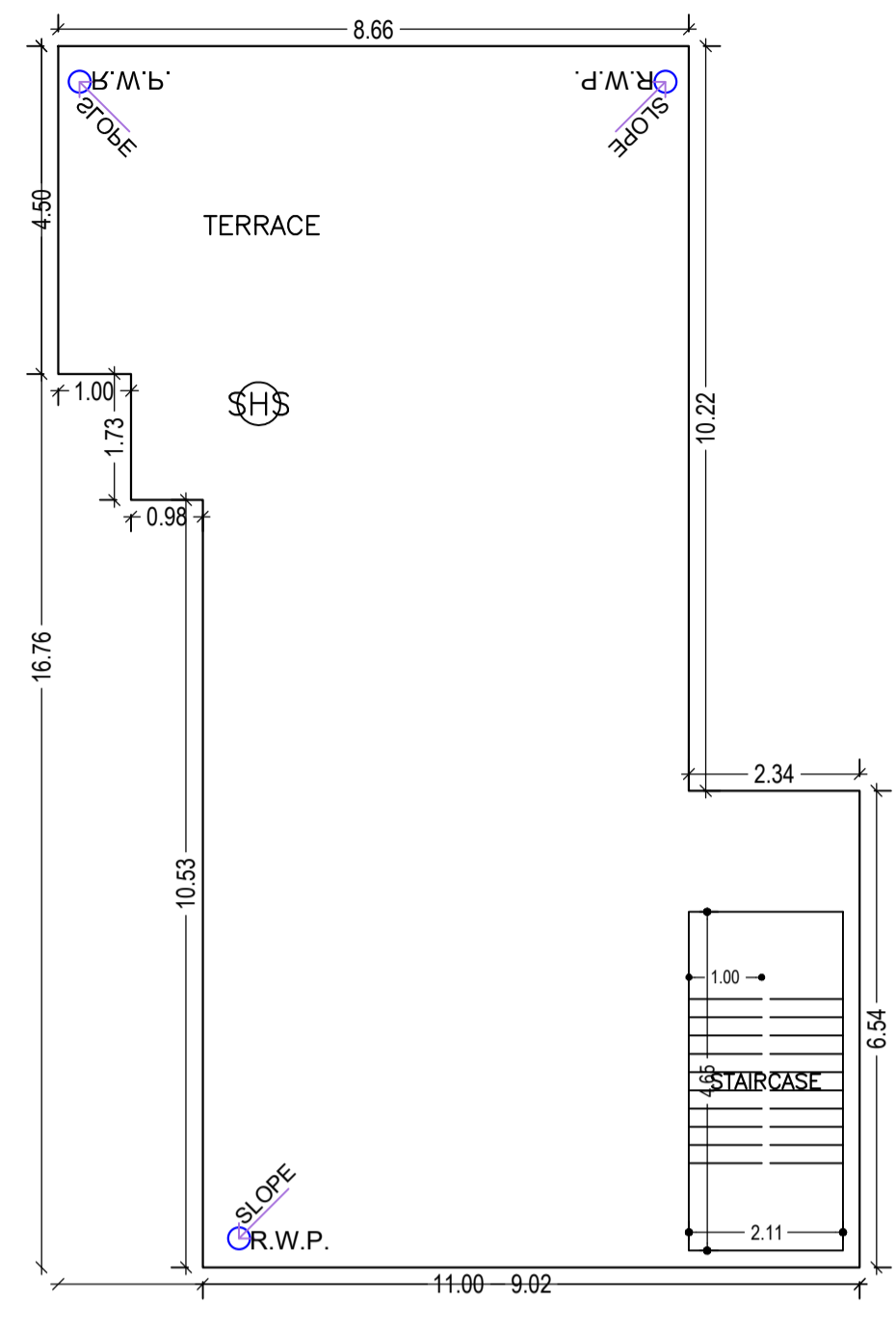

SITE LOCATION PLAN SCALE -NTS



FRONT ELEVATION SCALE 1:100

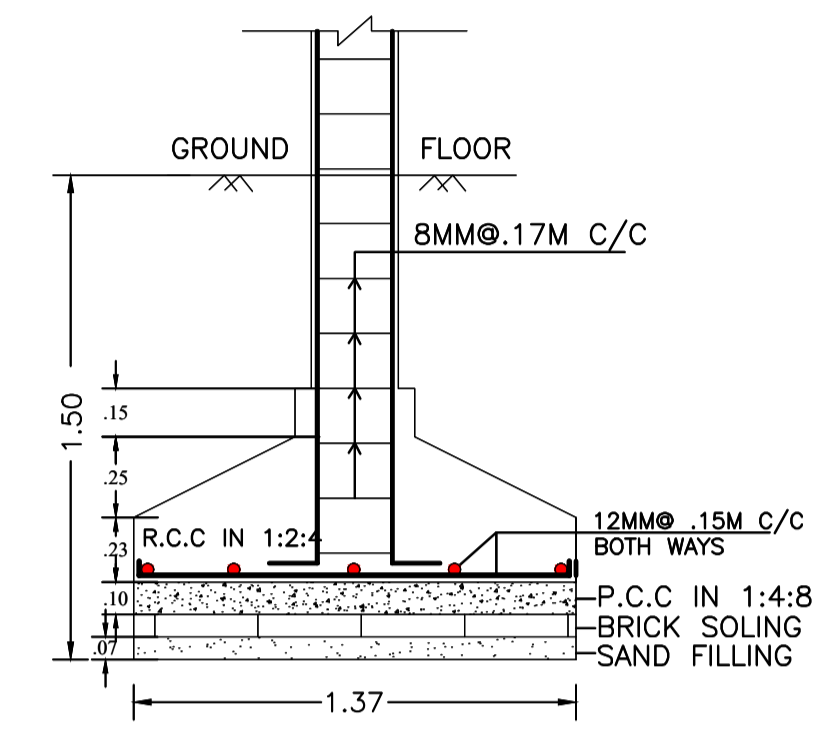

SECTION - CC SCALE -1:25

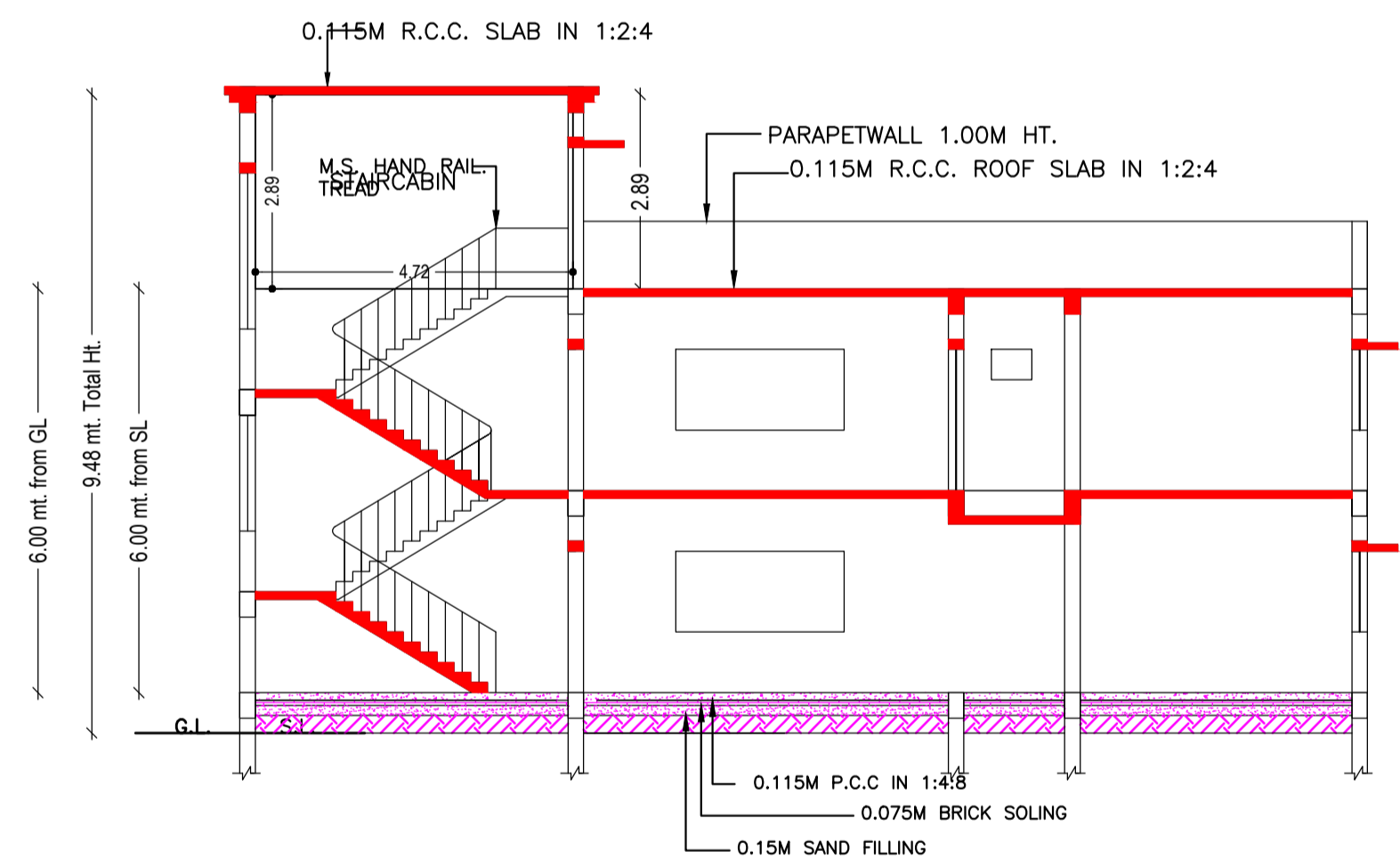

SECTION -A A SCALE 1:100

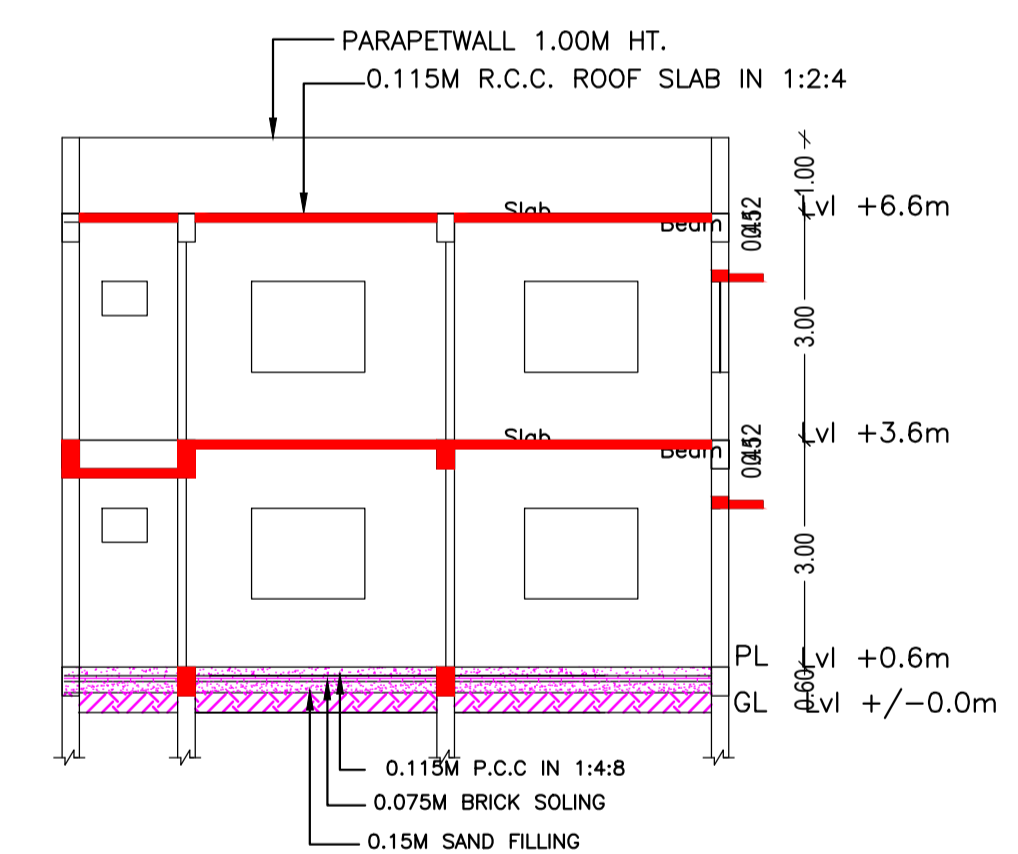

SECTION -B B SCALE 1:100

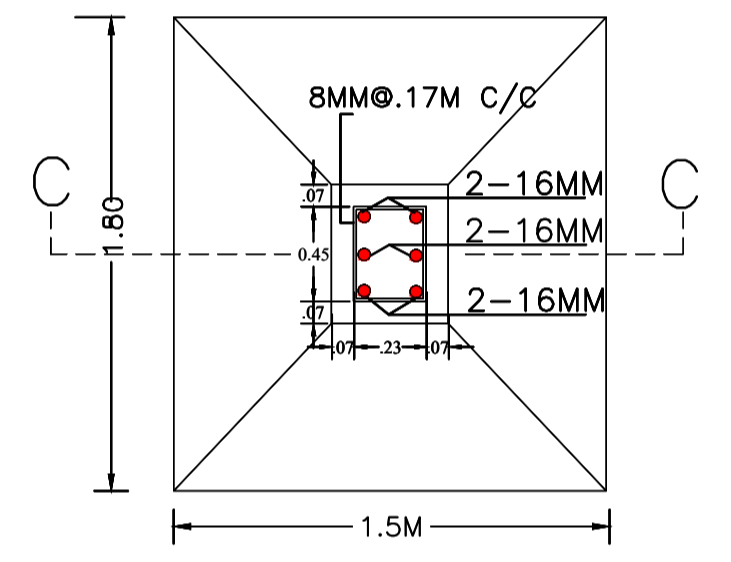

R.C.C. COL. FDN. PLAN SCALE -1:25

GROUND FLOOR PLAN (Proposed) (SCALE 1:100)

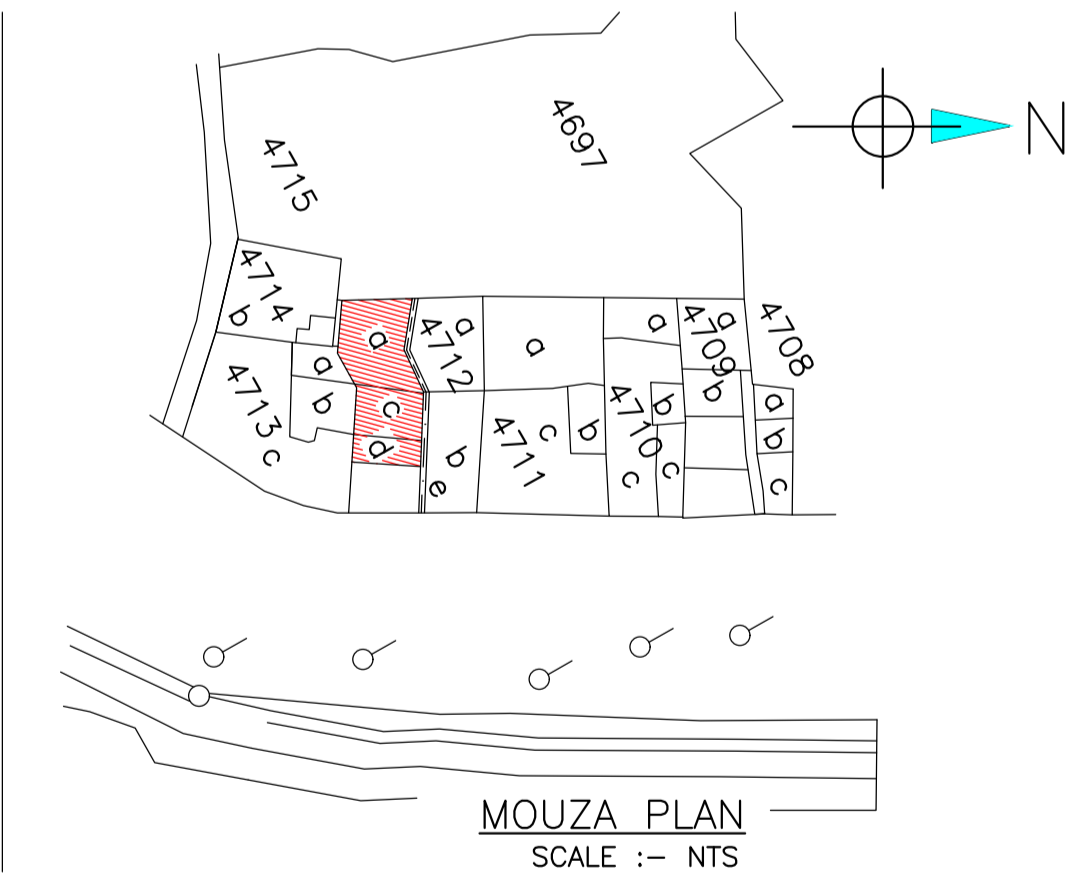

MOUZA PLAN SCALE :- NTS

Building :A (RESIDENTIAL)

Floor Name	Total Built Up Area (Sq.mt.)	Deductions (Area in Sq.mt.)		Proposed FAR Area (Sq.mt.)	Add Area In FAR (Sq.mt.)	Total FAR Area (Sq.mt.)	Total Consumed Additional FAR Area (Sq.mt.)	Trmt (No.)
		Parking	Resi.					
Ground Floor	137.84	75.79	52.22	9.83	62.05	62.05	01	
First Floor	137.84	0.00	137.84	0.00	137.84	137.84	00	
Terrace Floor	0.00	0.00	0.00	0.00	0.00	0.00	00	
Total :	275.68	75.79	190.06	9.83	199.89	199.89	01	
Total Number of Same Buildings	1							
Total :	275.68	75.79	190.06	9.83	199.89	199.89	01	

SCHEDULE OF DOOR:

BUILDING NAME	NAME	LENGTH	HEIGHT	NOS
A (RESIDENTIAL)	D2	0.75	2.10	04
A (RESIDENTIAL)	D1	0.90	2.10	03
A (RESIDENTIAL)	D	1.00	2.10	06

SCHEDULE OF WINDOW/VENTILATION:

BUILDING NAME	NAME	LENGTH	HEIGHT	NOS
A (RESIDENTIAL)	V	0.60	0.90	06
A (RESIDENTIAL)	W2	0.90	1.20	01
A (RESIDENTIAL)	W1	1.05	1.20	02
A (RESIDENTIAL)	W	1.50	1.20	07
A (RESIDENTIAL)	W0	2.50	1.20	02

UnitBUA Table for Building :A (RESIDENTIAL)

FLOOR	Name	UnitBUA Type	UnitBUA Area	Carpet Area	No. of Rooms	No. of Tenement
FIRST FLOOR PLAN	SPLIT BUNGALOW	FLAT	0.00	0.00	10	0
GROUND FLOOR PLAN	SPLIT BUNGALOW	FLAT	160.41	150.88	6	1
Total:	-	-	160.41	150.88	16	1

LTP NAME AND SIGNATURE	STRUCTURAL ENG'S NAME AND SIGNATURE	BUILDER NAME AND SIGNATURE	DIGITAL SIGNATURE
Chandrika Sharma MNAC/DFTMN/0017/2017			

Proposal Basic Information	
Proposal File No.	MNAC/BP/0082/W09/2023
Owner Name	MR. SHAMBHU PRASAD S O LATE AGNULAL KUMAR
Khata No	617
Plot No	4712
Village Name	Mango
Use	Residential
SubUse	Bungalow/ Dwelling / Non Apartment

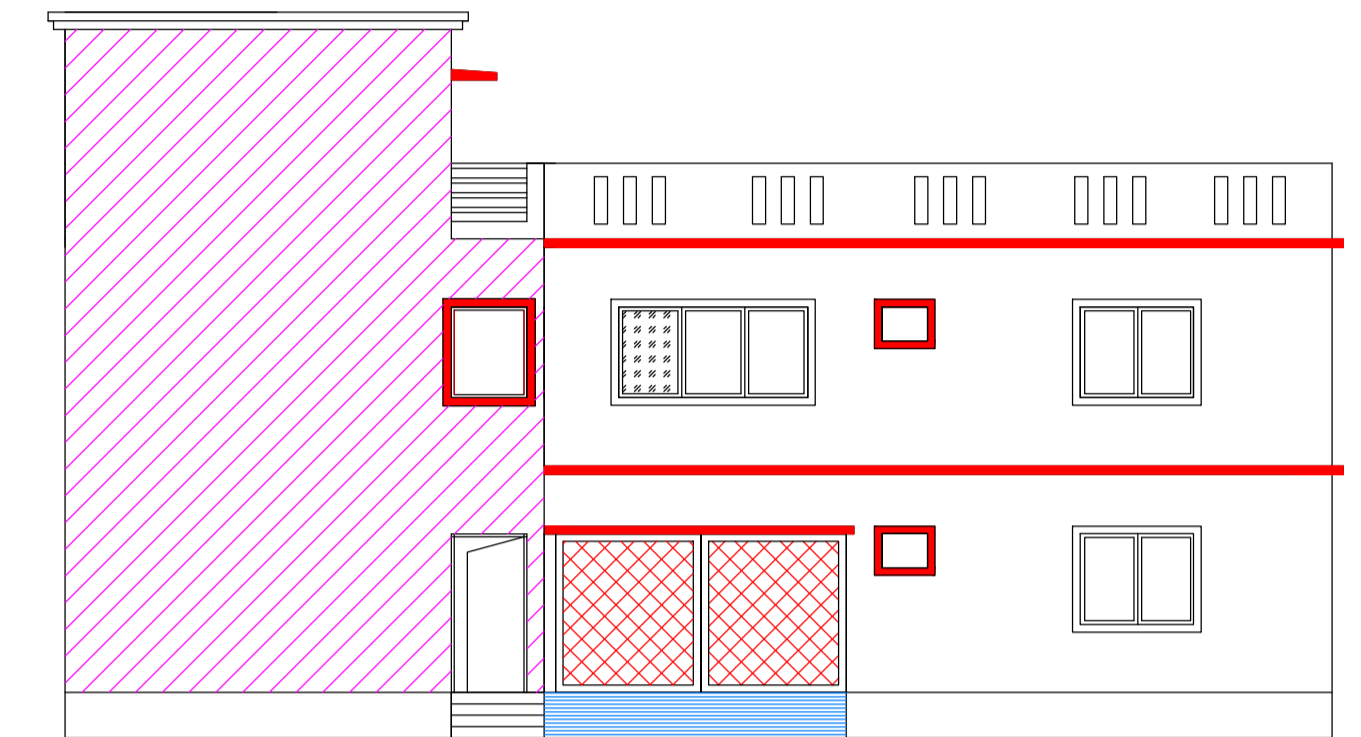

NORTH SIDE ELEVATION
SCALE 1:100

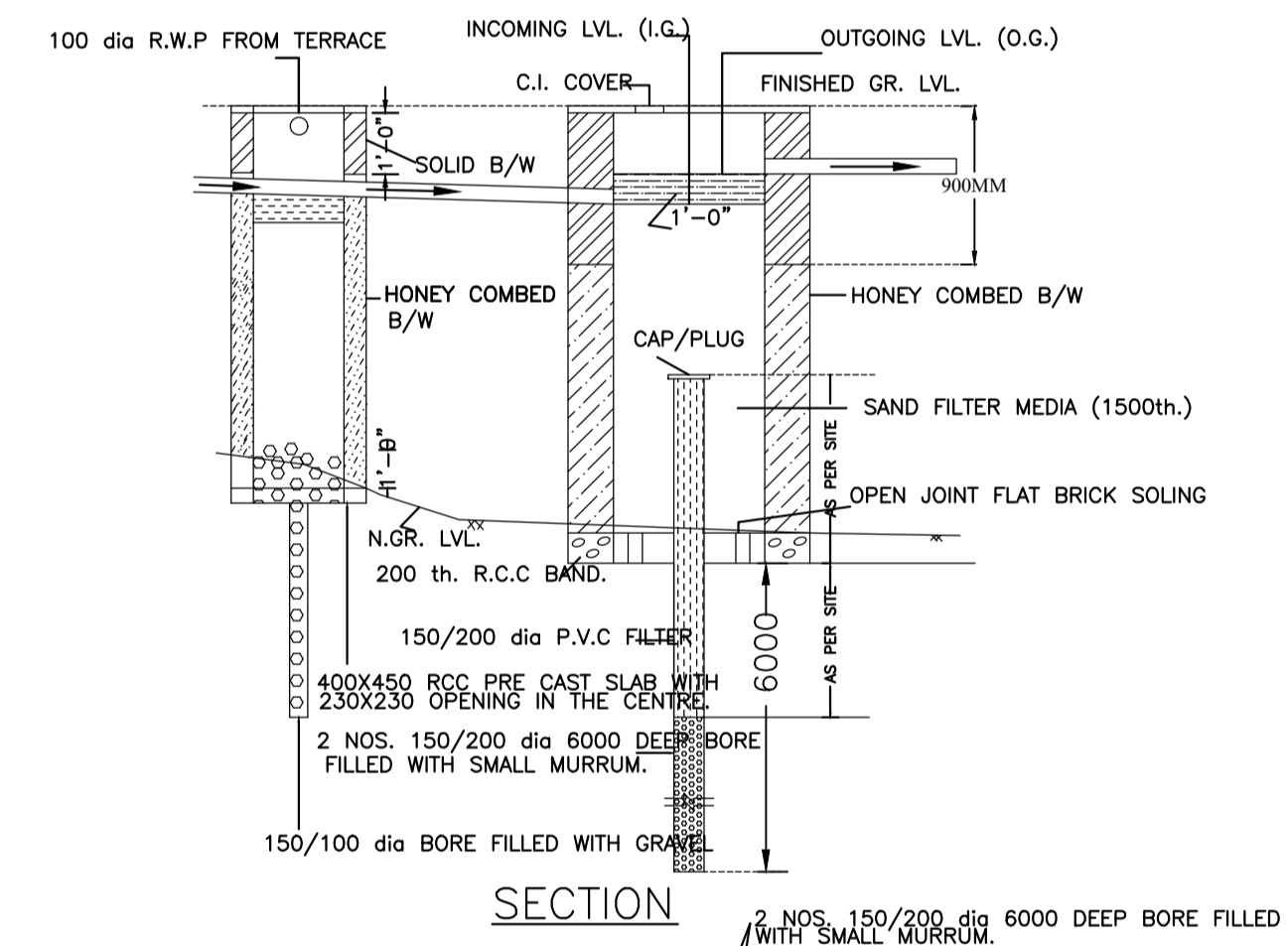

SECTION

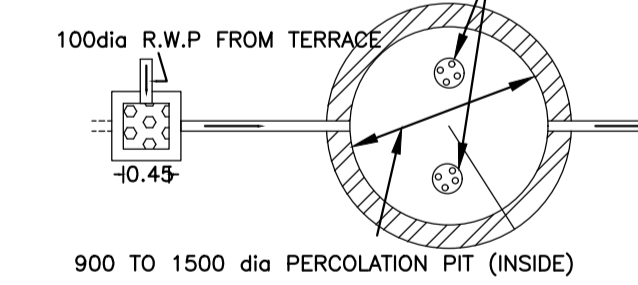

WATER HARVESTING PLAN (NTS)
SCALE - NTS

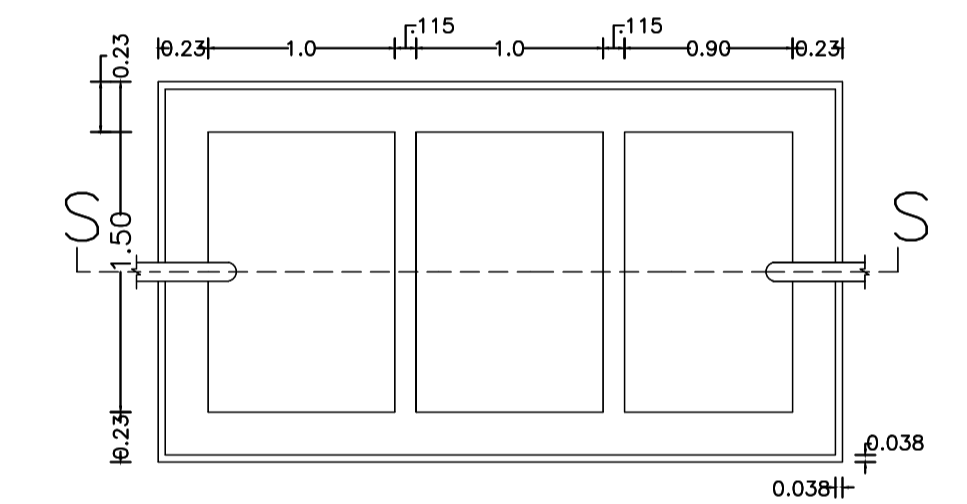

SEPTIC TANK PLAN

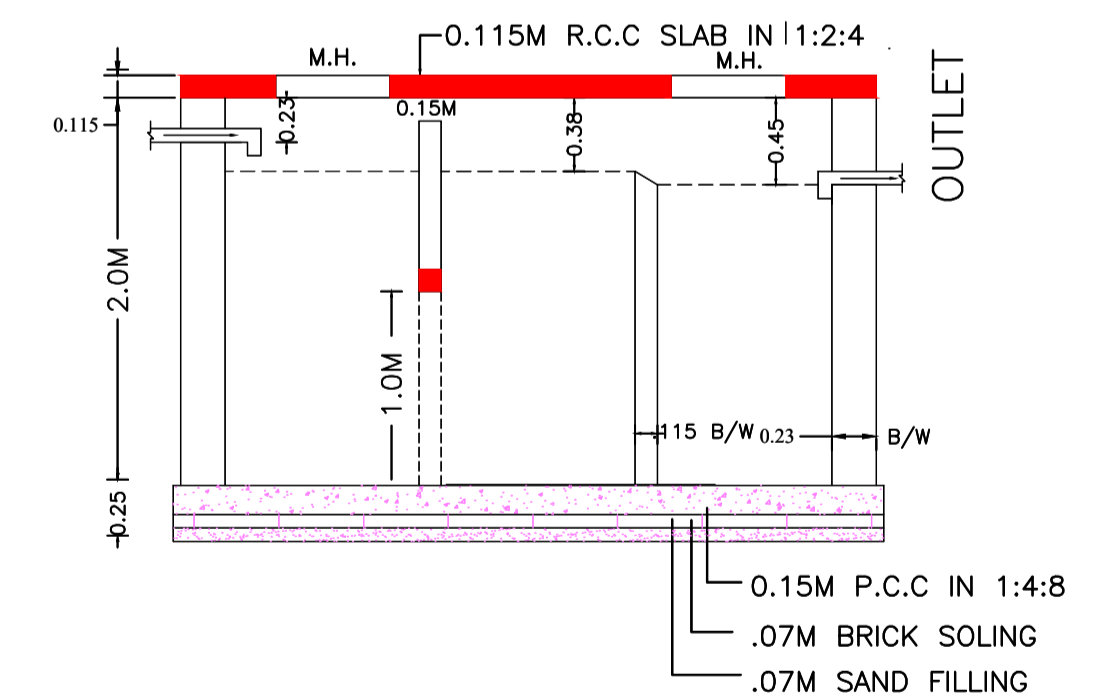

SECTION - SS
SCALE - 1:50

LTP NAME AND SIGNATURE	STRUCTURAL ENG'S NAME AND SIGNATURE	BUILDER NAME AND SIGNATURE	DIGITAL SIGNATURE
Chandrika Sharma MNAC/DFTMN/0017/2017			