

SITE - PLAN  
SCALE 1:100

SITE PLAN

FAR & Tenement Details (Table 4c-1)

Building	No. of Same Bldg	Total Built Up Area (Sq.mt.)	Deductions (Area in Sq.mt.)		Proposed FAR Area (Sq.mt.)	Add Area In FAR (Sq.mt.)	Total FAR Area (Sq.mt.)	Total Consumed Additional FAR Area (Sq.mt.)	Tenmt (No.)
			Parking	Resi.					
A (RESIDENTIAL)	1	170.88	51.21	110.62	110.62	9.05	119.67	119.67	01
<b>Grand Total :</b>	<b>1</b>	<b>170.88</b>	<b>51.21</b>	<b>110.62</b>	<b>110.62</b>	<b>9.05</b>	<b>119.67</b>	<b>119.67</b>	<b>01</b>

Proposal Basic Information

Proposal File No.	MNAC/BI/0033/W09/2024
Owner Name	MR. RAJEEV RANJAN
Khata No	501
Plot No	1895
Village Name	Mango
Use	Residential
SubUse	Bungalow/ Dwelling / Non Apartment

AREA STATEMENT MANGO MUNICIPAL CORPORATION	VERSION NO: 1.0.70	VERSION DATE: 16/10/2020
PROJECT DETAIL:		
Region: JHARKHAND URBAN LOCAL BODIES	Plot Use: Residential	
District: EAST SINGHBHUM	Plot SubUse: Bungalow/ Dwelling / Non Apartment	
Authority: MANGO MUNICIPAL CORPORATION	PlotNearbyReligiousStructure: NA	
Inward No: MNAC/BI/0033/W09/2024	PlotSubPlot No: 1895	
Application Type: General Proposal	North: -	
Project Type: Building Permission	South: -	
Nature of Development: New	East: -	
Location of Development Area: Old Area	West: -	
AREA DETAILS:		
AREA OF PLOT (Minimum)	(A)	133.08
NET AREA OF PLOT(Gross Plot Area - Deduction from Gross Plot area)	(A-Deductions)	133.08
Deduction for Balance Plot Area(from Gross Plot Area)		
Common Plot		14.55
Total		14.55
BALANCE AREA OF PLOT(Net Plot Area - Recreational/Amenity space)	(A-Deductions)	118.53
PLOT AREA FOR COVERAGE(Net Plot Area)	(A-Deductions)	133.08
Plot Area for FAR (Net Plot Area + RoadWidening Area)	(A-Deductions)	133.08
COVERAGE CHECK		
Permissible Coverage area ( 70.00 % )		93.16
Proposed Coverage Area ( 64.20 % )		85.44
Total Prop. Coverage Area ( 64.2 % )		85.44
Balance coverage area ( 5.80 % )		7.72
FAR CHECK		
Perm. FAR Area ( 1.500 )		199.62
Total Perm. FAR area		199.62
Residential FAR		110.62
Proposed FAR Area		119.67
Total Proposed FAR Area		119.67
Consumed FAR (Factor)		0.90
Balance FAR Area		79.95
BUILT UP AREA CHECK		
Total Proposed BuiltUp Area		170.88
ARCHITECT (Regd)	EJAZ AHMAD	
ENGINEER (Regd)		
SUPERVISOR (Regd)		
OWNER (Regd)	MR. RAJEEV RANJAN	
DEVELOPMENT AUTHORITY		LOCAL BODY

COLOR INDEX	
PLOT BOUNDARY	Black
ABUTTING ROAD	Green
PROPOSED CONSTRUCTION	Red
COMMON PLOT	Yellow
ROAD WIDENING AREA	Light Blue
EXISTING (To be retained)	Blue
EXISTING (To be demolished)	Orange

Buildingwise Floor FAR Details

Floor Name	Building Name A (RESIDENTIAL)		Total	
	Proposed Built Up Area (Sq.mt.)	Proposed FAR Area (Sq.mt.)	Total Proposed Built Up Area (Sq.mt.)	Total FAR Area (Sq.mt.)
Ground Floor	85.44	34.23	85.44	34.23
First Floor	85.44	85.44	85.44	85.44
Terrace Floor	0.00	0.00	0.00	0.00
<b>Total :</b>	<b>170.88</b>	<b>119.67</b>	<b>170.88</b>	<b>119.67</b>

Building USE/SUBUSE Details

Building Name	Building Use	Building SubUse	Building Structure
A (RESIDENTIAL)	Residential	Bungalow/ Dwelling / Non Apartment	Non-Highrise

LTP NAME AND SIGNATURE	STRUCTURAL ENG'S NAME AND SIGNATURE	BUILDER NAME AND SIGNATURE	DIGITAL SIGNATURE
EJAZ AHMAD MNAC/DFTMN/0008/2020			

Proposal Basic Information	
Proposal File No.	MNAC/BI/0033/W09/2024
Owner Name	MR. RAJEEV RANJAN
Khata No	501
Plot No	1895
Village Name	Mango
Use	Residential
SubUse	Bungalow/ Dwelling / Non Apartment

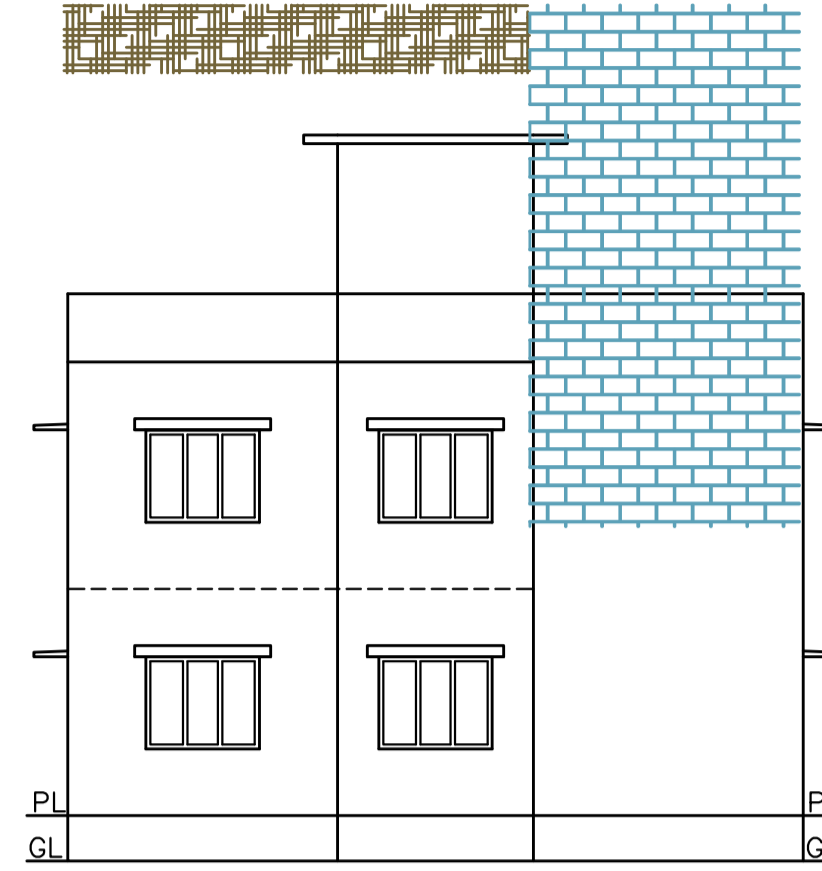
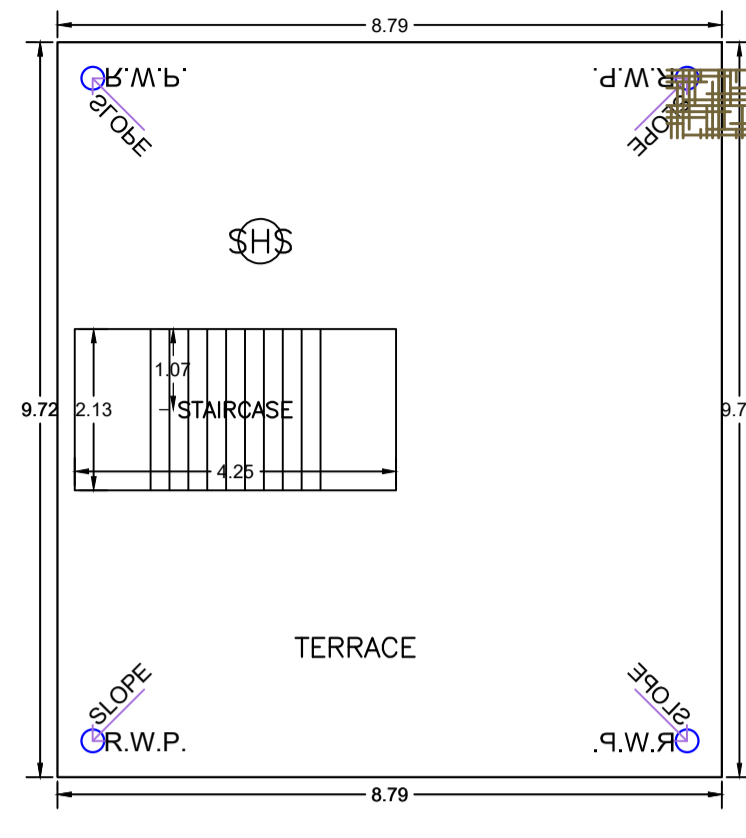
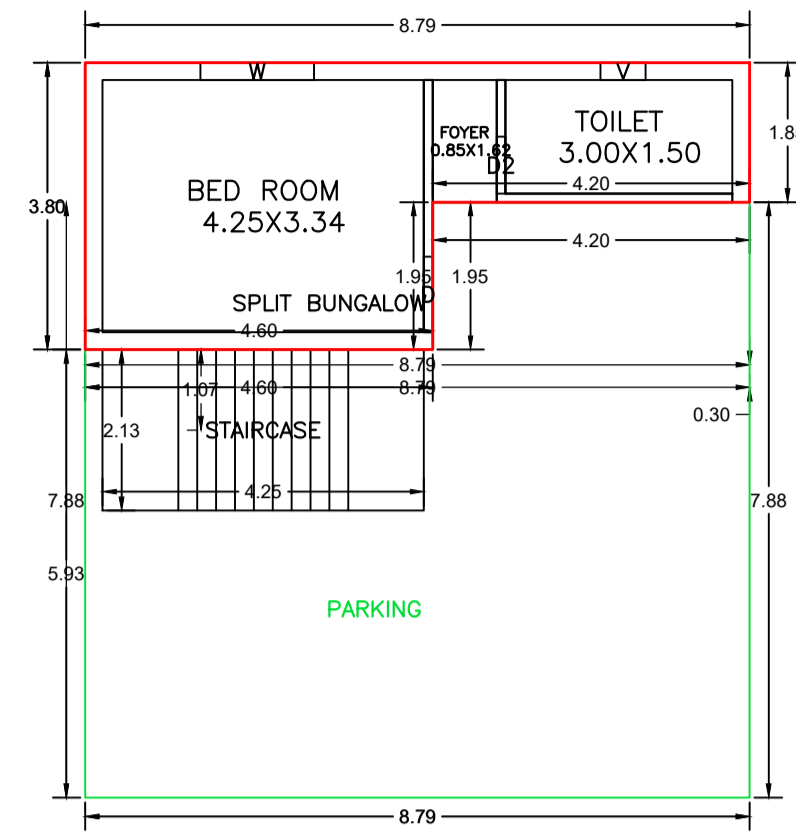

NORTH SIDE ELEVATION  
SCALE 1:100

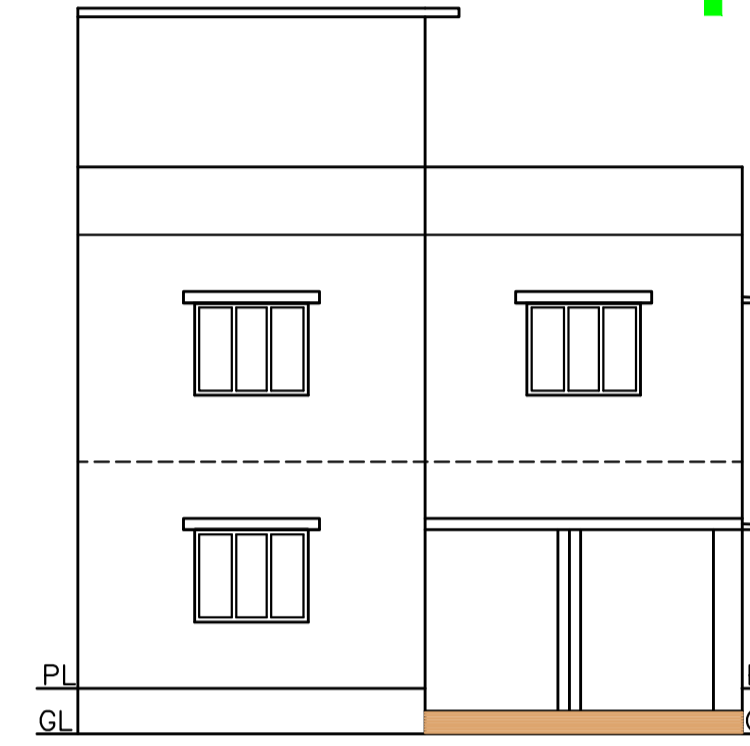

FRONT ELEVATION  
SCALE 1:100

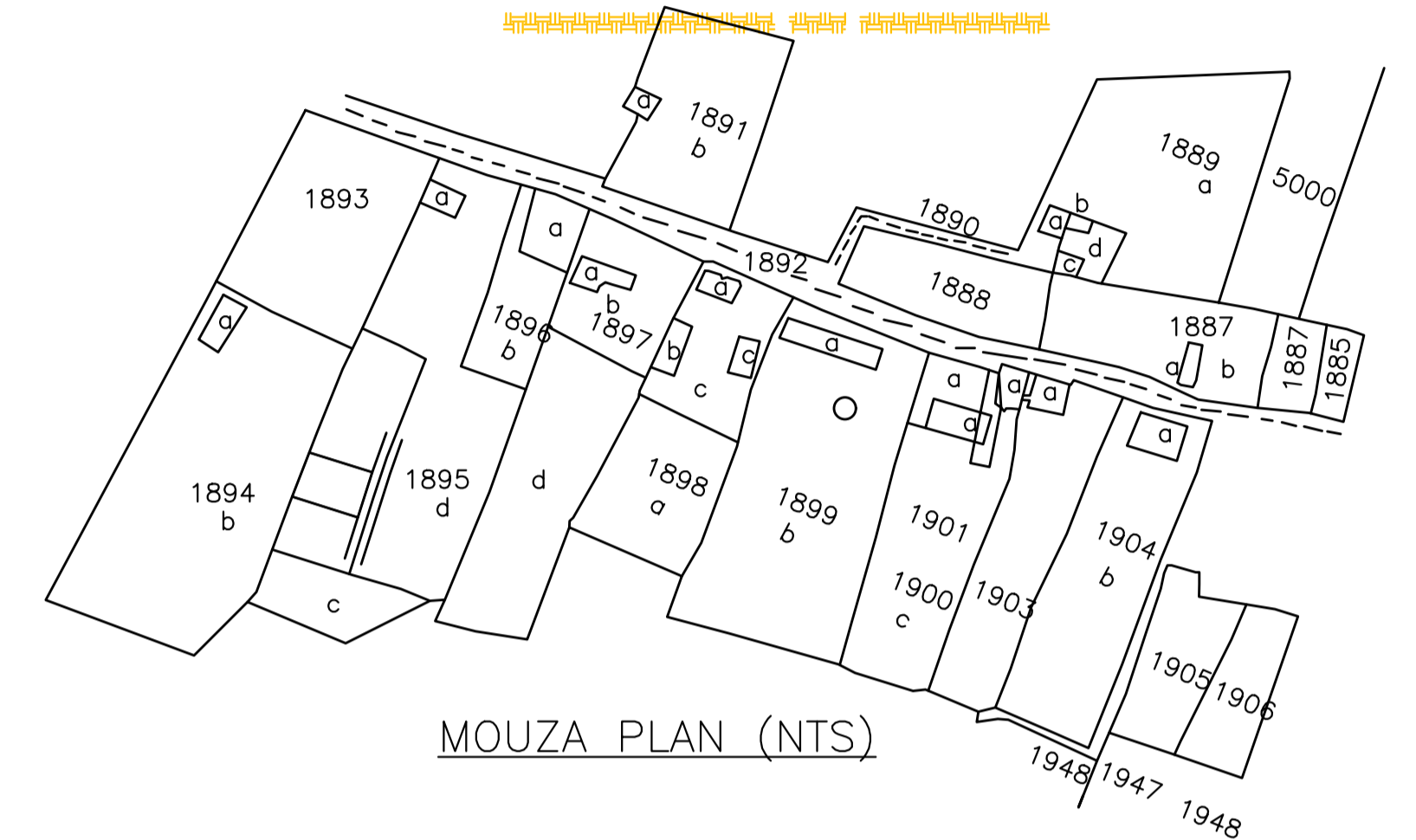

MOUZA PLAN (NTS)

GROUND FLOOR PLAN (Proposed) (SCALE 1:100)

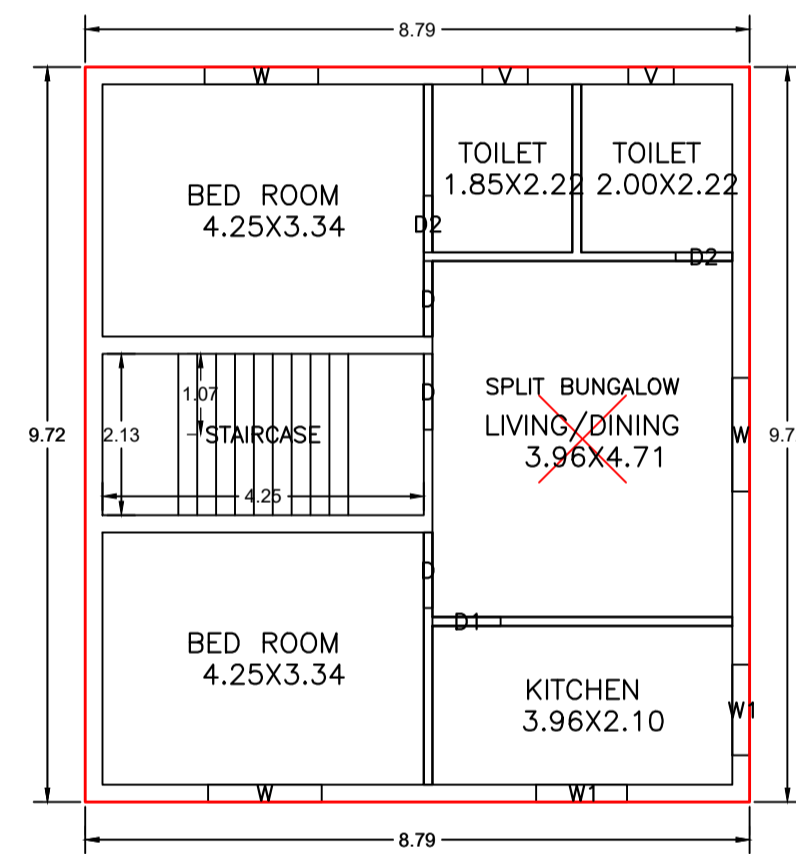

FIRST FLOOR PLAN (Proposed) (SCALE 1:100)

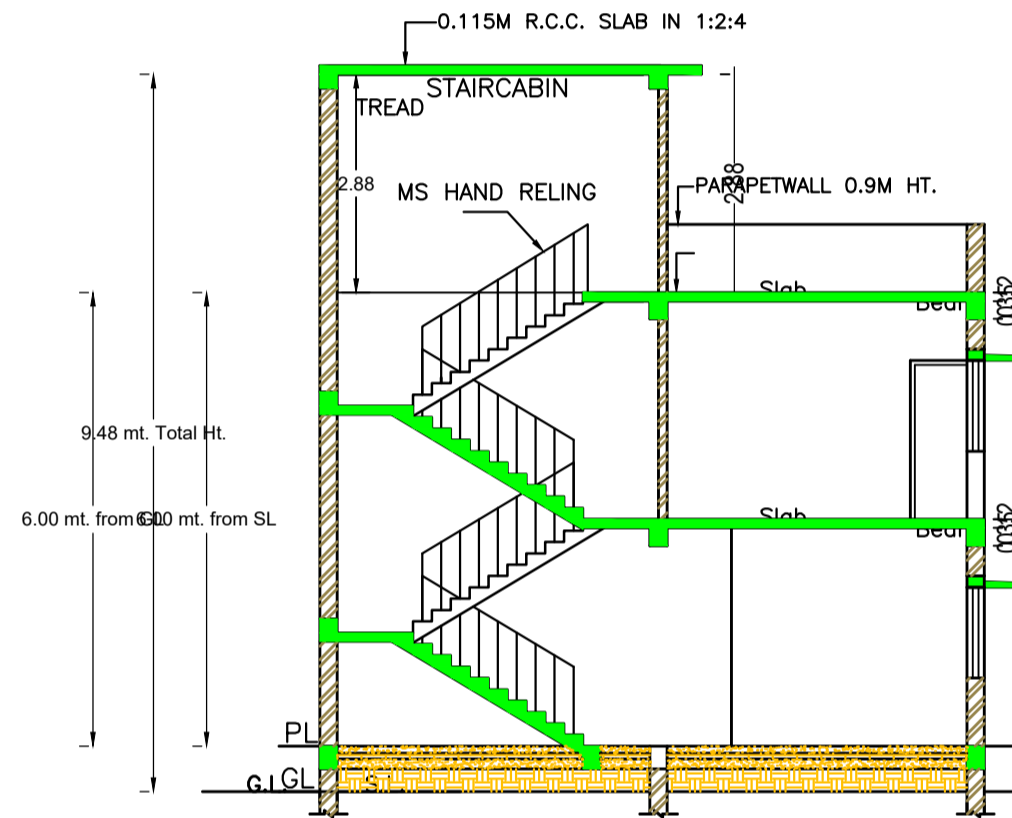

SECTION - AA  
SCALE 1:100

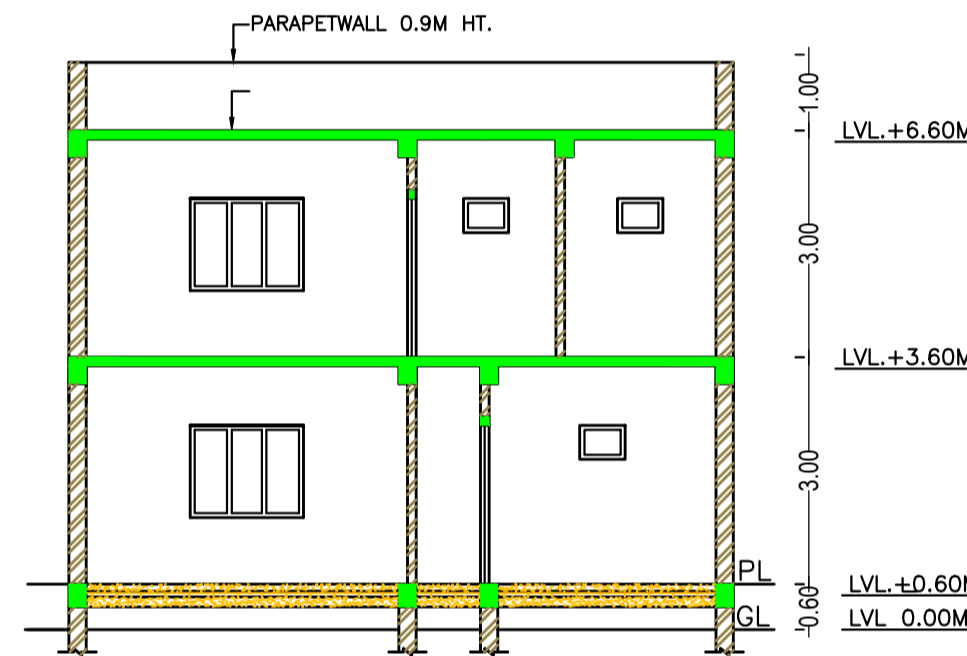

SECTION - BB  
SCALE 1:100

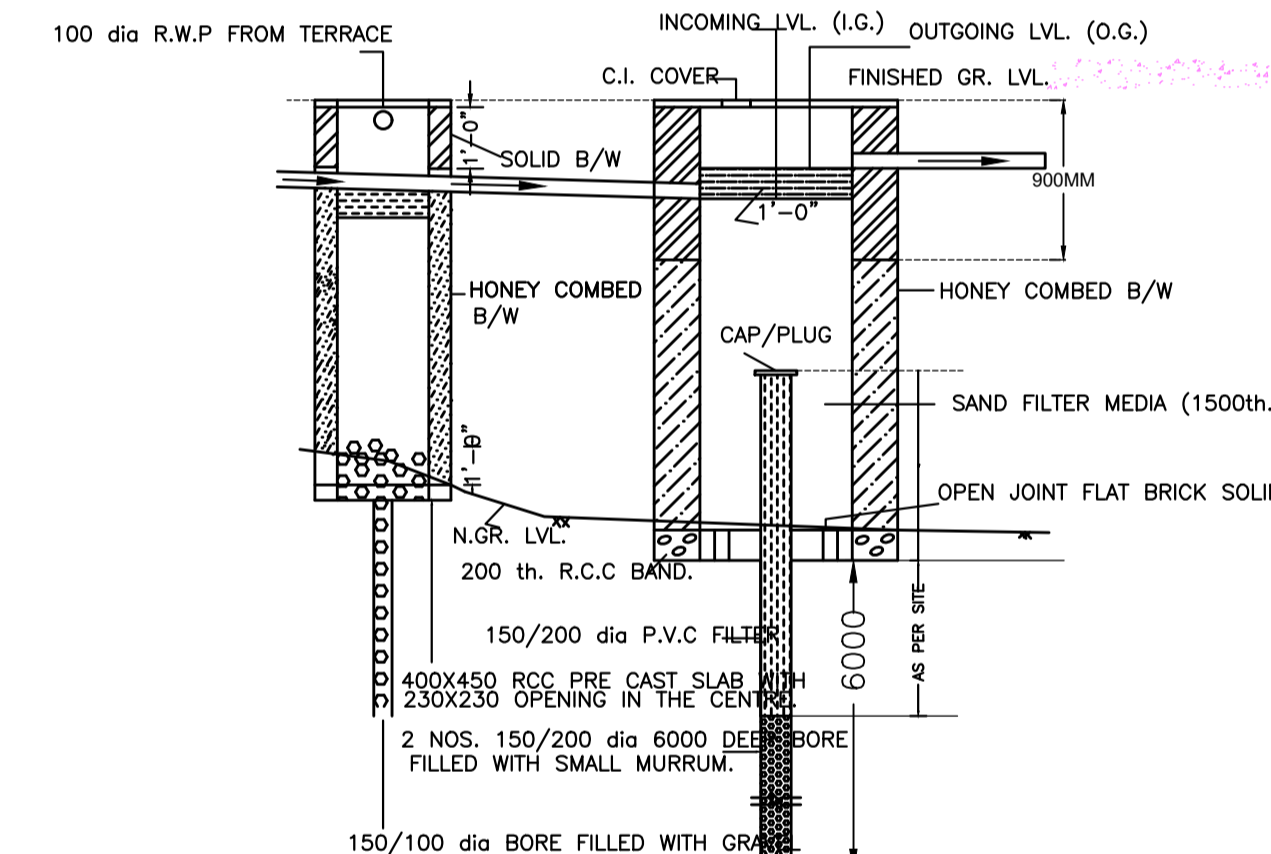

SECTION

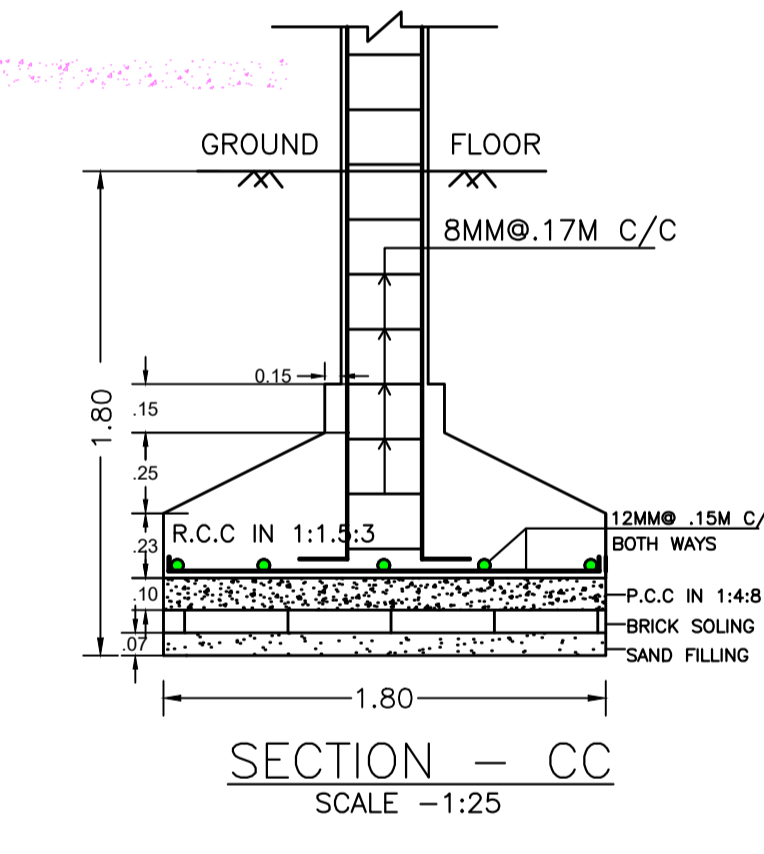

SECTION - CC  
SCALE -1:25

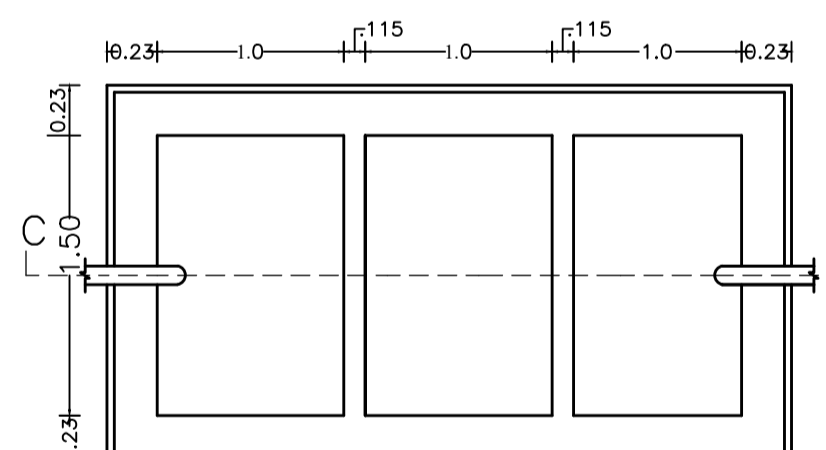

SEPTIC TANK PLAN  
SCALE -1:50

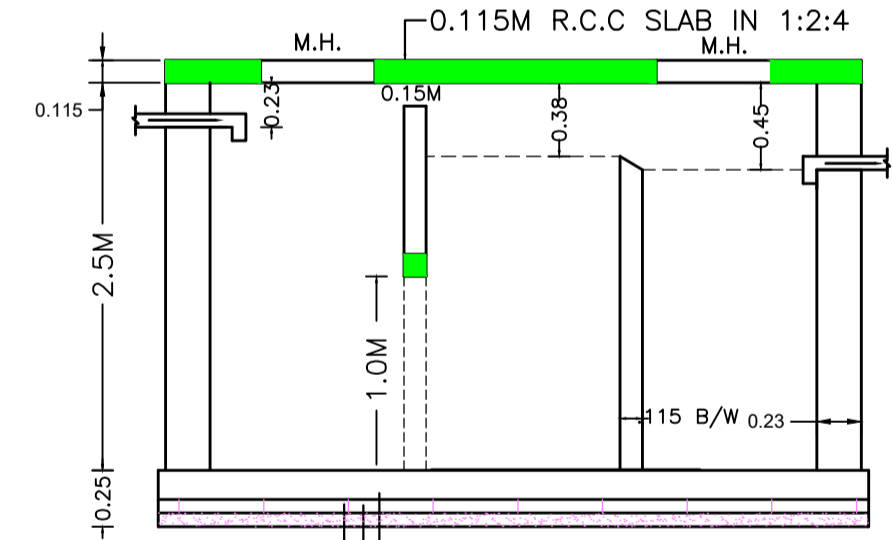

SECTION - SS  
SCALE -1:50

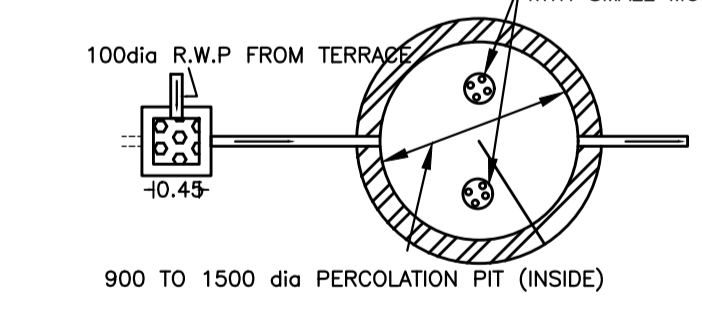

WATER HARVESTING PLAN (NTS)

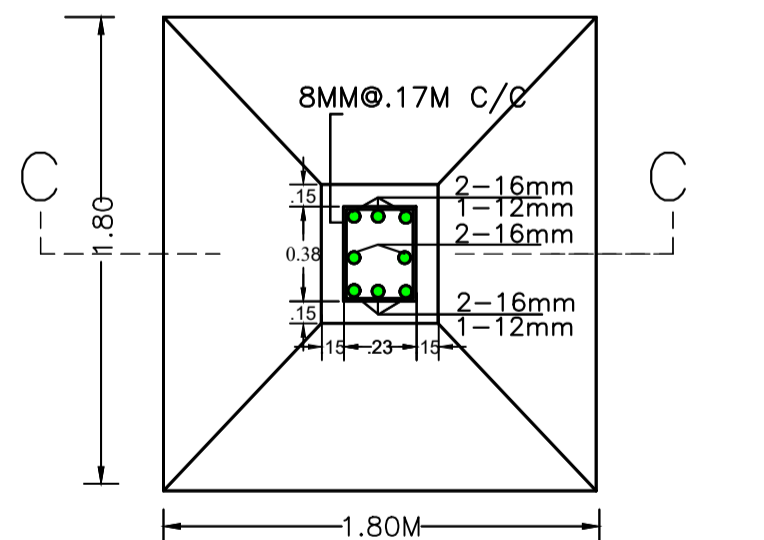

R.C.C. COL. FDN. PLAN  
SCALE -1:25

Building :A (RESIDENTIAL)

Floor Name	Total Built Up Area (Sq.mt.)	Deductions (Area in Sq.mt.)		Proposed FAR Area (Sq.mt.)	Add Area In FAR (Sq.mt.)	Total FAR Area (Sq.mt.)	Total Consumed Additional FAR Area (Sq.mt.)	Trmt (No.)
		Parking	Resi.					
Ground Floor	85.44	51.21	25.18	9.05	34.23	34.23	01	
First Floor	85.44	0.00	85.44	0.00	85.44	85.44	00	
Terrace Floor	0.00	0.00	0.00	0.00	0.00	0.00	00	
Total :	170.88	51.21	110.62	9.05	119.67	119.67	01	
Total Number of Same Buildings	1							
Total :	170.88	51.21	110.62	9.05	119.67	119.67	01	

SCHEDULE OF DOOR:

BUILDING NAME	NAME	LENGTH	HEIGHT	NOS
A (RESIDENTIAL)	D2	0.75	2.10	03
A (RESIDENTIAL)	D1	0.90	2.10	01
A (RESIDENTIAL)	D	1.00	2.10	04

SCHEDULE OF WINDOW/VENTILATION:

BUILDING NAME	NAME	LENGTH	HEIGHT	NOS
A (RESIDENTIAL)	V	0.60	0.90	03
A (RESIDENTIAL)	W1	1.20	1.20	02
A (RESIDENTIAL)	W	1.50	1.20	04

UnitBUA Table for Building :A (RESIDENTIAL)

FLOOR	Name	UnitBUA Type	UnitBUA Area	Carpet Area	No. of Rooms	No. of Tenement
GROUND FLOOR PLAN	SPLIT BUNGALOW	FLAT	86.79	83.94	3	1
FIRST FLOOR PLAN	SPLIT BUNGALOW	FLAT	0.00	0.00	6	0
Total:	-	-	86.79	83.94	9	1

LTP NAME AND SIGNATURE	STRUCTURAL ENG'S NAME AND SIGNATURE	BUILDER NAME AND SIGNATURE	DIGITAL SIGNATURE
EJAZ AHMAD MNAC/DFTMN/0008/2020			