

SITE PLAN

FAR & Tenement Details (Table 4c-1)

Building	No. of Same Bldg	Total Built Up Area (Sq.mt.)	Deductions (Area in Sq.mt.)		Proposed FAR Area (Sq.mt.)	Add Area In FAR (Sq.mt.)	Total FAR Area (Sq.mt.)	Total Consumed Additional FAR Area (Sq.mt.)	Tnmt (No.)
			Parking	Resi.					
A (RESIDENTIAL)	1	121.54	32.79	79.31	9.44	88.75	88.75	01	
Grand Total :	1	121.54	32.79	79.31	9.44	88.75	88.75	01	

Proposal Basic Information

Proposal File No.	MNAC/BP/0036/W09/2024
Owner Name	MR. YASH JAISWAL
Khata No	481
Plot No	461
Village Name	Pardih
Use	Residential
SubUse	Bungalow/ Dwelling / Non Apartment

AREA STATEMENT MANGO MUNICIPAL CORPORATION		VERSION NO.: 1.0.70
		VERSION DATE: 16/10/2020
PROJECT DETAIL:		
Region: JHARKHAND URBAN LOCAL BODIES	Plot Use: Residential	
District: EAST SINGHBHUM	Plot SubUse: Bungalow/ Dwelling / Non Apartment	
Authority: MANGO MUNICIPAL CORPORATION	PlotNearbyReligiousStructure: NA	
Inward No: MNAC/BP/0036/W09/2024	PlotSubPlot No: 461	
Application Type: General Proposal	North: Road Width - 4.90	
Project Type: Building Permission	South: Plot No. - 461	
Nature of Development: New	East: Plot No. - 459	
Location of Development Area: Old Area	West: Road Width - 4.90	
AREA DETAILS:		
AREA OF PLOT (Minimum)	(A)	SQ.MT. 167.13
NET AREA OF PLOT(Gross Plot Area - Deduction from Gross Plot area)	(A-Deductions)	167.13
Deduction for Balance Plot Area(from Gross Plot Area)		
Common Plot		19.46
Total		19.46
BALANCE AREA OF PLOT(Net Plot Area - Recreational/Amenity space)	(A-Deductions)	147.67
PLOT AREA FOR COVERAGE(Net Plot Area)	(A-Deductions)	167.13
Plot Area for FAR (Net Plot Area + Road Widening Area)	(A-Deductions)	167.13
COVERAGE CHECK		
Permissible Coverage area (70.00 %)		116.99
Proposed Coverage Area (36.36 %)		60.77
Total Prop. Coverage Area (36.36 %)		60.77
Balance coverage area (33.64 %)		56.22
FAR CHECK		
Perm. FAR Area (1.800)		300.83
Total Perm. FAR area		300.83
Residential FAR		79.30
Proposed FAR Area		88.74
Total Proposed FAR Area		88.74
Consumed FAR (Factor)		0.53
Balance FAR Area		212.09
BUILT UP AREA CHECK		
Total Proposed BuiltUp Area		121.54
ARCHITECT (Regd)	Chandrika Sharma	
ENGINEER (Regd)		
SUPERVISOR (Regd)		
OWNER (Regd)	MR. YASH JAISWAL	
DEVELOPMENT AUTHORITY		LOCAL BODY

COLOR INDEX	
PLOT BOUNDARY	Black
ABUTTING ROAD	Green
PROPOSED CONSTRUCTION	Red
COMMON PLOT	Yellow
ROAD WIDENING AREA	Orange
EXISTING (To be retained)	Blue
EXISTING (To be demolished)	Light Blue

Buildingwise Floor FAR Details

Floor Name	Building Name A (RESIDENTIAL)		Total	
	Proposed Built Up Area (Sq.mt.)	Proposed FAR Area (Sq.mt.)	Total Proposed Built Up Area (Sq.mt.)	Total FAR Area (Sq.mt.)
Ground Floor	60.77	27.98	60.77	27.98
First Floor	60.77	60.77	60.77	60.77
Terrace Floor	0.00	0.00	0.00	0.00
Total :	121.54	88.75	121.54	88.75

Building USE/SUBUSE Details

Building Name	Building Use	Building SubUse	Building Structure
A (RESIDENTIAL)	Residential	Bungalow/ Dwelling / Non Apartment	Non-Highrise

LTP NAME AND SIGNATURE	STRUCTURAL ENG'S NAME AND SIGNATURE	BUILDER NAME AND SIGNATURE	DIGITAL SIGNATURE
Chandrika Sharma MNAC/DFTMN/0017/2017			

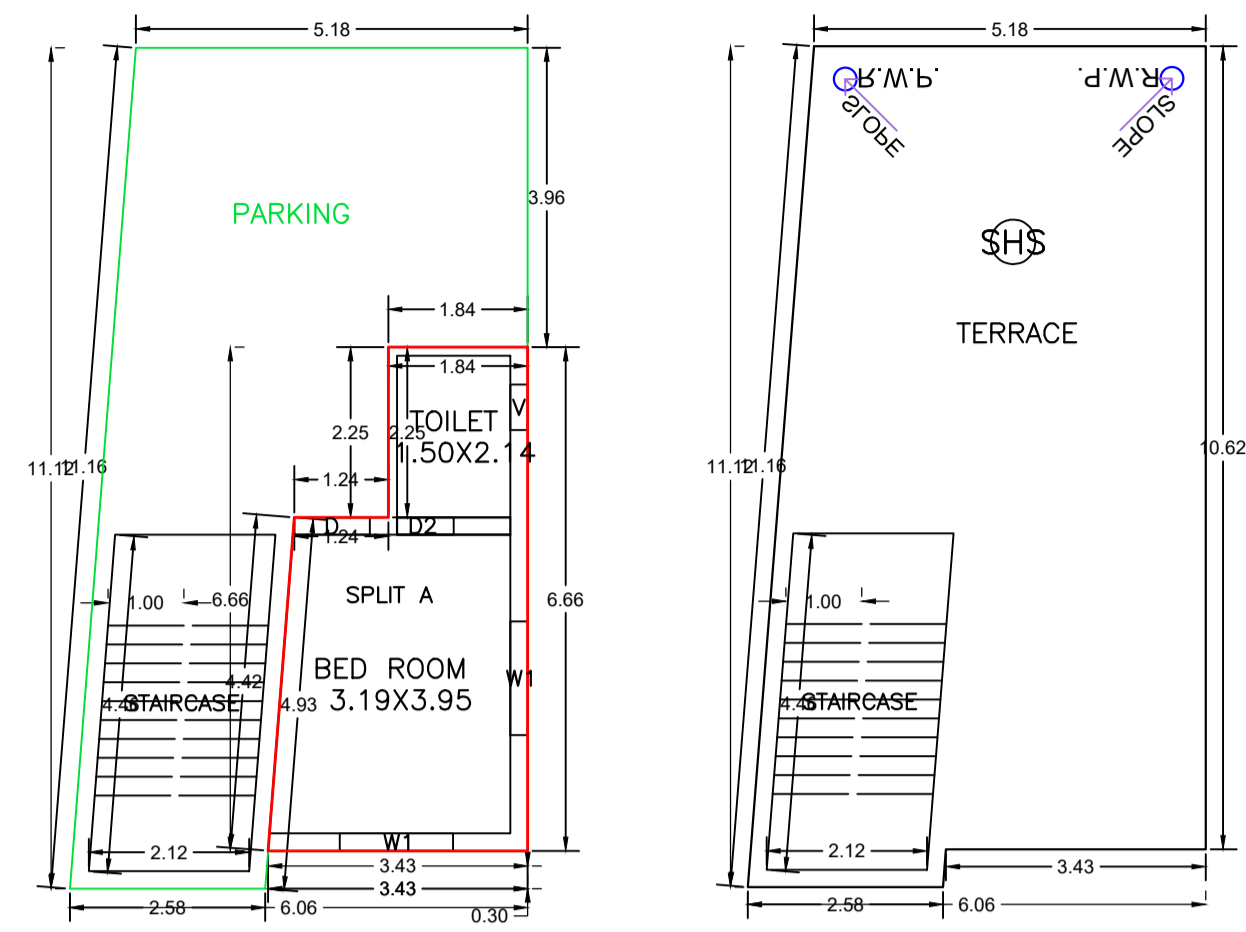

TERRACE FLOOR PLAN (SCALE 1:100)

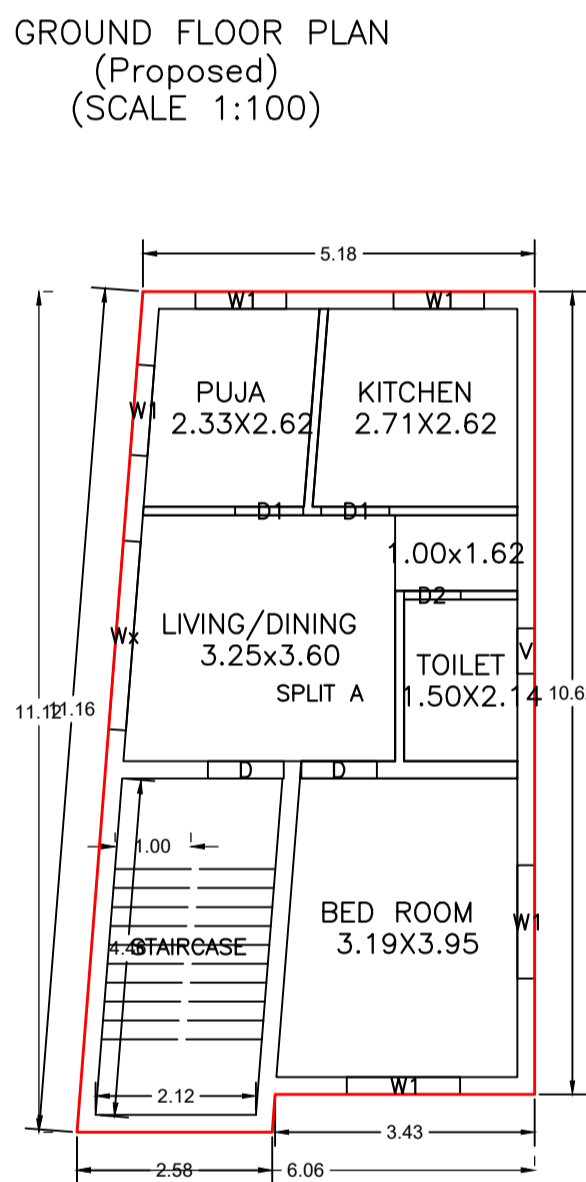

FIRST FLOOR PLAN (Proposed) (SCALE 1:100)

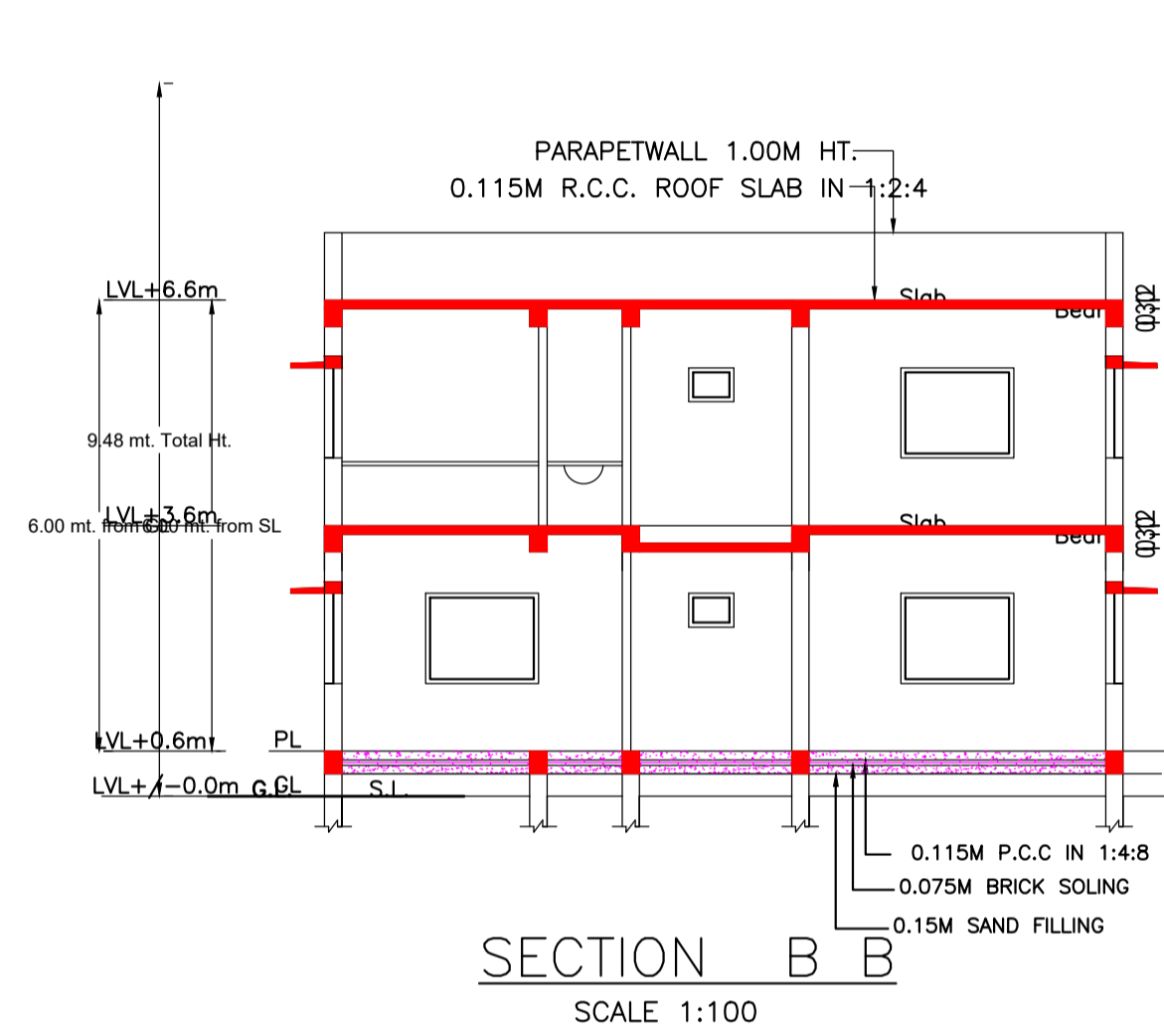

SECTION B B (SCALE 1:100)

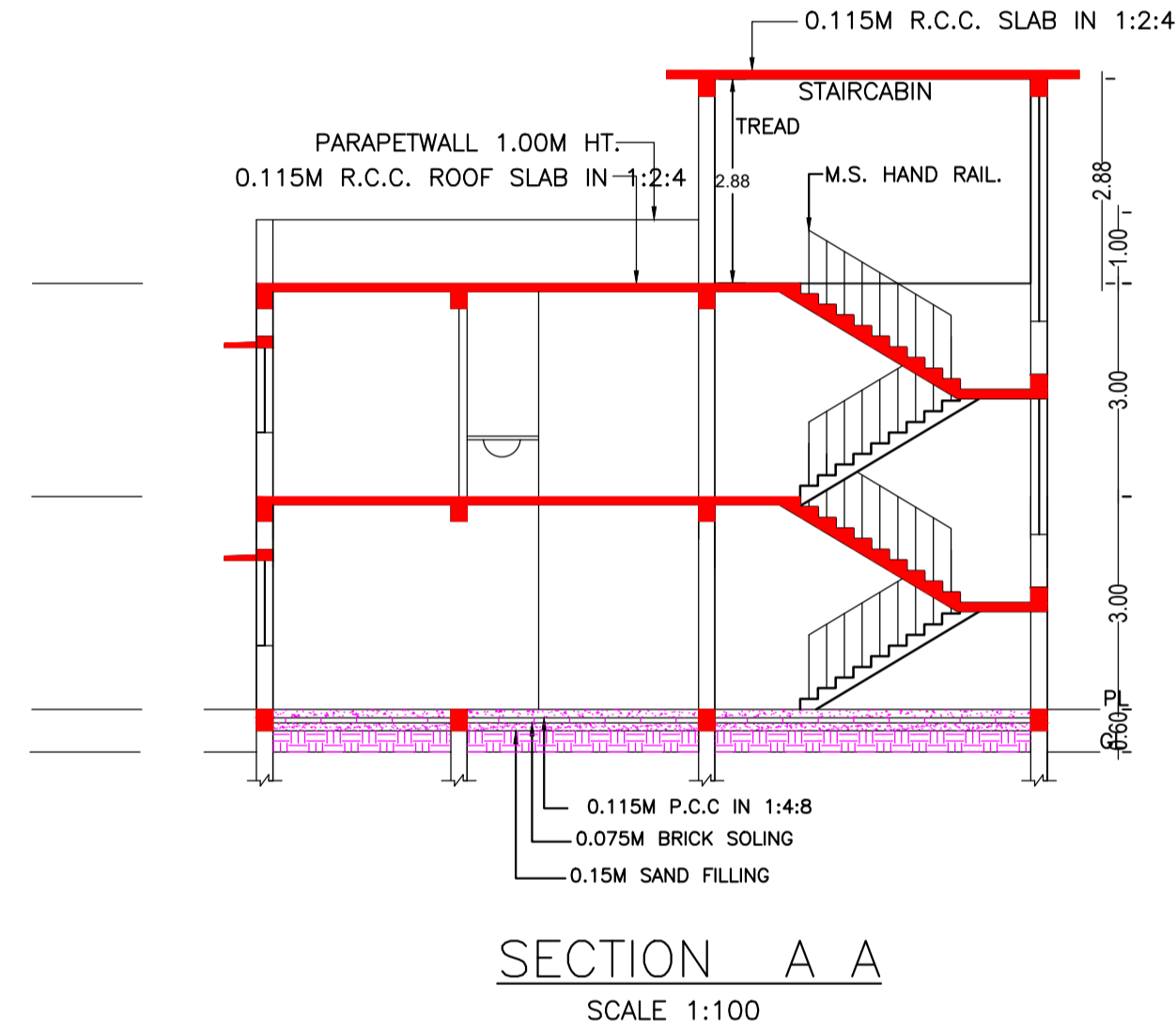

SECTION A A (SCALE 1:100)

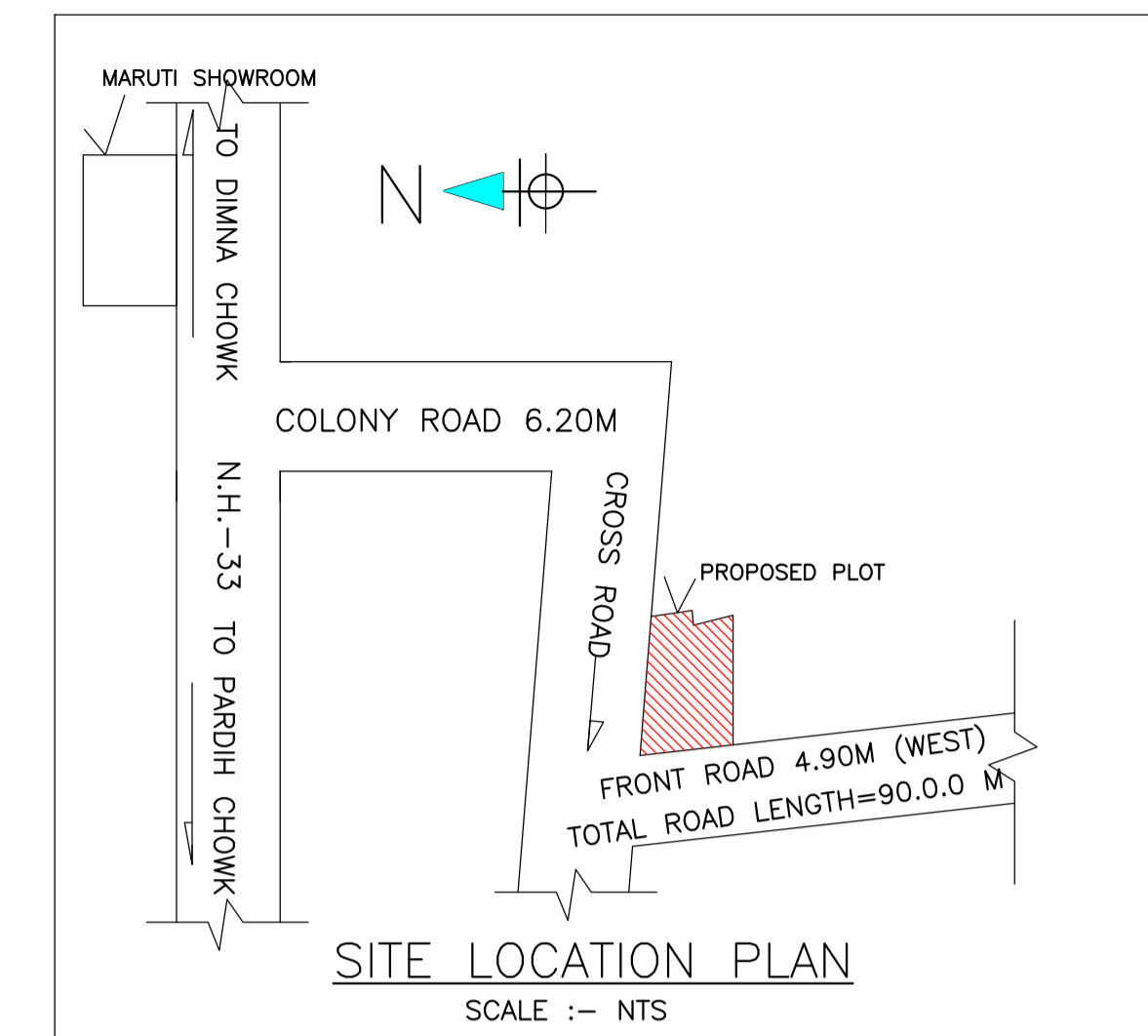

SITE LOCATION PLAN (SCALE :- NTS)

Proposal Basic Information	
Proposal File No.	MNAC/BP/0036/W09/2024
Owner Name	MR. YASH JAISWAL
Khata No	481
Plot No	461
Village Name	Pardih
Use	Residential
SubUse	Bungalow/ Dwelling / Non Apartment

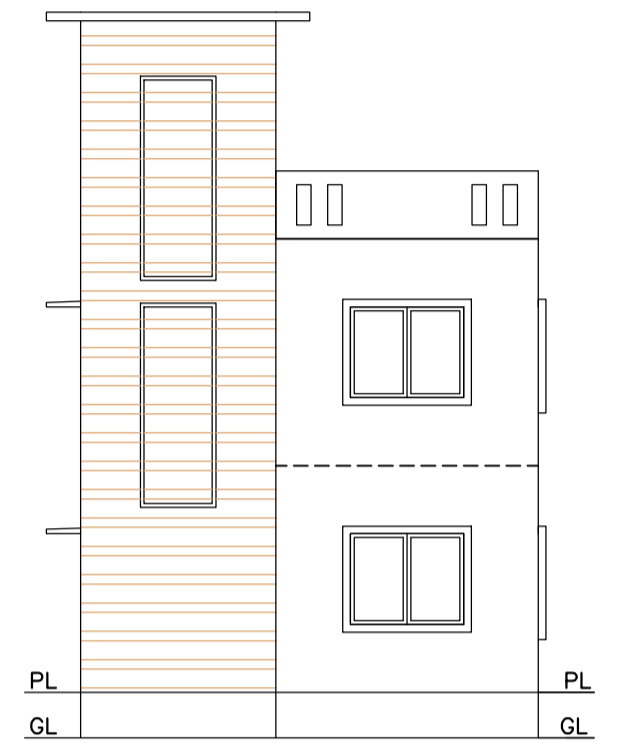

FRONT ELEVATION (SCALE 1:100)

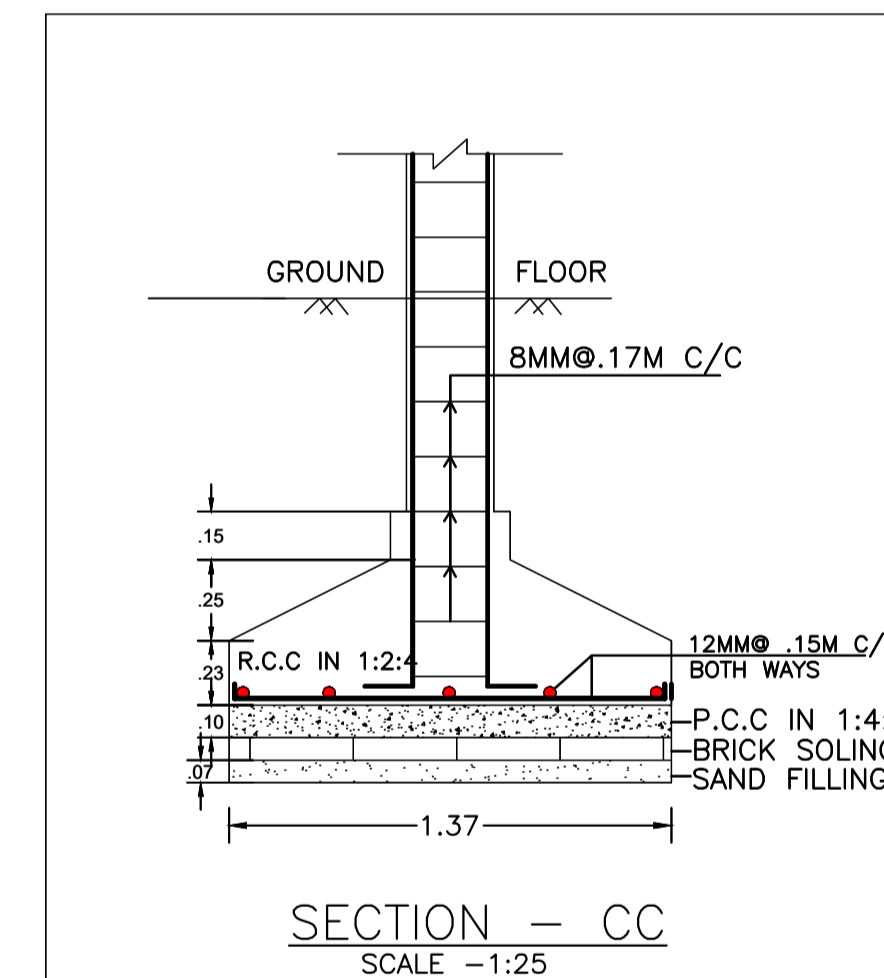

SECTION - CC (SCALE -1:25)

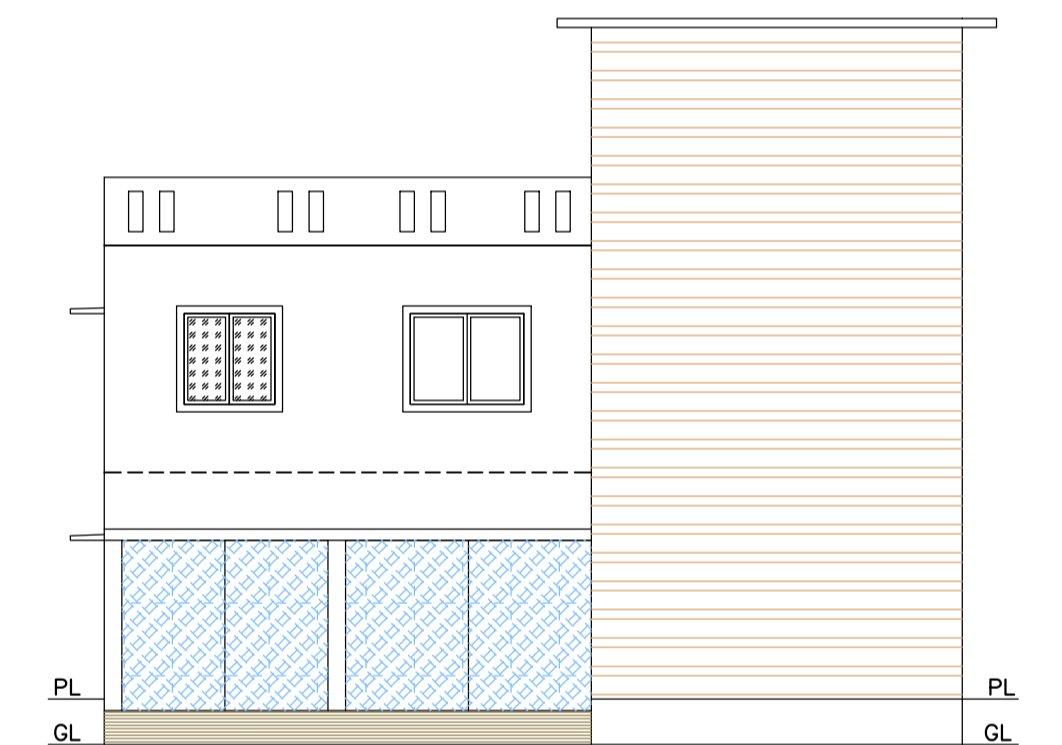

NORTH SIDE ELEVATION (SCALE 1:100)

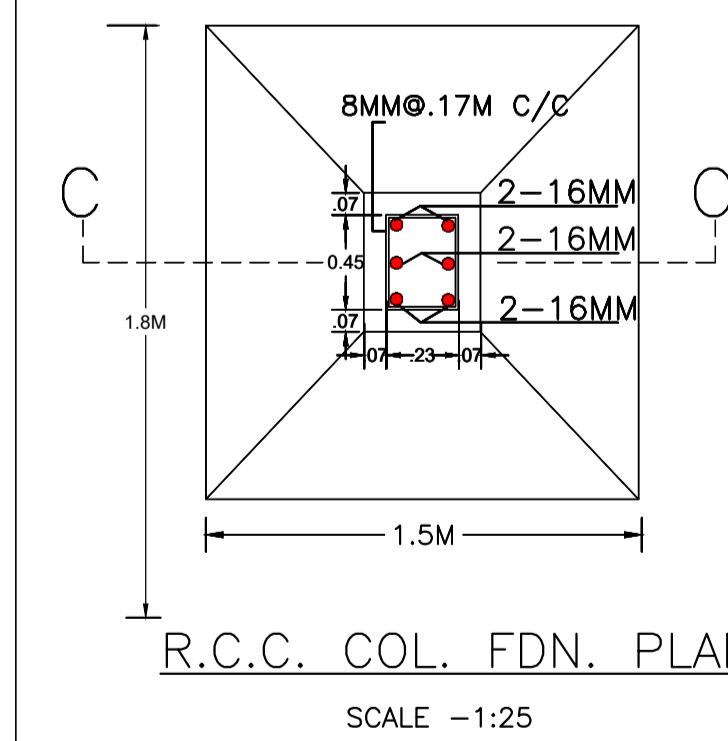

R.C.C. COL. FDN. PLAN (SCALE -1:25)

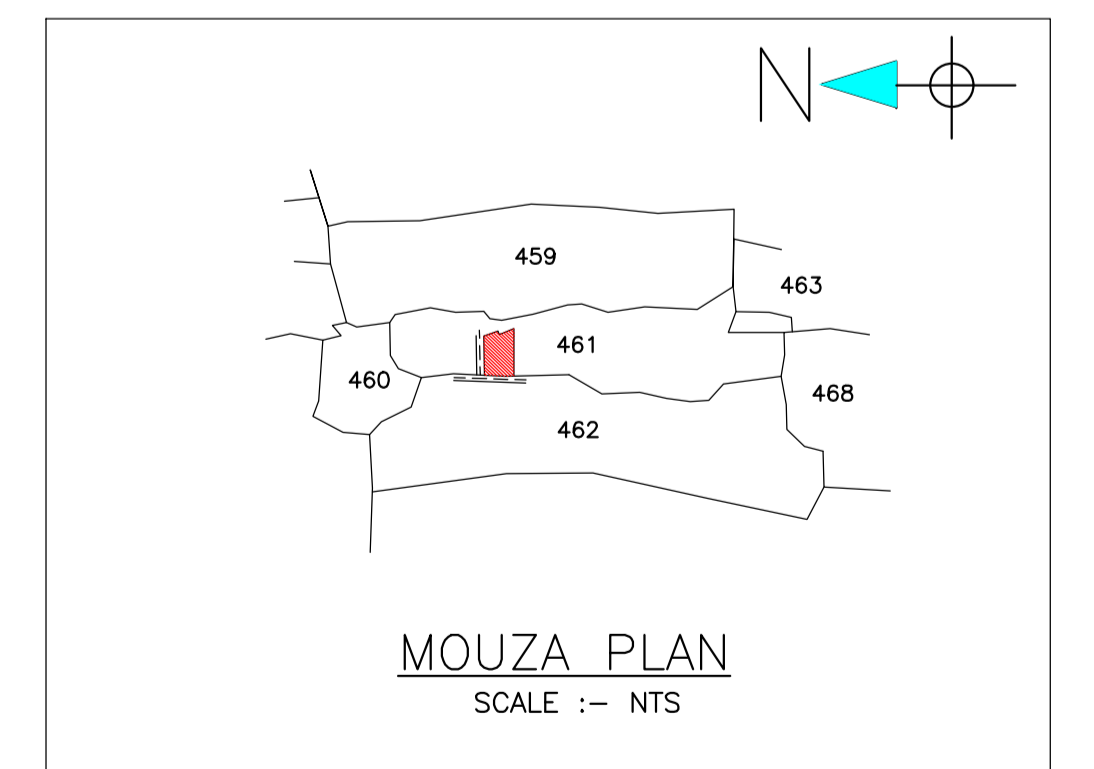

MOUZA PLAN (SCALE :- NTS)

Building :A (RESIDENTIAL)

Floor Name	Total Built Up Area (Sq.mt.)	Deductions (Area in Sq.mt.)		Proposed FAR Area (Sq.mt.)	Add Area In FAR (Sq.mt.)	Total FAR Area (Sq.mt.)	Total Consumed FAR Area (Sq.mt.)	Trmt (No.)
		Parking	Resi.					
Ground Floor	60.77	32.79	18.54	9.44	27.98	27.98	01	
First Floor	60.77	0.00	60.77	60.77	0.00	60.77	00	
Terrace Floor	0.00	0.00	0.00	0.00	0.00	0.00	00	
Total :	121.54	32.79	79.31	9.44	88.75	88.75	01	
Total Number of Same Buildings	1							
Total :	121.54	32.79	79.31	9.44	88.75	88.75	01	

SCHEDULE OF DOOR:

BUILDING NAME	NAME	LENGTH	HEIGHT	NOS
A (RESIDENTIAL)	D2	0.75	2.10	02
A (RESIDENTIAL)	D1	0.90	2.10	02
A (RESIDENTIAL)	D	1.00	2.10	03

SCHEDULE OF WINDOW/VENTILATION:

BUILDING NAME	NAME	LENGTH	HEIGHT	NOS
A (RESIDENTIAL)	V	0.60	0.90	02
A (RESIDENTIAL)	W1	1.20	1.20	03
A (RESIDENTIAL)	W1	1.50	1.20	04
A (RESIDENTIAL)	Wx	2.50	1.20	01

UnitBUA Table for Building :A (RESIDENTIAL)

FLOOR	Name	UnitBUA Type	UnitBUA Area	Carpet Area	No. of Rooms	No. of Tenement
GROUND FLOOR PLAN	SPLIT A	FLAT	57.91	55.60	2	1
FIRST FLOOR PLAN	SPLIT A	FLAT	0.00	0.00	5	0
Total:	-	-	57.91	55.60	7	1

LTP NAME AND SIGNATURE	STRUCTURAL ENG'S NAME AND SIGNATURE	BUILDER NAME AND SIGNATURE	DIGITAL SIGNATURE
Chandrika Sharma MNAC/DFTMN/0017/2017			

Proposal Basic Information

Proposal File No.	MNAC/BP/0036/W09/2024
Owner Name	MR. YASH JAISWAL
Khata No	481
Plot No	461
Village Name	Pardih
Use	Residential
SubUse	Bungalow/ Dwelling / Non Apartment

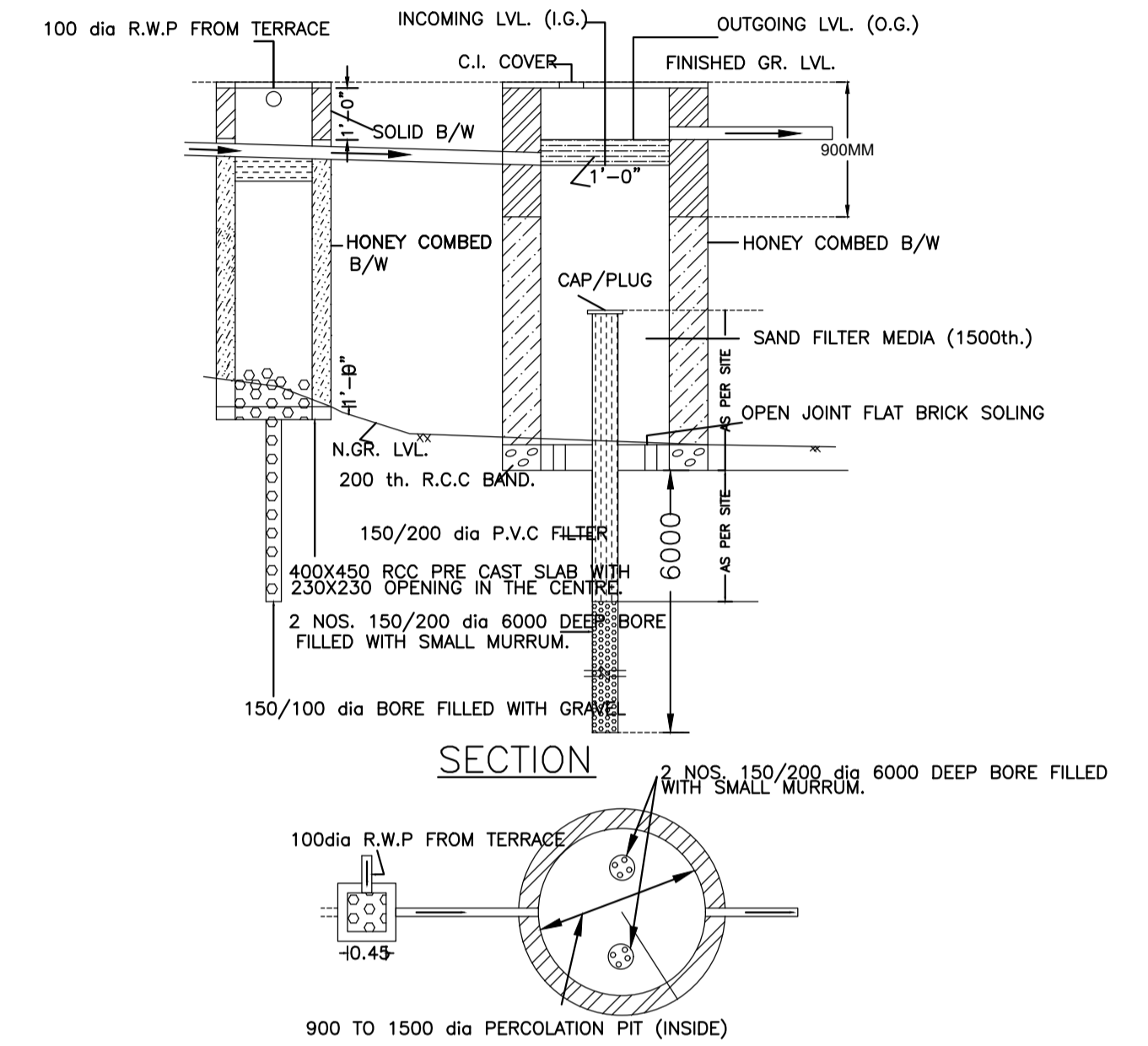

WATER HARVESTING PLAN (NTS)

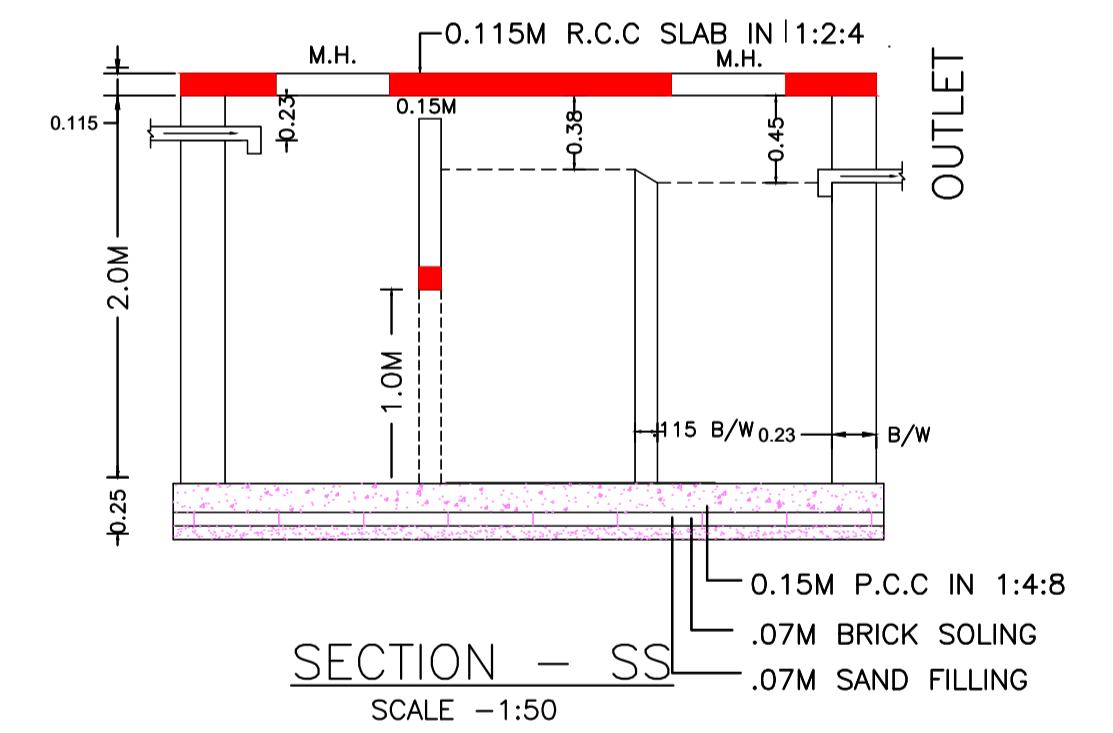

SEPTIC TANK PLAN

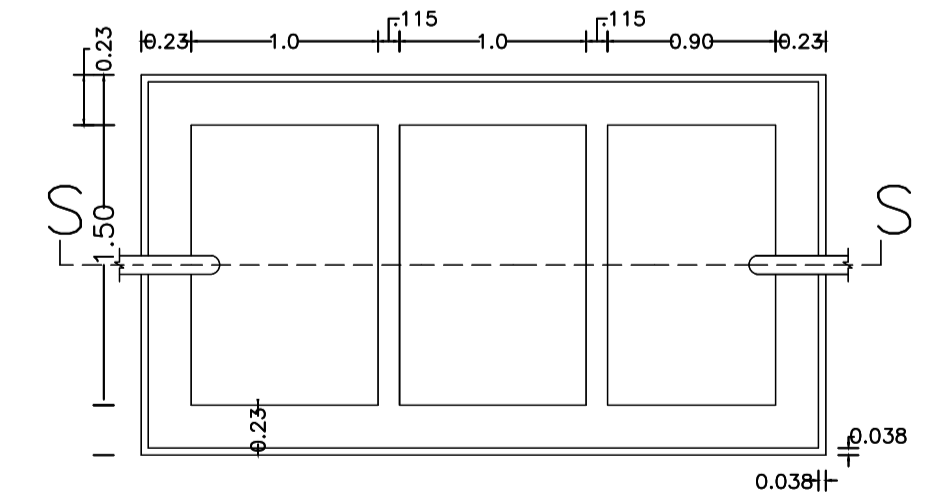

LTP NAME AND SIGNATURE	STRUCTURAL ENG'S NAME AND SIGNATURE	BUILDER NAME AND SIGNATURE	DIGITAL SIGNATURE
Chandrika Sharma MNAC/DFTMN/0017/2017			