

SITE - PLAN
SCALE 1:100

SITE PLAN

FAR & Tenement Details (Table 4c-1)

Building	No. of Same Bldg	Total Built Up Area (Sq.mt.)	Deductions (Area in Sq.mt.)		Proposed FAR Area (Sq.mt.)	Total FAR Area (Sq.mt.)	Total Consumed Additional FAR Area (Sq.mt.)	Tnmt (No.)
			Parking	Resi.				
A (RESIDENTIAL)	1	190.80	37.34	153.46	153.46	153.46	153.46	01
Grand Total :	1	190.80	37.34	153.46	153.46	153.46	153.46	01

Proposal Basic Information

Proposal File No.	MNAC/BP/0071/W08/2024
Owner Name	MRS. POONAM TIWARI
Khata No	1049
Plot No	3646, 3647, 3648
Village Name	Pardih
Use	Residential
SubUse	Bungalow/ Dwelling / Non Apartment

AREA STATEMENT MANGO MUNICIPAL CORPORATION		VERSION NO. : 1.0.70
PROJECT DETAIL:		VERSION DATE: 16/10/2020
Region: JHARKHAND URBAN LOCAL BODIES	Plot Use: Residential	
District: EAST SINGHBHUM	Plot SubUse: Bungalow/ Dwelling / Non Apartment	
Authority: MANGO MUNICIPAL CORPORATION	PlotNearbyReligiousStructure: NA	
Inward No: MNAC/BP/0071/W08/2024	PlotSubPlot No: 3646, 3647, 3648	
Application Type: General Proposal	North: -	
Project Type: Building Permission	South: -	
Nature of Development: New	East: -	
Location of Development Area: Old Area	West: -	
AREA DETAILS:		
AREA OF PLOT (Minimum)	(A)	113.84
NET AREA OF PLOT(Gross Plot Area - Deduction from Gross Plot area)	(A-Deductions)	113.84
Deduction for Balance Plot Area(from Gross Plot Area)		
Common Plot		16.00
Total		16.00
BALANCE AREA OF PLOT(Net Plot Area - Recreational/Amenity space)	(A-Deductions)	97.84
PLOT AREA FOR COVERAGE(Net Plot Area)	(A-Deductions)	113.84
Plot Area for FAR (Net Plot Area + RoadWidening Area)	(A-Deductions)	113.84
COVERAGE CHECK		
Permissible Coverage area (70.00 %)		79.69
Proposed Coverage Area (55.87 %)		63.60
Total Prop. Coverage Area (55.87 %)		63.60
Balance coverage area (14.13 %)		16.09
FAR CHECK		
Perm. FAR Area (2.500)		284.60
Total Perm. FAR area		284.60
Residential FAR		153.45
Proposed FAR Area		153.45
Total Proposed FAR Area		153.45
Consumed FAR (Factor)		1.35
Balance FAR Area		131.15
BUILT UP AREA CHECK		
Total Proposed BuiltUp Area		190.80
ARCHITECT (Regd)	EJAZ AHMAD	
ENGINEER (Regd)		
SUPERVISOR (Regd)		
OWNER (Regd)	MRS. POONAM TIWARI	
DEVELOPMENT AUTHORITY		LOCAL BODY

COLOR INDEX	
PLOT BOUNDARY	Black
ABUTTING ROAD	Green
PROPOSED CONSTRUCTION	Red
COMMON PLOT	Yellow
ROAD WIDENING AREA	Orange
EXISTING (To be retained)	Blue
EXISTING (To be demolished)	Light Blue

Buildingwise Floor FAR Details

Floor Name	Building Name A (RESIDENTIAL)		Total	
	Proposed Built Up Area (Sq.mt.)	Proposed FAR Area (Sq.mt.)	Total Proposed Built Up Area (Sq.mt.)	Total FAR Area (Sq.mt.)
Ground Floor	63.60	26.26	63.60	26.26
First Floor	63.60	63.60	63.60	63.60
Second Floor	63.60	63.60	63.60	63.60
Terrace Floor	0.00	0.00	0.00	0.00
Total :	190.80	153.46	190.80	153.46

Building USE/SUBUSE Details

Building Name	Building Use	Building SubUse	Building Structure
A (RESIDENTIAL)	Residential	Bungalow/ Dwelling / Non Apartment	Non-Highrise

LTP NAME AND SIGNATURE	STRUCTURAL ENG'S NAME AND SIGNATURE	BUILDER NAME AND SIGNATURE	DIGITAL SIGNATURE
EJAZ AHMAD MNAC/DFTMN/0008/2020			

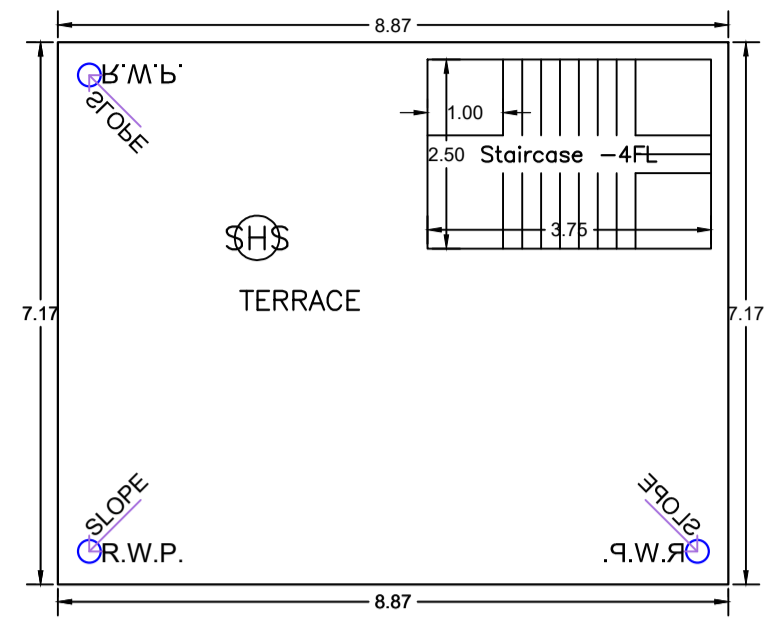
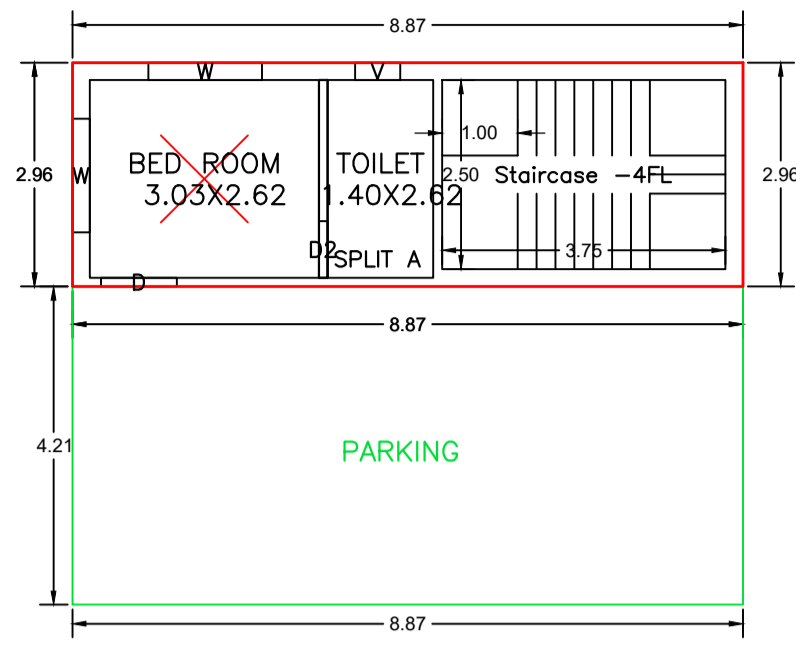

TERRACE FLOOR PLAN (SCALE 1:100)

GROUND FLOOR PLAN (Proposed) (SCALE 1:100)

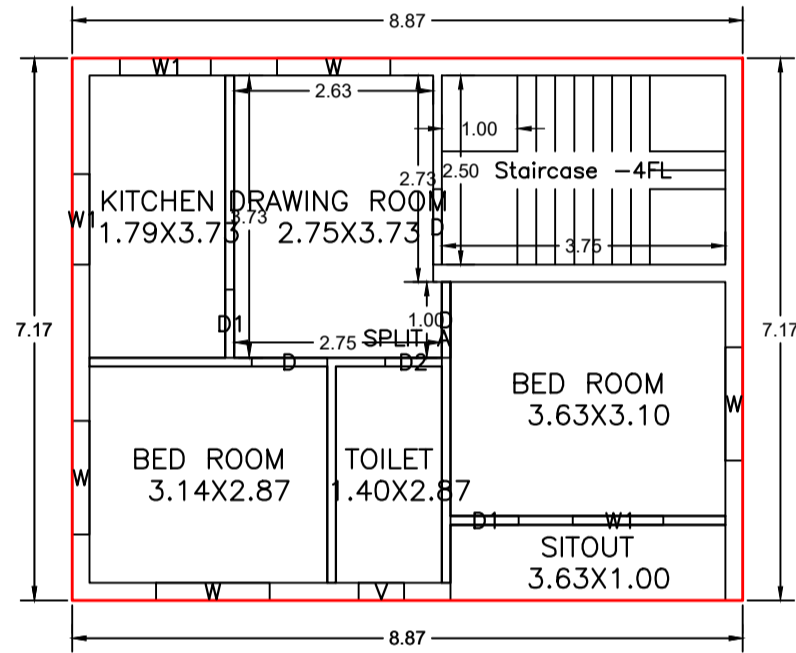

TYPICAL - 1 & 2 FLOOR PLAN (Proposed) (SCALE 1:100)

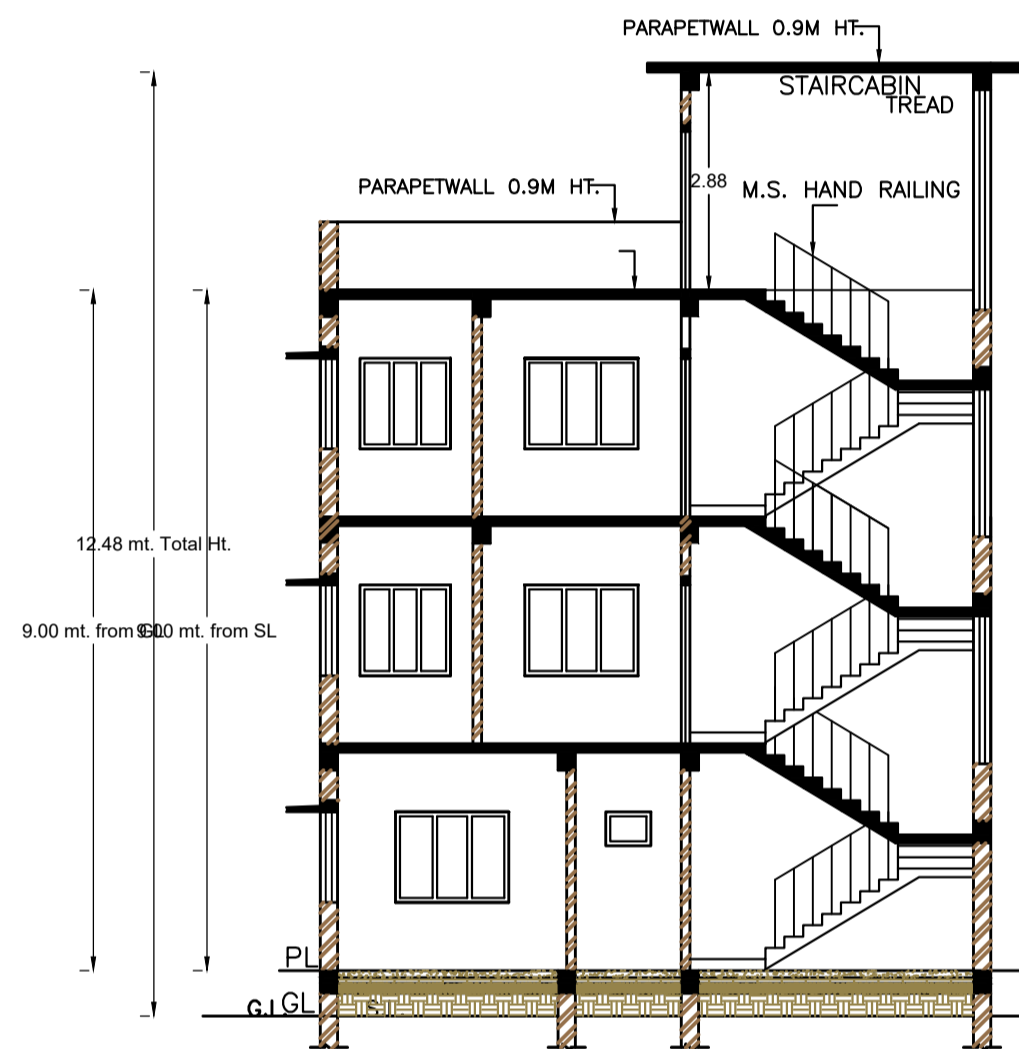

SECTION - AA SCALE 1:100

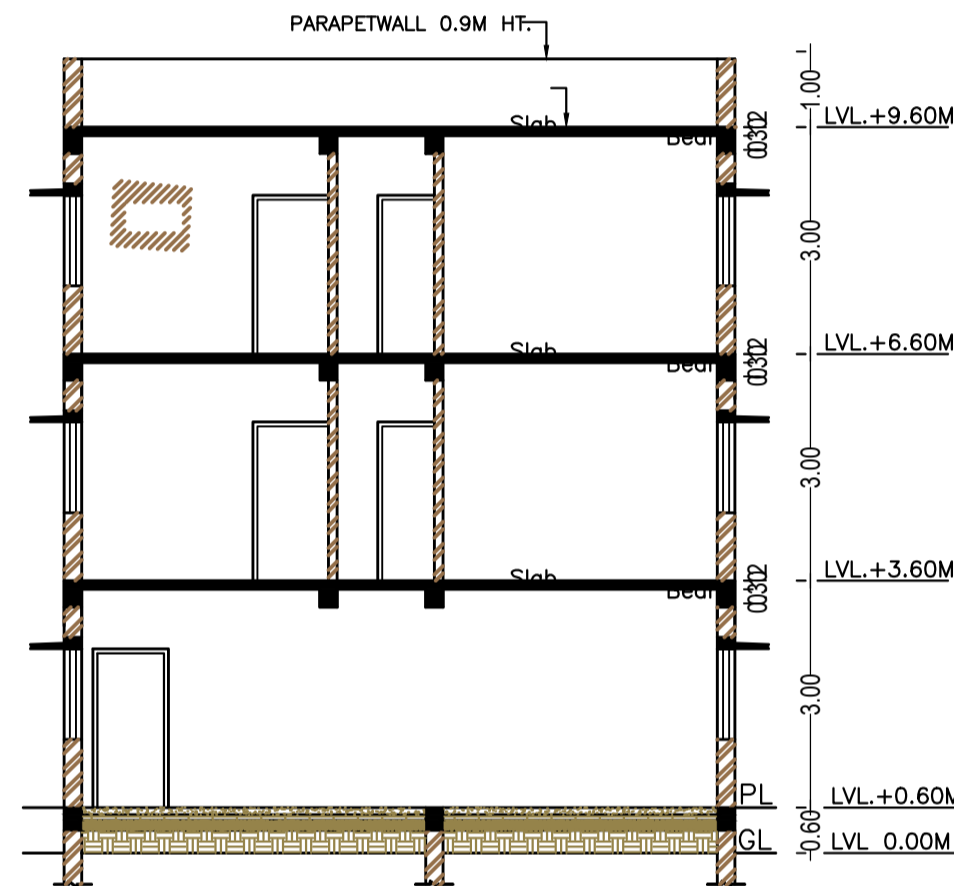

SECTION - BB SCALE 1:100

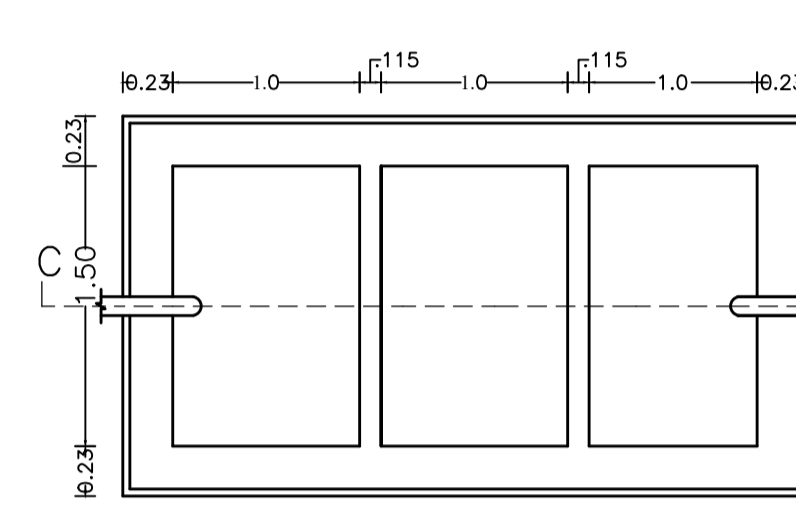

SEPTIC TANK PLAN SCALE -1:50

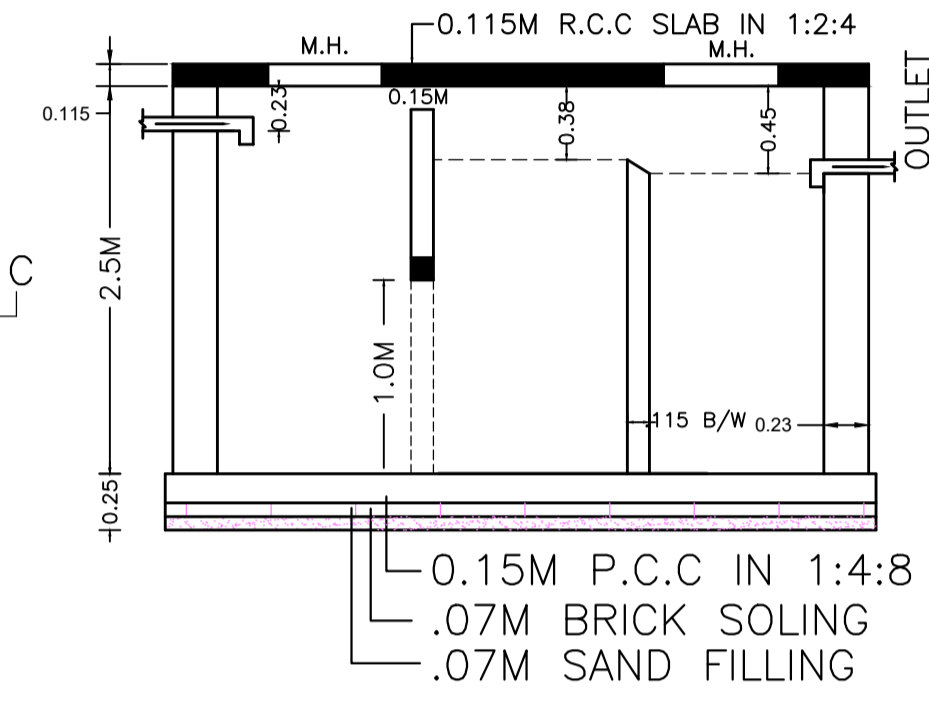

SECTION - SS SCALE -1:50

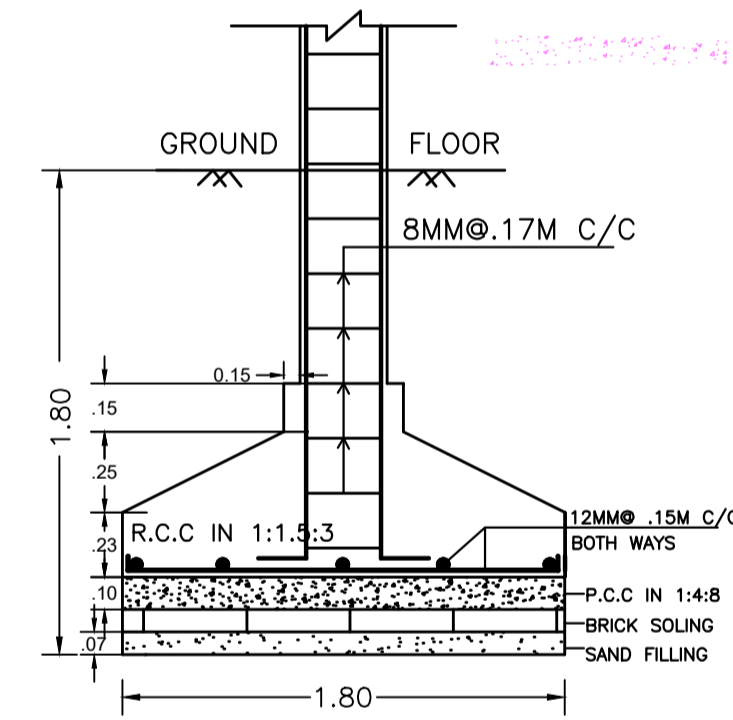

SECTION - CC SCALE -1:25

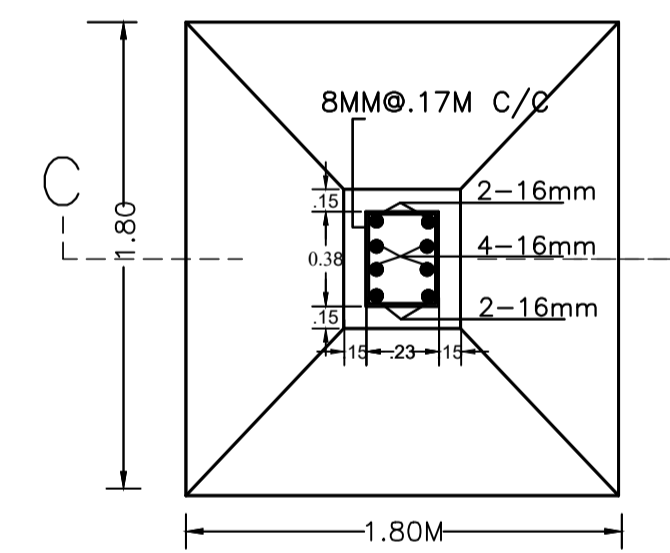

R.C.C. COL. FDN. PLAN SCALE -1:25

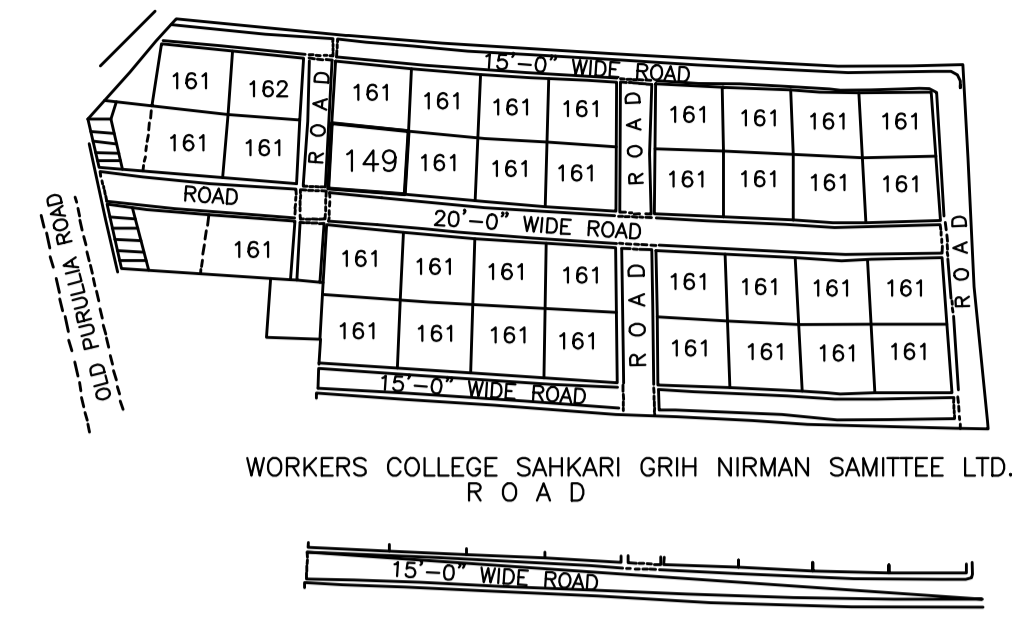

MOUZA PLAN (NTS)

Proposal Basic Information	
Proposal File No.	MNAC/BP/0071/W08/2024
Owner Name	MRS. POONAM TIWARI
Khata No	1049
Plot No	3646, 3647, 3648
Village Name	Pardih
Use	Residential
SubUse	Bungalow/ Dwelling / Non Apartment

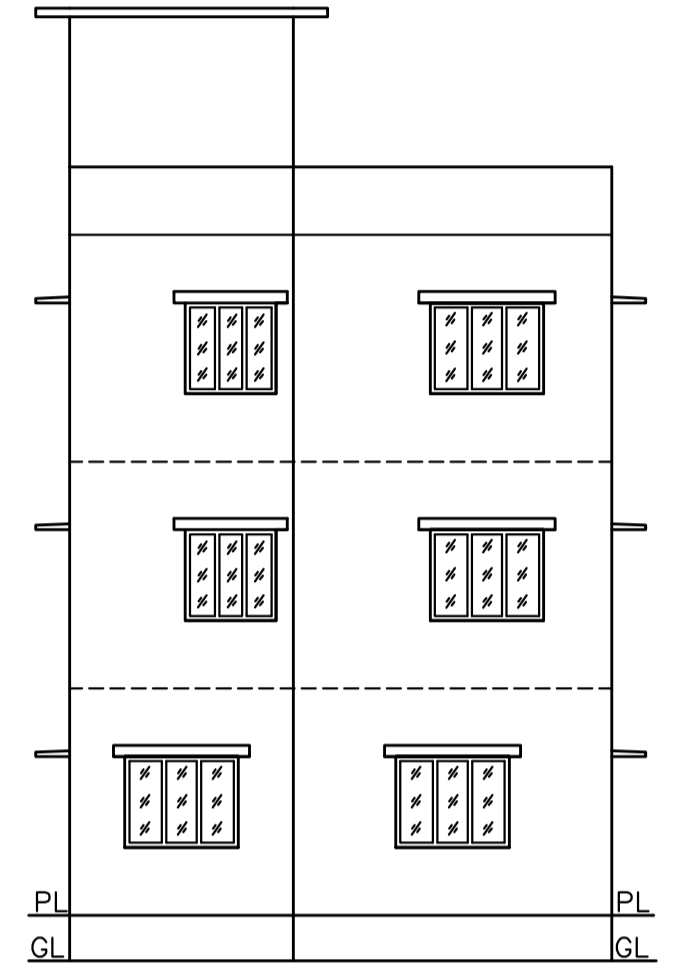

NORTH SIDE ELEVATION SCALE 1:100

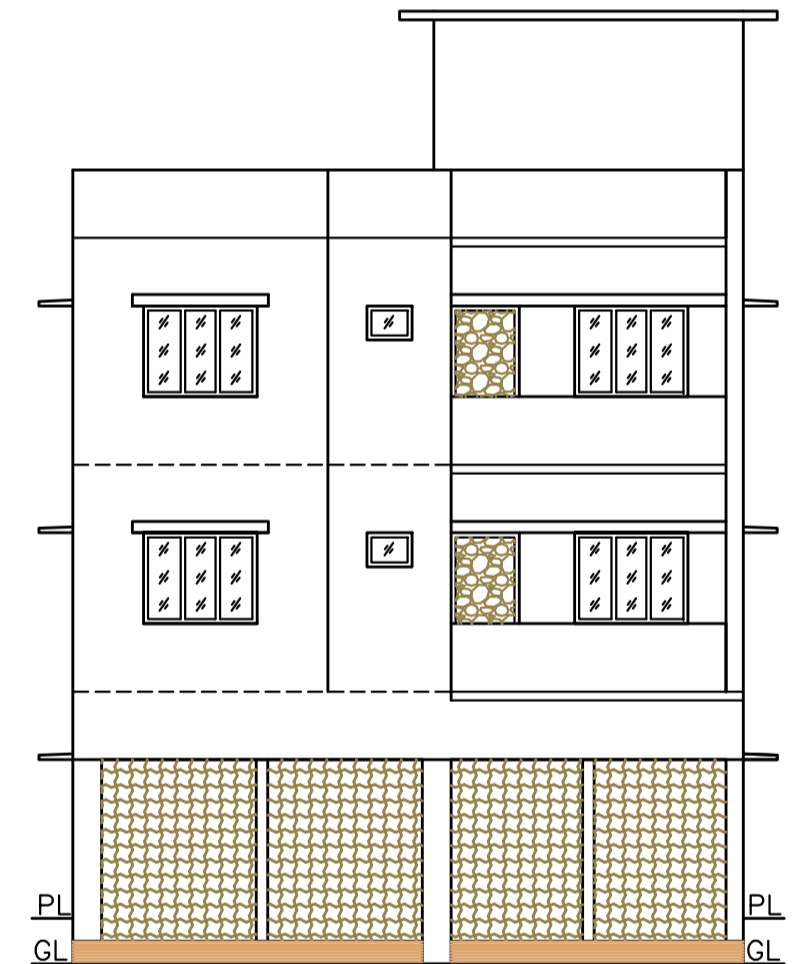

FRONT ELEVATION SCALE 1:100

Building :A (RESIDENTIAL)

Floor Name	Total Built Up Area (Sq.mt.)	Deductions (Area in Sq.mt.)	Proposed FAR Area (Sq.mt.)	Total FAR Area (Sq.mt.)	Total Consumed Additional FAR Area (Sq.mt.)	Trmt (No.)
Ground Floor	63.60	37.34	26.26	26.26	26.26	01
First Floor	63.60	0.00	63.60	63.60	63.60	00
Second Floor	63.60	0.00	63.60	63.60	63.60	00
Terrace Floor	0.00	0.00	0.00	0.00	0.00	00
Total:	190.80	37.34	153.46	153.46	153.46	01
Total Number of Same Buildings	1					
Total:	190.80	37.34	153.46	153.46	153.46	01

SCHEDULE OF DOOR:

BUILDING NAME	NAME	LENGTH	HEIGHT	NOS
A (RESIDENTIAL)	D2	0.75	2.10	03
A (RESIDENTIAL)	D1	0.90	2.10	04
A (RESIDENTIAL)	D	1.00	2.10	07

SCHEDULE OF WINDOW/VENTILATION:

BUILDING NAME	NAME	LENGTH	HEIGHT	NOS
A (RESIDENTIAL)	V	0.60	0.90	03
A (RESIDENTIAL)	W1	1.20	1.20	06
A (RESIDENTIAL)	W	1.50	1.20	10

UnitBUA Table for Building :A (RESIDENTIAL)

FLOOR	Name	UnitBUA Type	UnitBUA Area	Carpet Area	No. of Rooms	No. of Tenement
GROUND FLOOR PLAN	SPLIT A	FLAT	105.32	100.68	2	1
TYPICAL - 1 & 2 FLOOR PLAN	SPLIT A	FLAT	0.00	0.00	6	0
Total:	-	-	105.32	100.68	14	1

LTP NAME AND SIGNATURE	STRUCTURAL ENG'S NAME AND SIGNATURE	BUILDER NAME AND SIGNATURE	DIGITAL SIGNATURE
EJAZ AHMAD MNAC/DFTMN/0008/2020			

Proposal Basic Information	
Proposal File No.	MNAC/BP/0071/W08/2024
Owner Name	MRS. POONAM TIWARI
Khata No	1049
Plot No	3646, 3647, 3648
Village Name	Pardih
Use	Residential
SubUse	Bungalow/ Dwelling / Non Apartment

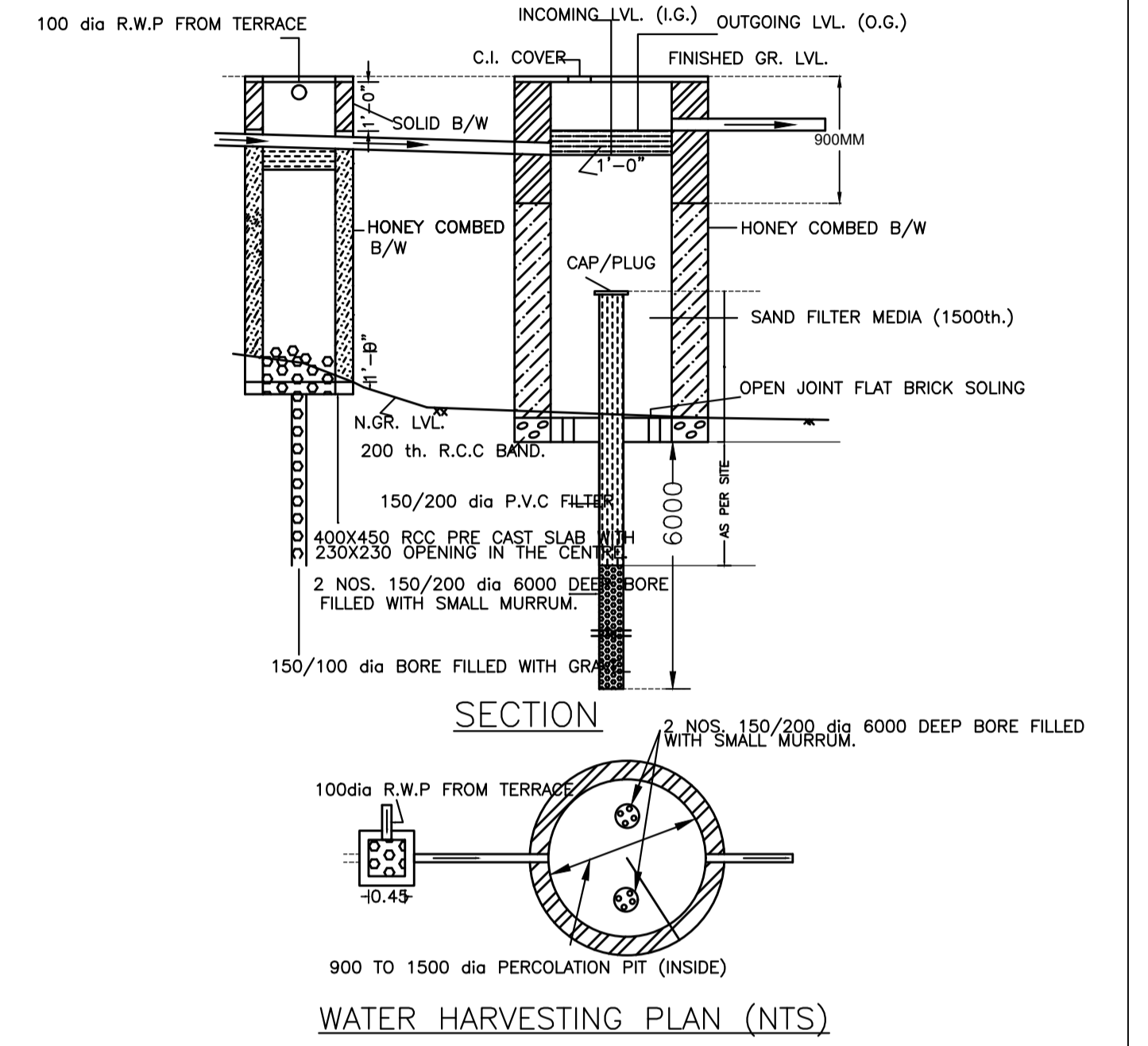

LTP NAME AND SIGNATURE	STRUCTURAL ENG'S NAME AND SIGNATURE	BUILDER NAME AND SIGNATURE	DIGITAL SIGNATURE
EJAZ AHMAD MNAC/DFTMN/0008/2020			