

SITE - PLAN
SCALE 1:100

SITE PLAN

FAR & Tenement Details (Table 4c-1)

Building	No. of Same Bldg	Total Built Up Area (Sq.mt.)	Deductions (Area in Sq.mt.)		Proposed FAR Area (Sq.mt.)	Total FAR Area (Sq.mt.)	Total Consumed Additional FAR Area (Sq.mt.)	Trmnt (No.)
			Balcony	Parking				
A (RESIDENTIAL)	1	513.54	10.38	50.69	452.47	452.47	452.47	01
Grand Total :	1	513.54	10.38	50.69	452.47	452.47	452.47	01

Proposal Basic Information

Proposal File No.	MNAC/BI/0069/W09/2024
Owner Name	SNEHI NILANJANA MINZ
Khata No	412
Plot No	2034
Village Name	Mango
Use	Residential
SubUse	Bungalow/ Dwelling / Non Apartment

AREA STATEMENT MANGO MUNICIPAL CORPORATION	VERSION NO: 1.0.70
PROJECT DETAIL:	VERSION DATE: 16/10/2020
Region: JHARKHAND URBAN LOCAL BODIES	Plot Use: Residential
District: EAST SINGHBHUM	Plot SubUse: Bungalow/ Dwelling / Non Apartment
Authority: MANGO MUNICIPAL CORPORATION	PlotNearbyReligiousStructure: NA
Inward No: MNAC/BI/0069/W09/2024	PlotSubPlot No: 2034
Application Type: General Proposal	North: -
Project Type: Building Permission	South: -
Nature of Development: New	East: -
Location of Development Area: Old Area	West: -
AREA DETAILS:	SQ.MT.
AREA OF PLOT (Minimum)	(A) 302.80
NET AREA OF PLOT(Gross Plot Area - Deduction from Gross Plot area)	(A-Deductions) 302.80
Deduction for Balance Plot Area(from Gross Plot Area)	
Common Plot	36.57
Total	36.57
BALANCE AREA OF PLOT(Net Plot Area - Recreational/Amenity space)	(A-Deductions) 266.23
PLOT AREA FOR COVERAGE(Net Plot Area)	(A-Deductions) 302.80
Plot Area for FAR (Net Plot Area + RoadWidening Area)	(A-Deductions) 302.80
COVERAGE CHECK	
Permissible Coverage area (60.00 %)	181.68
Proposed Coverage Area (54.25 %)	164.26
Total Prop. Coverage Area (54.25 %)	164.26
Balance coverage area (5.75 %)	17.42
FAR CHECK	
Perm. FAR Area (2.500)	757.00
Total Perm. FAR area	757.00
Residential FAR	452.46
Proposed FAR Area	452.46
Total Proposed FAR Area	452.46
Consumed FAR (Factor)	1.49
Balance FAR Area	304.54
BUILT UP AREA CHECK	
Total Proposed BuiltUp Area	513.54
ARCHITECT (Regd)	EJAZ AHMAD
ENGINEER (Regd)	
SUPERVISOR (Regd)	
OWNER (Regd)	SNEHI NILANJANA MINZ
DEVELOPMENT AUTHORITY	LOCAL BODY

COLOR INDEX	
PLOT BOUNDARY	
ABUTTING ROAD	
PROPOSED CONSTRUCTION	
COMMON PLOT	
ROAD WIDENING AREA	
EXISTING (To be retained)	
EXISTING (To be demolished)	

Buildingwise Floor FAR Details

Floor Name	Building Name A (RESIDENTIAL)		Total	
	Proposed Built Up Area (Sq.mt.)	Proposed FAR Area (Sq.mt.)	Total Proposed Built Up Area (Sq.mt.)	Total FAR Area (Sq.mt.)
Ground Floor	164.26	113.57	164.26	113.57
First Floor	174.64	169.45	174.64	169.45
Second Floor	174.64	169.45	174.64	169.45
Terrace Floor	0.00	0.00	0.00	0.00
Total :	513.54	452.47	513.54	452.47

Building USE/SUBUSE Details

Building Name	Building Use	Building SubUse	Building Structure
A (RESIDENTIAL)	Residential	Bungalow/ Dwelling / Non Apartment	Non-Highrise

LTP NAME AND SIGNATURE	STRUCTURAL ENG'S NAME AND SIGNATURE	BUILDER NAME AND SIGNATURE	DIGITAL SIGNATURE
EJAZ AHMAD MNAC/DFTMN/0008/2020			

Proposal Basic Information	
Proposal File No.	MNAC/BP/0069/W09/2024
Owner Name	SNEHI NILANJANA MINZ
Khata No	412
Plot No	2034
Village Name	Mango
Use	Residential
SubUse	Bungalow/ Dwelling / Non Apartment

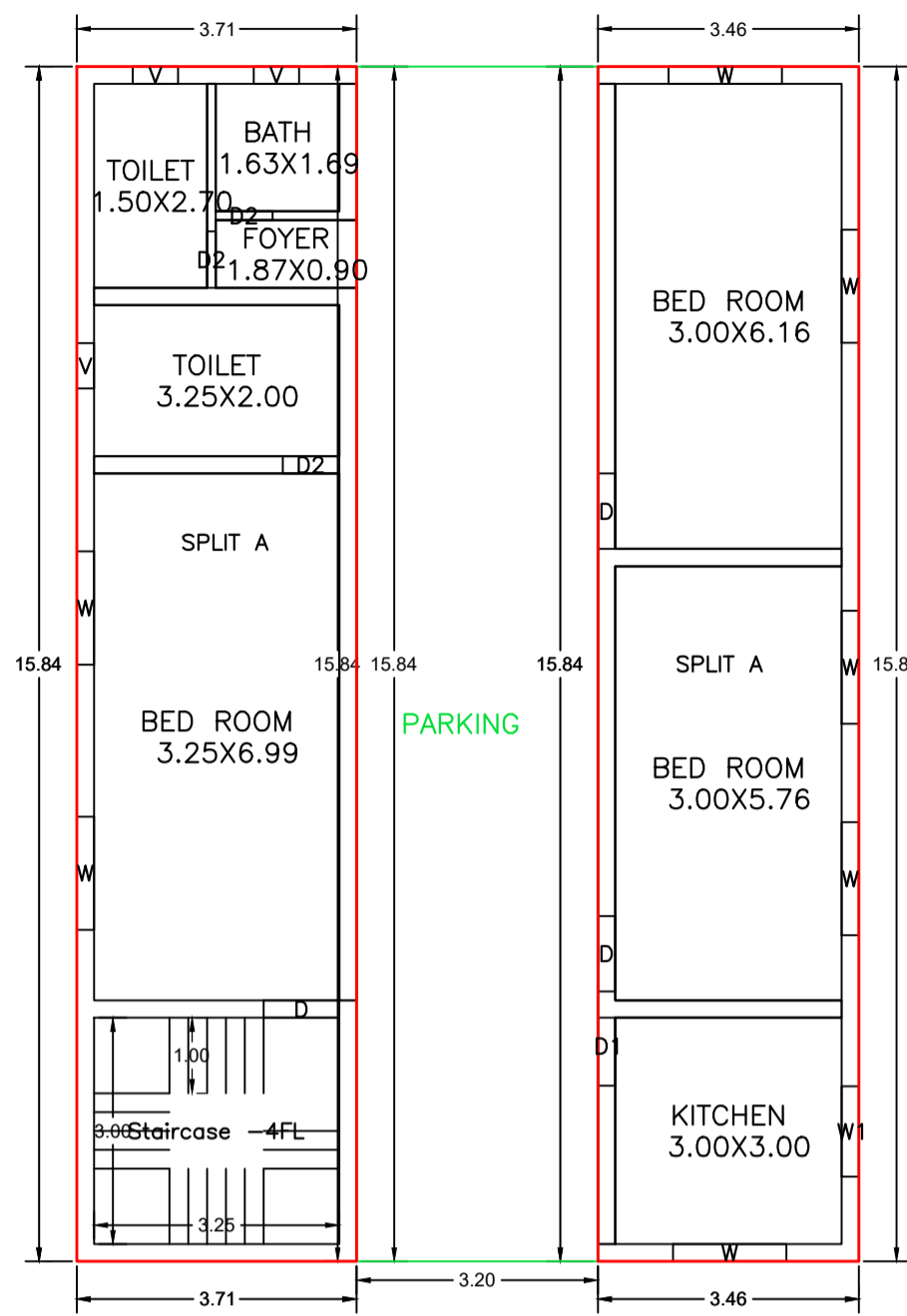

FIRST FLOOR PLAN
(Proposed)
(SCALE 1:100)

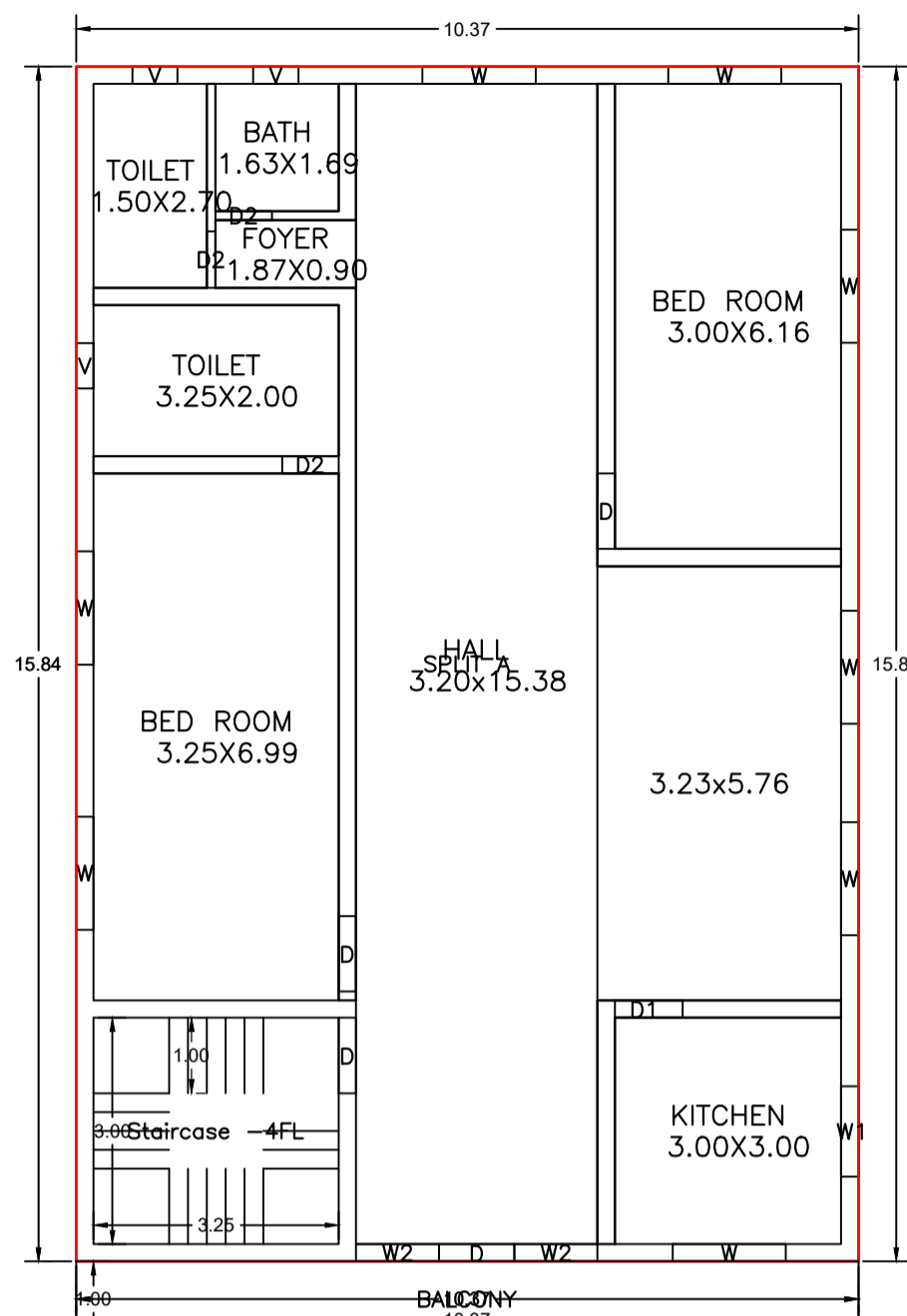

SECOND FLOOR PLAN
(Proposed)
(SCALE 1:100)

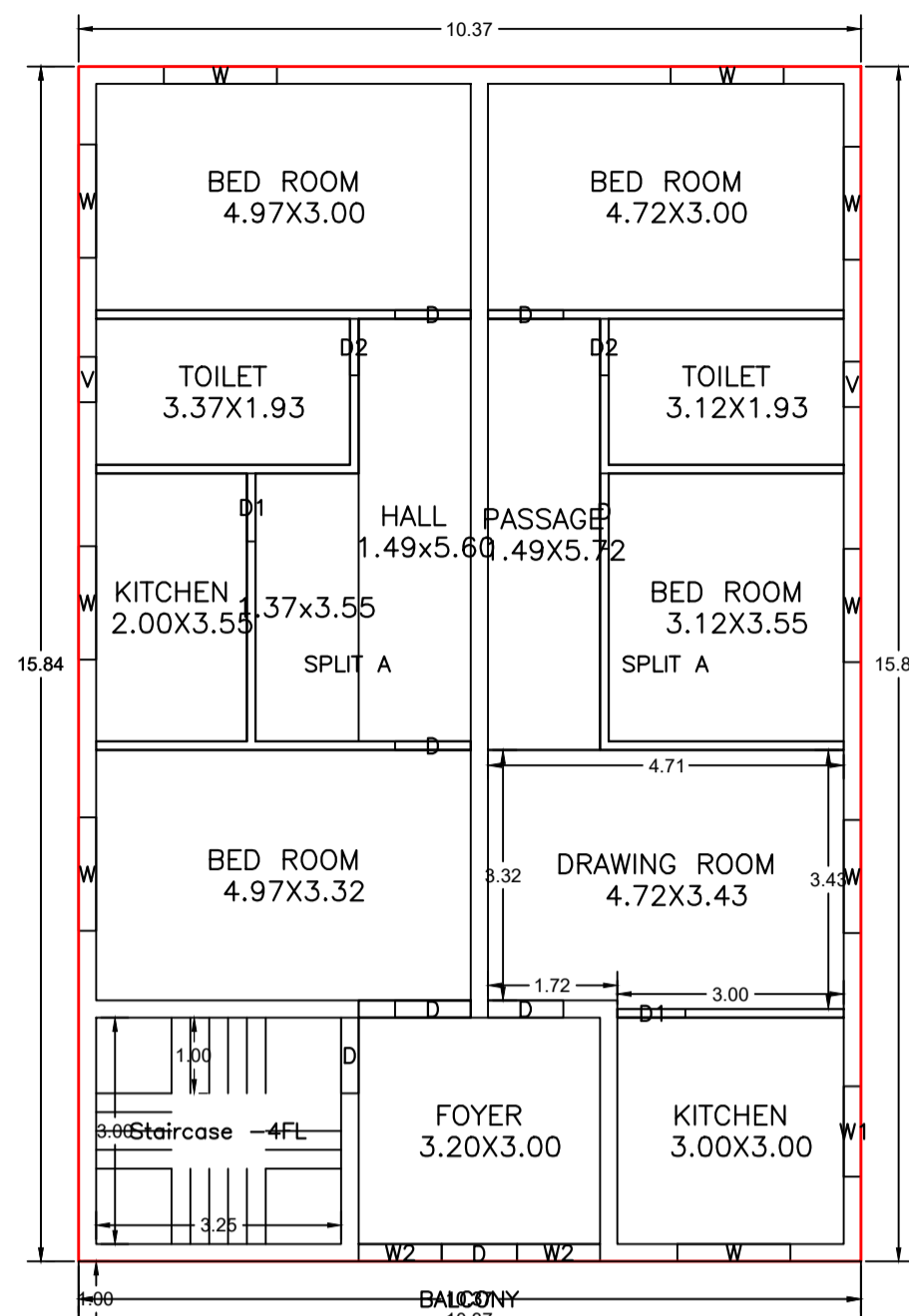

TERRACE FLOOR PLAN
(SCALE 1:100)

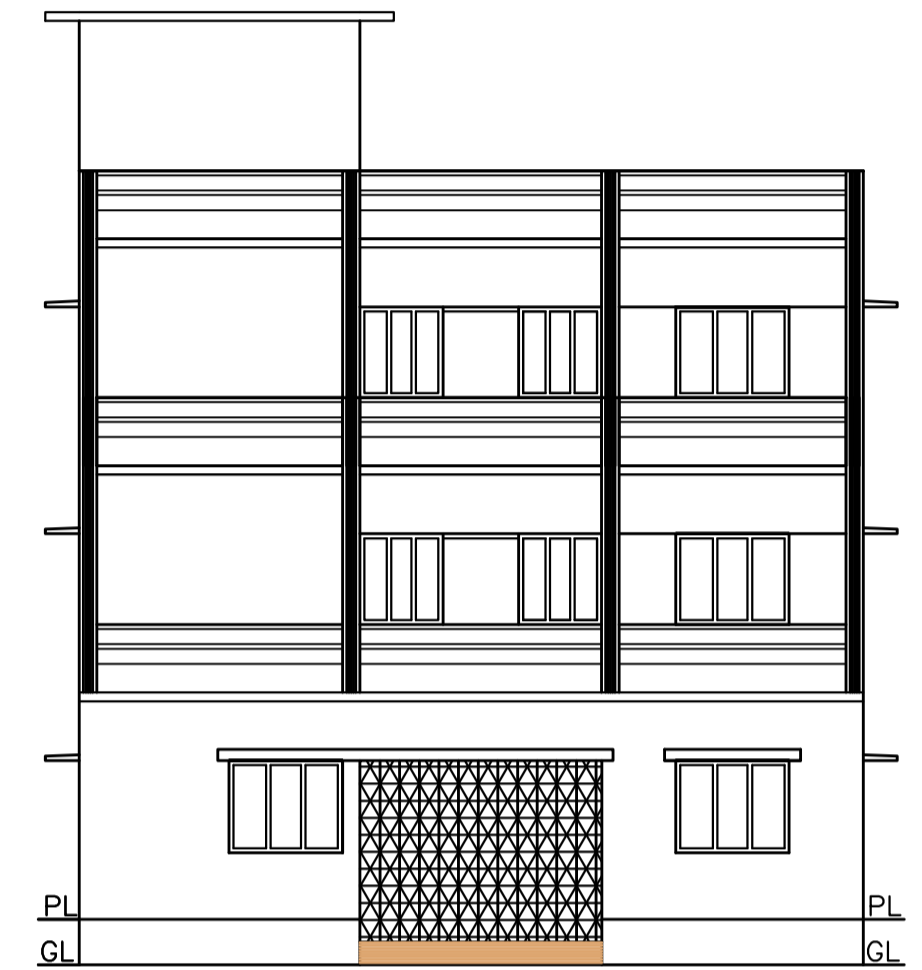

FRONT ELEVATION
SCALE 1:100

GROUND FLOOR PLAN
(Proposed)
(SCALE 1:100)

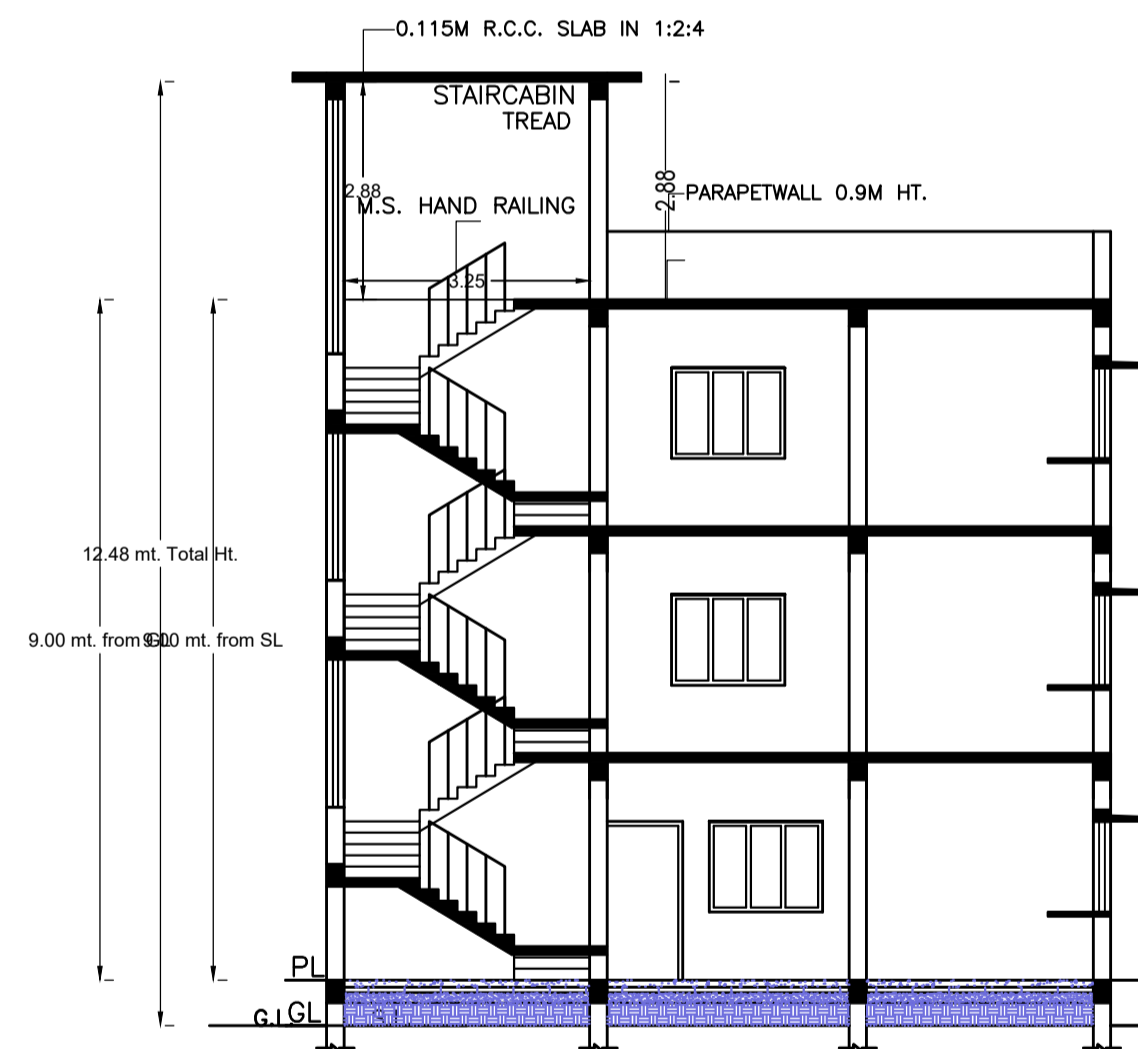

SECTION-AA
SCALE 1:100

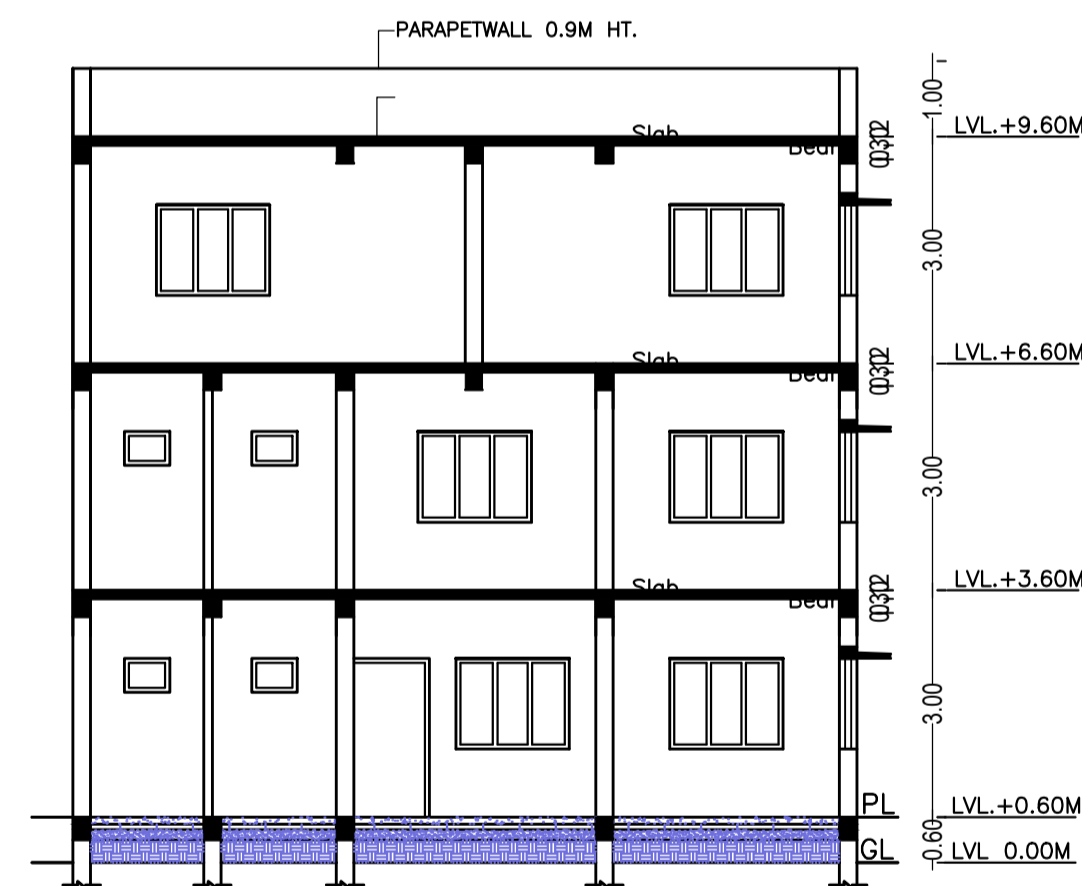

SECTION-BB
SCALE 1:100

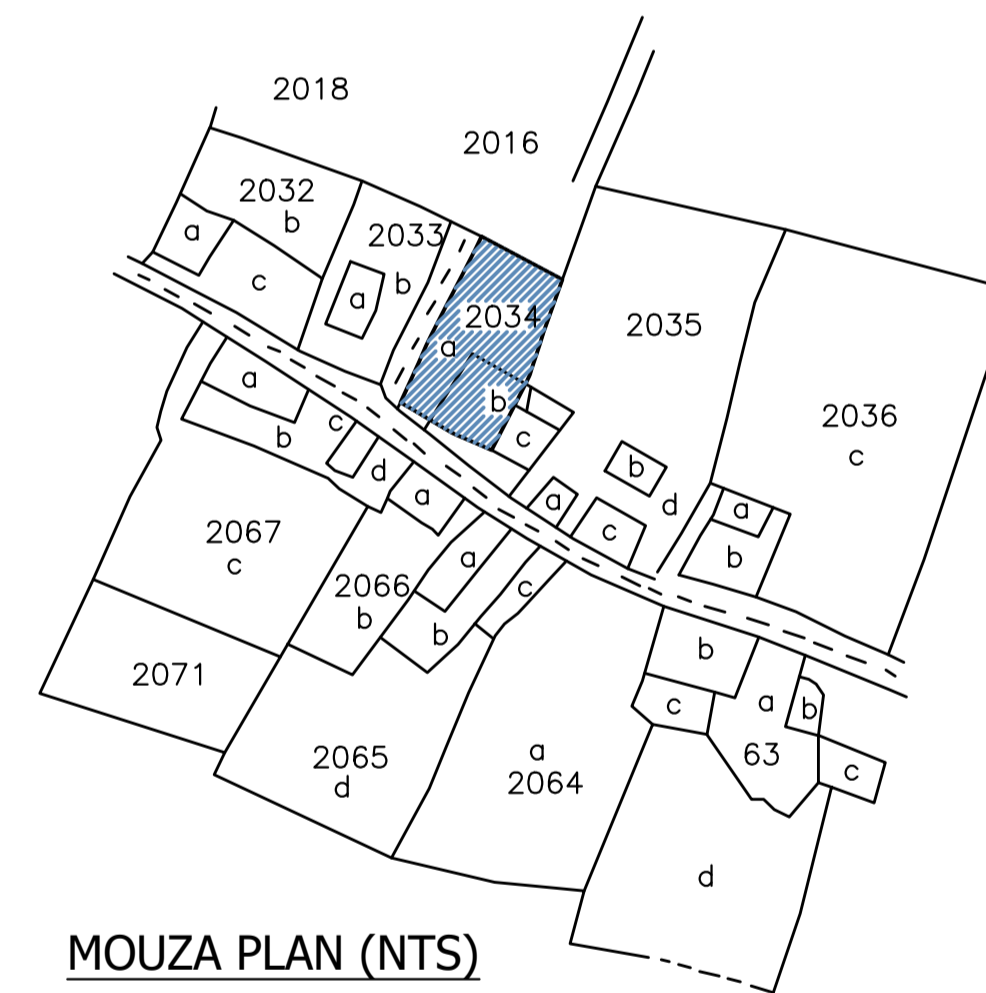

MOUZA PLAN (NTS)

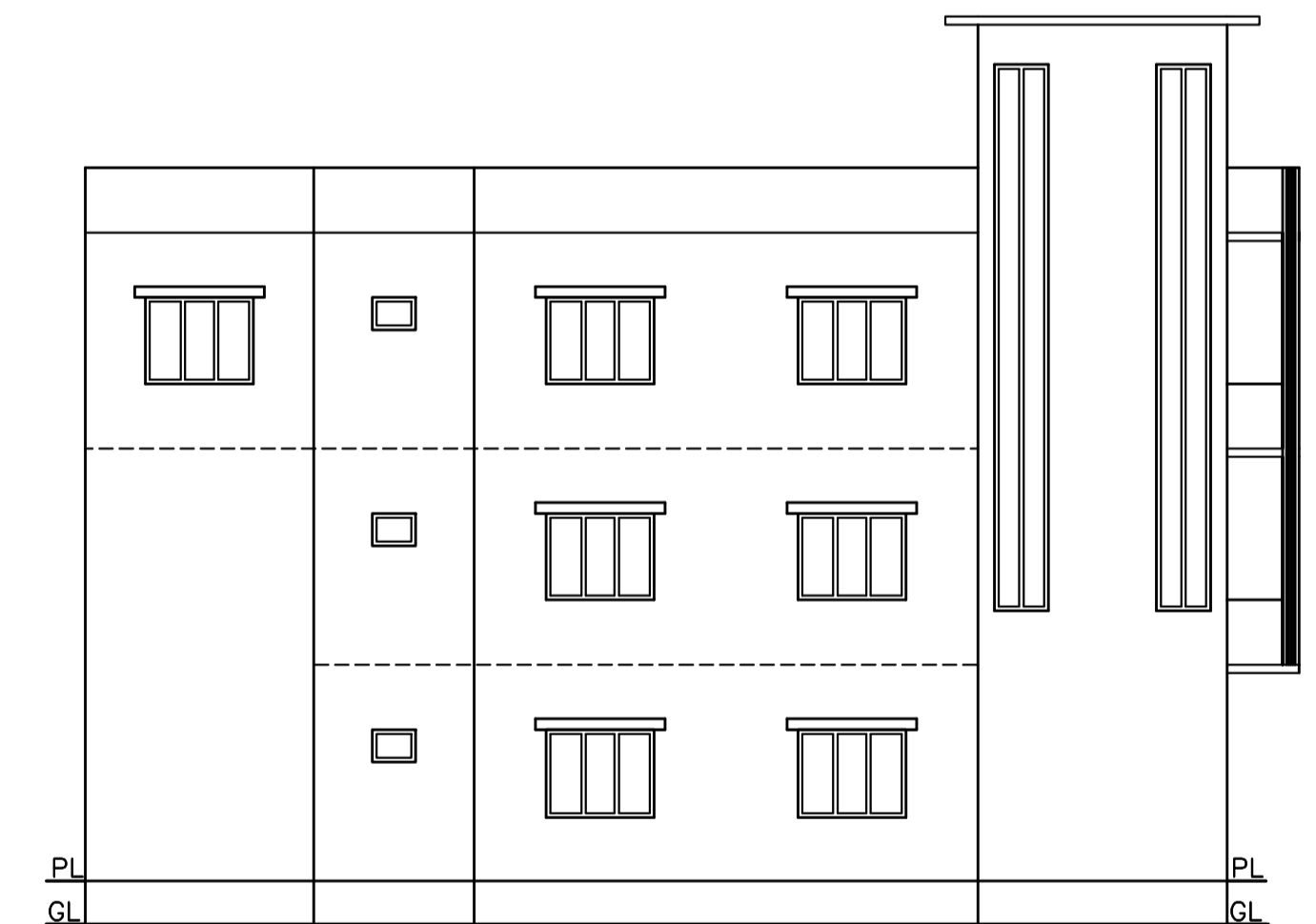

WEST SIDE ELEVATION
SCALE 1:100

Building :A (RESIDENTIAL)

Floor Name	Total Built Up Area (Sq.mt.)	Deductions (Area in Sq.mt.)		Proposed FAR Area (Sq.mt.)	Total FAR Area (Sq.mt.)	Total Consumed Additional FAR Area (Sq.mt.)	Trmt (No.)
		Balcony	Parking				
Ground Floor	164.26	0.00	50.69	113.57	113.57	113.57	01
First Floor	174.64	5.19	0.00	169.45	169.45	169.45	00
Second Floor	174.64	5.19	0.00	169.45	169.45	169.45	00
Terrace Floor	0.00	0.00	0.00	0.00	0.00	0.00	00
Total :	513.54	10.38	50.69	452.47	452.47	452.47	01
Total Number of Same Buildings	1						
Total :	513.54	10.38	50.69	452.47	452.47	452.47	01

SCHEDULE OF DOOR:

BUILDING NAME	NAME	LENGTH	HEIGHT	NOS
A (RESIDENTIAL)	D2	0.75	2.10	08
A (RESIDENTIAL)	D1	0.90	2.10	04
A (RESIDENTIAL)	D	1.00	2.10	15

SCHEDULE OF WINDOW/VENTILATION:

BUILDING NAME	NAME	LENGTH	HEIGHT	NOS
A (RESIDENTIAL)	V	0.60	0.90	08
A (RESIDENTIAL)	W2	1.10	1.20	04
A (RESIDENTIAL)	W1	1.20	1.20	03
A (RESIDENTIAL)	W	1.50	1.20	24

Balcony Calculations Table

FLOOR	SIZE	AREA	TOTAL AREA
FIRST FLOOR PLAN	1.00 X 10.37 X 1 X 1	10.37	10.37
SECOND FLOOR PLAN	1.00 X 10.37 X 1 X 1	10.37	10.37
Total	-	-	20.74

UnitBUA Table for Building :A (RESIDENTIAL)

FLOOR	Name	UnitBUA Type	UnitBUA Area	Carpet Area	No. of Rooms	No. of Tenement
GROUND FLOOR PLAN	SPLIT A	FLAT	370.38	347.93	5	1
FIRST FLOOR PLAN	SPLIT A	FLAT	0.00	0.00	3	0
SECOND FLOOR PLAN	SPLIT A	FLAT	0.00	0.00	8	0
TERRACE FLOOR PLAN	SPLIT A	FLAT	0.00	0.00	6	0
Total:	-	-	370.38	347.93	28	1

LTP NAME AND SIGNATURE	STRUCTURAL ENG'S NAME AND SIGNATURE	BUILDER NAME AND SIGNATURE	DIGITAL SIGNATURE
EJAZ AHMAD MNAC/DFTMN/0008/2020			

Proposal Basic Information	
Proposal File No.	MNAC/BP/0069/W09/2024
Owner Name	SNEHI NILANJANA MINZ
Khata No	412
Plot No	2034
Village Name	Mango
Use	Residential
SubUse	Bungalow/ Dwelling / Non Apartment

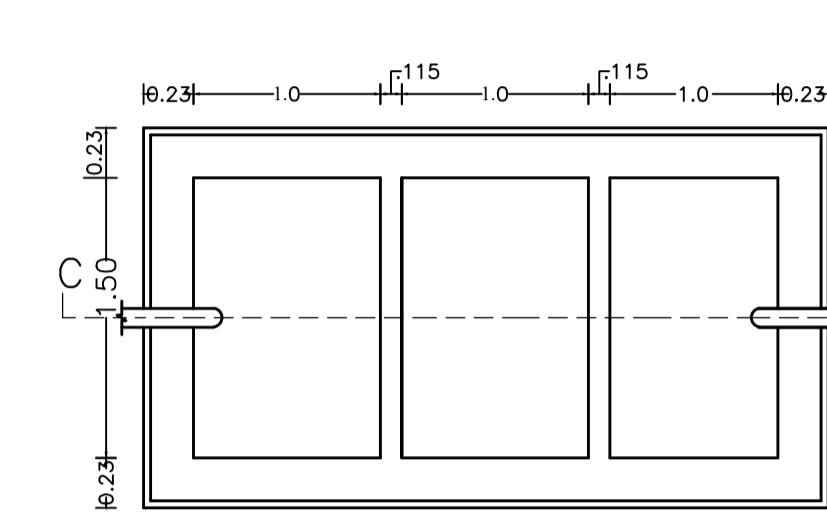

SEPTIC TANK PLAN
SCALE -1:50

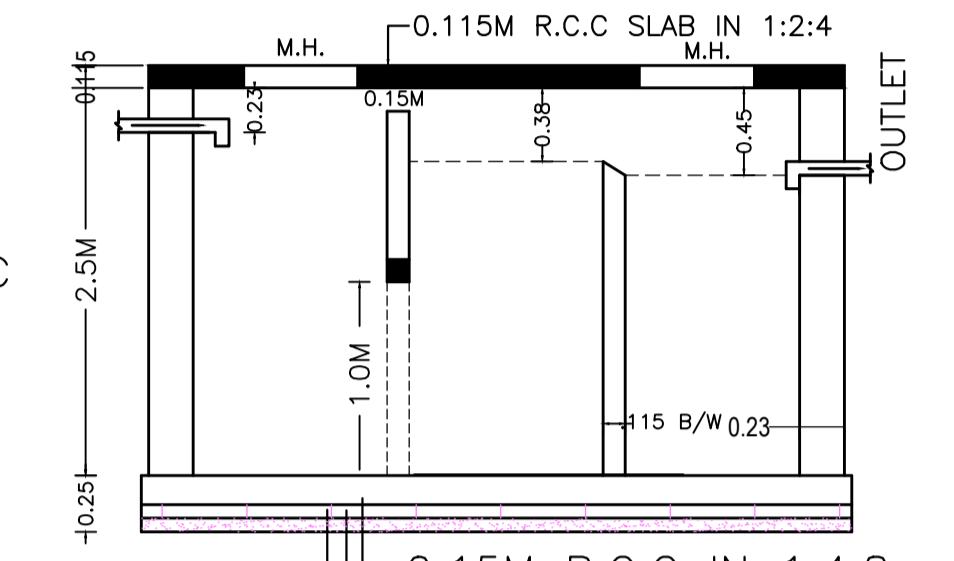

SECTION - SS
SCALE -1:50

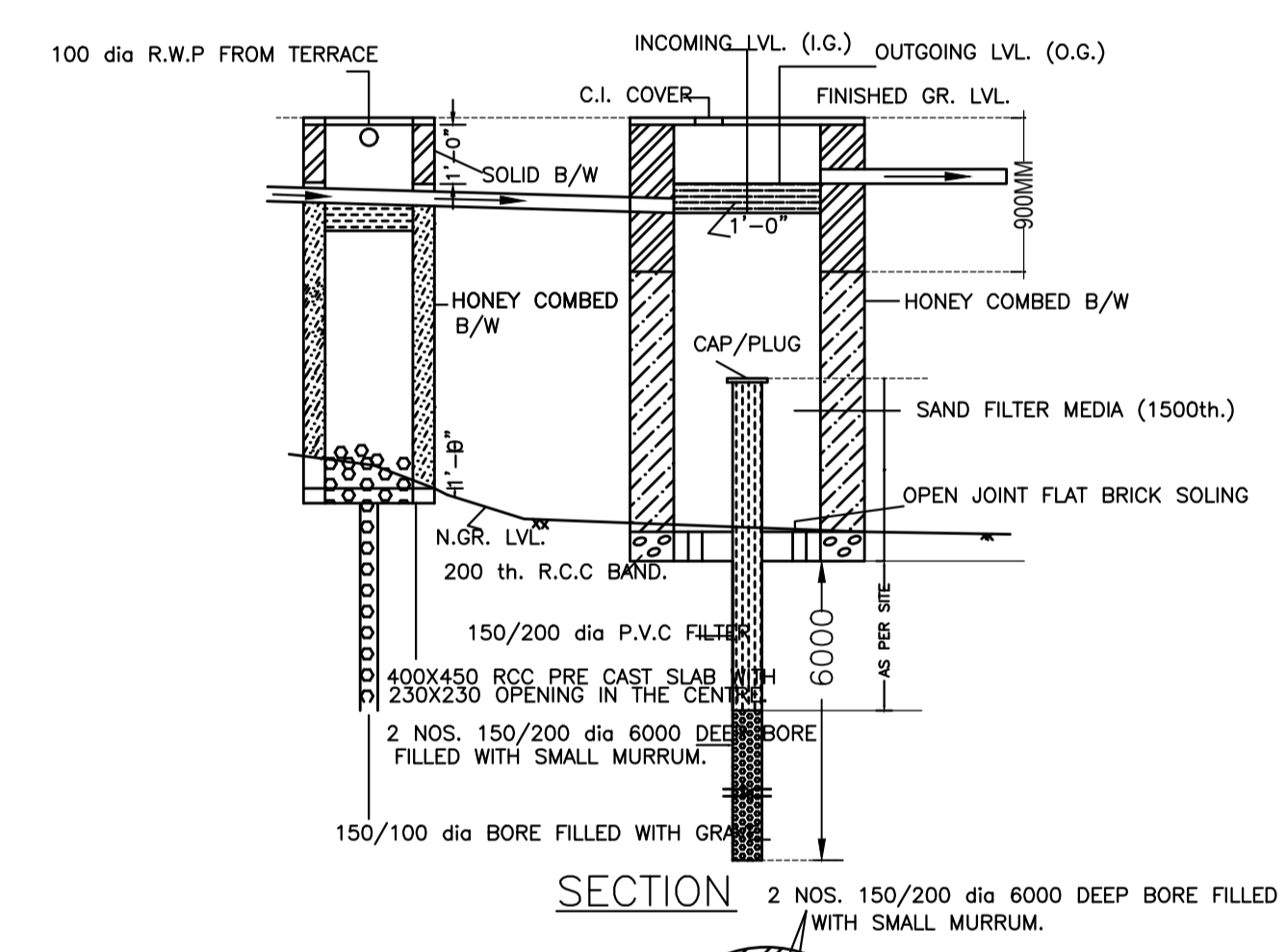

SECTION

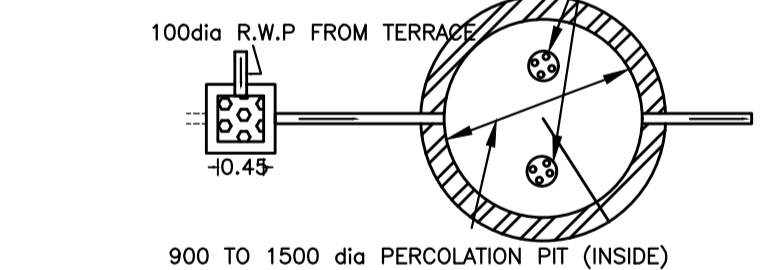

WATER HARVESTING PLAN (NTS)

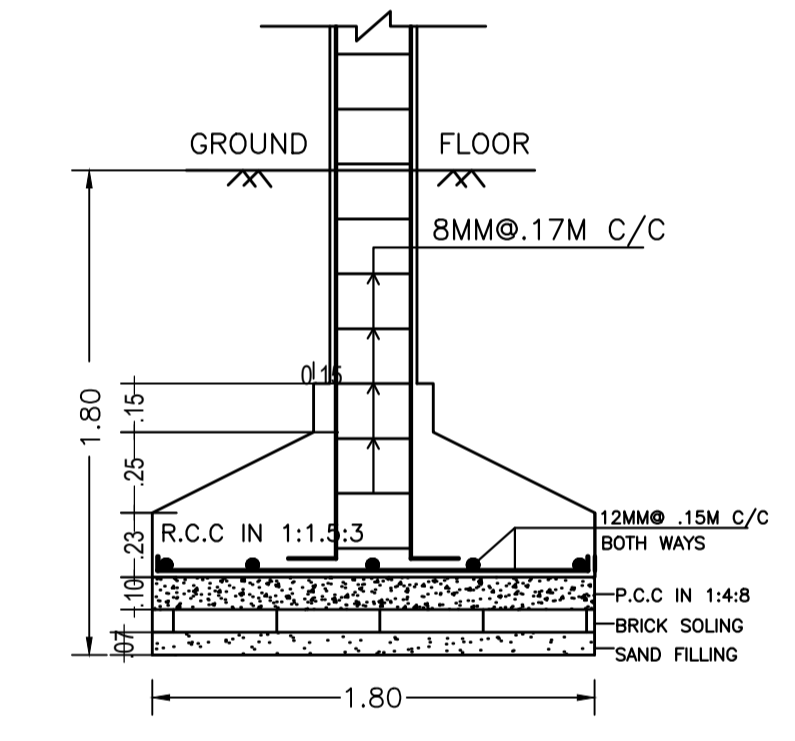

SECTION - CC
SCALE -1:25

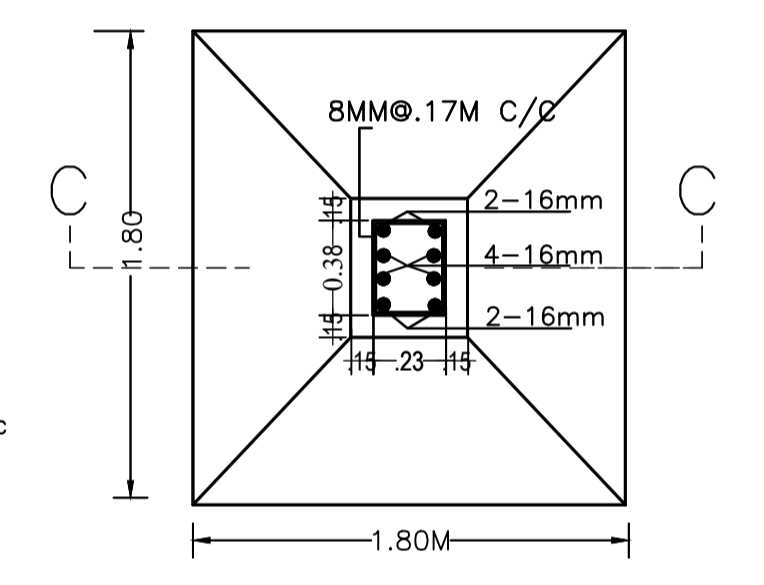

R.C.C. COL. FDN. PLAN
SCALE -1:25

LTP NAME AND SIGNATURE	STRUCTURAL ENG'S NAME AND SIGNATURE	BUILDER NAME AND SIGNATURE	DIGITAL SIGNATURE
EJAZ AHMAD MNAC/DFTMN/0008/2020			