

Project Title: MATIAS LAKRA

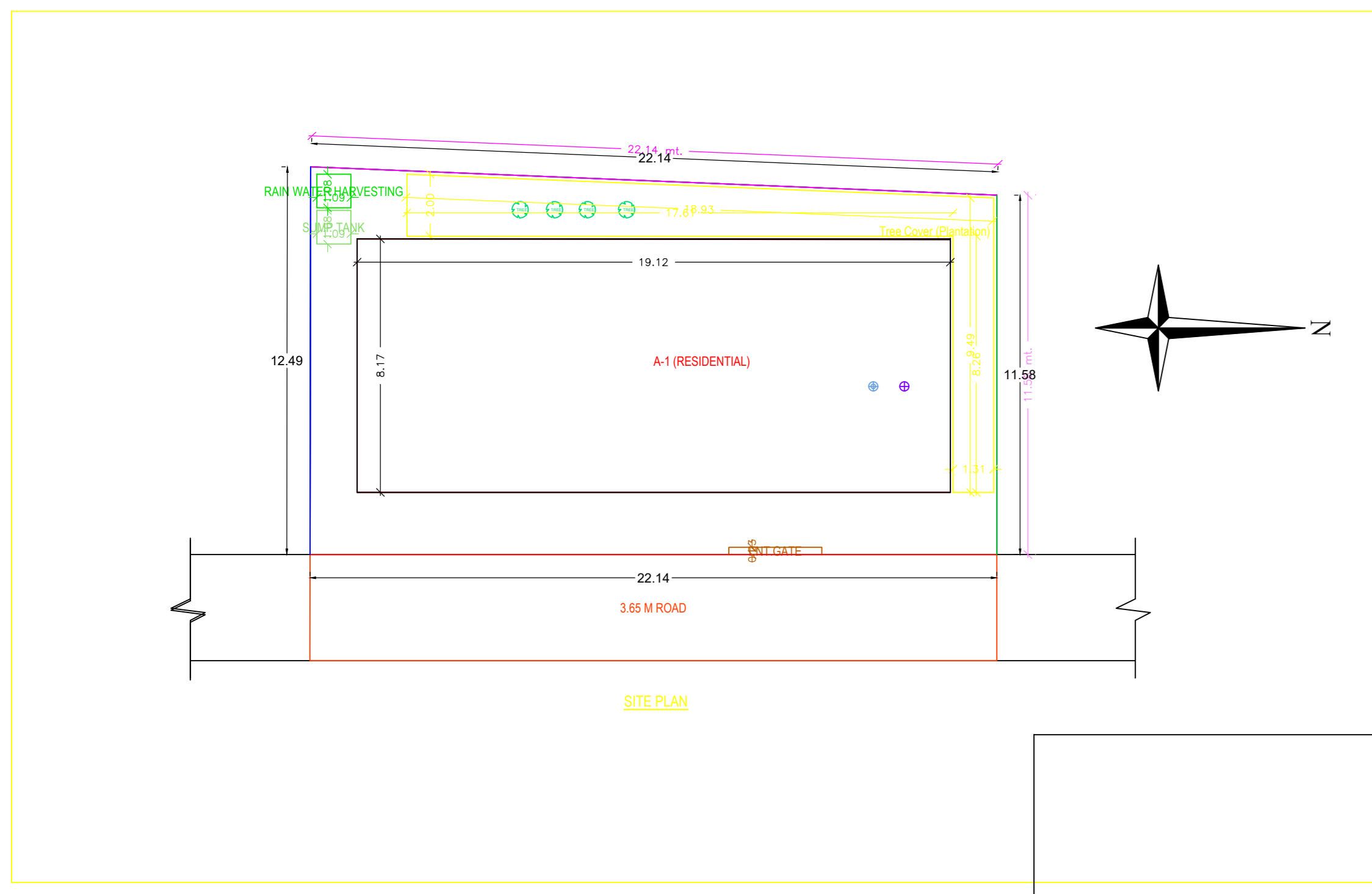
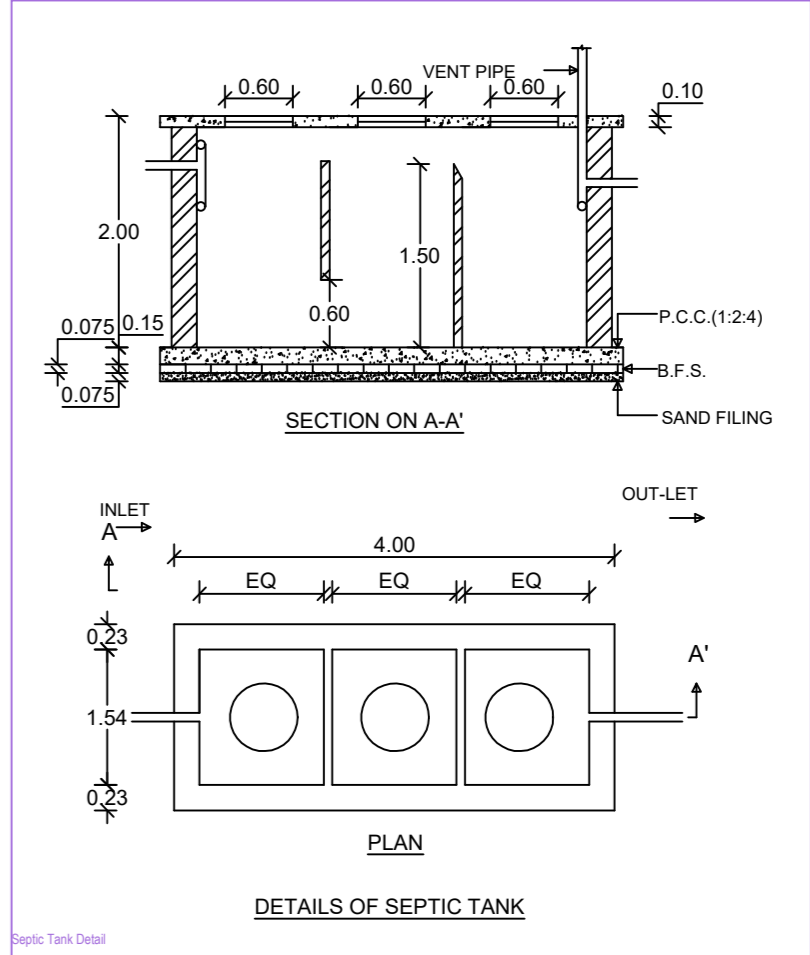
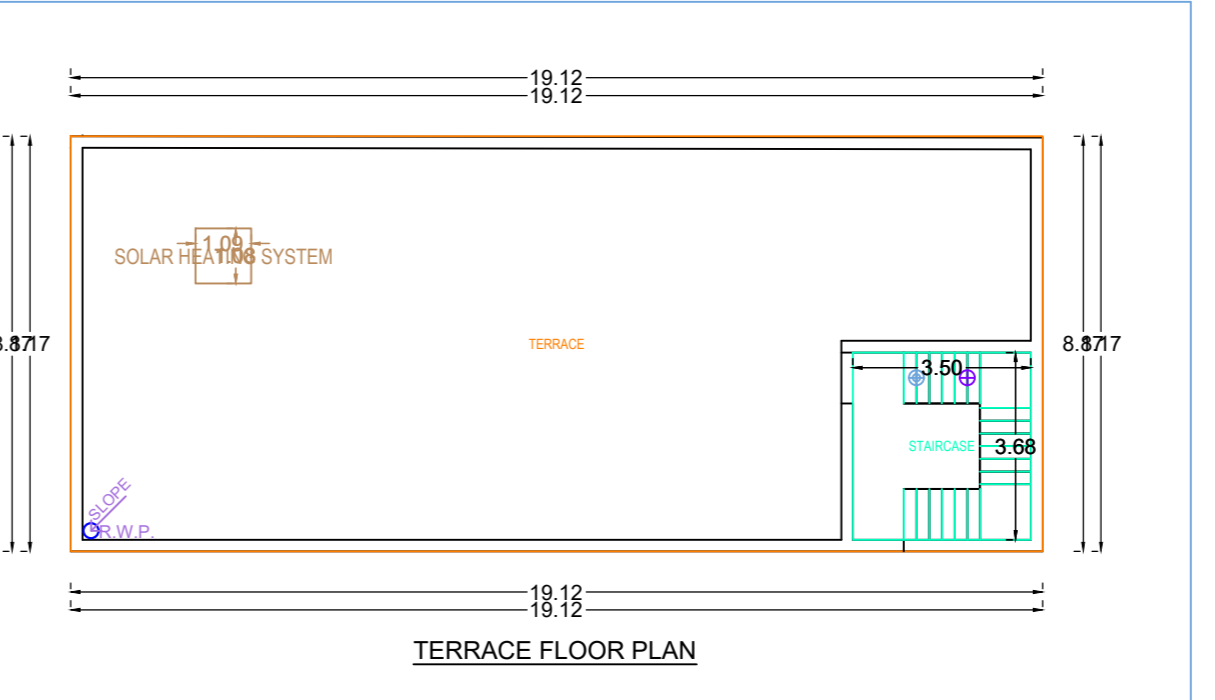
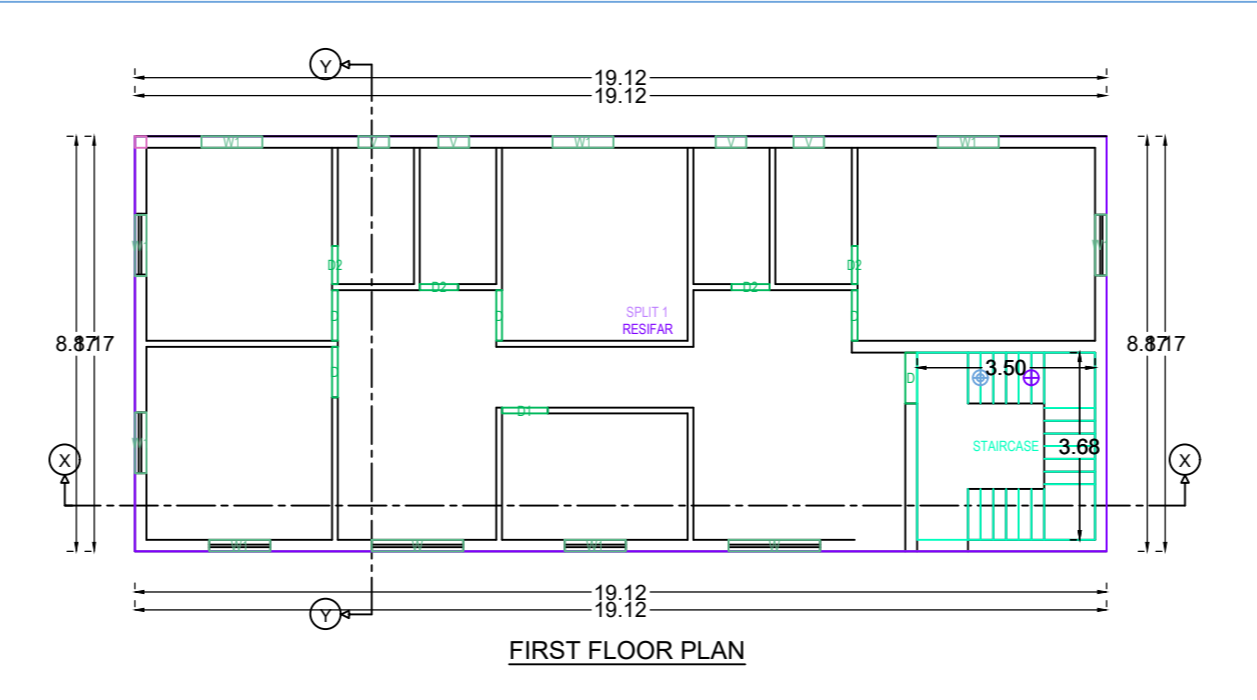
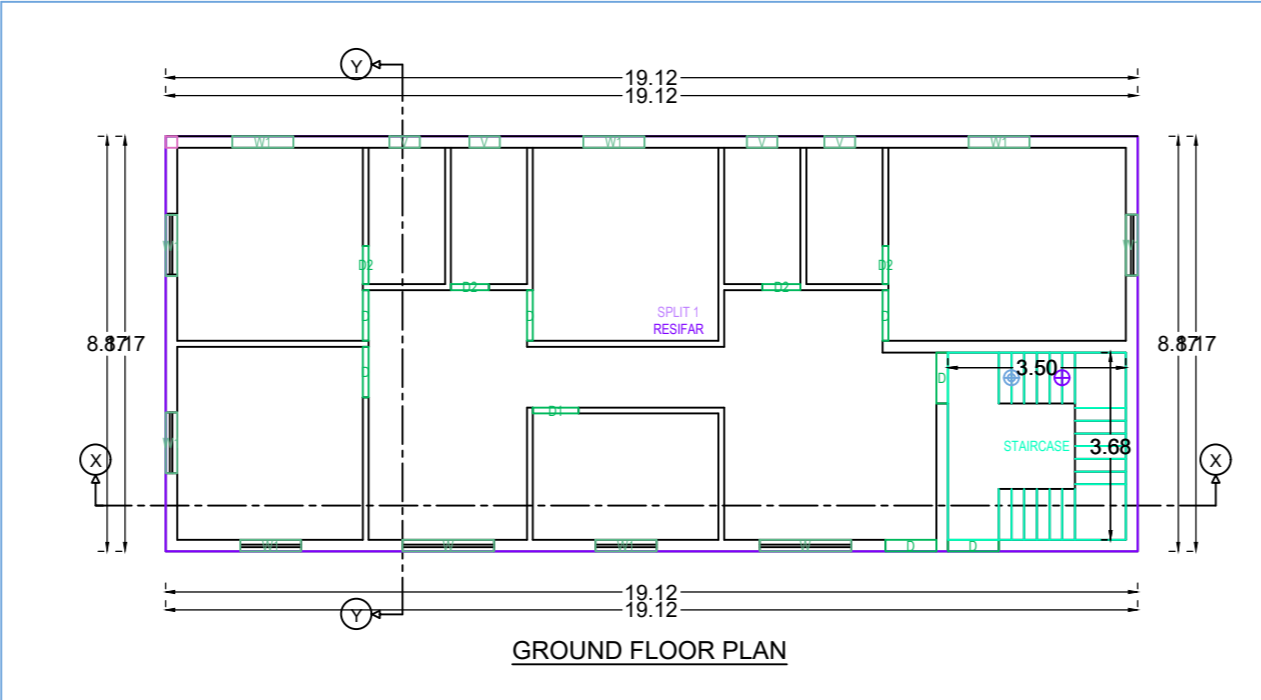
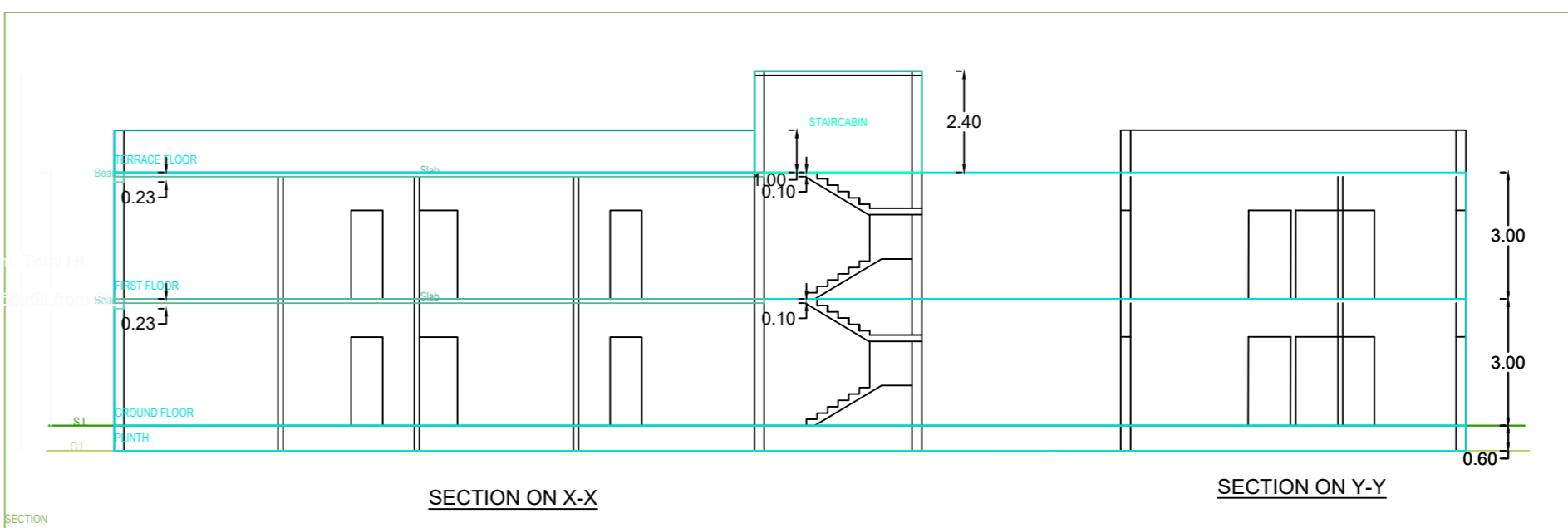
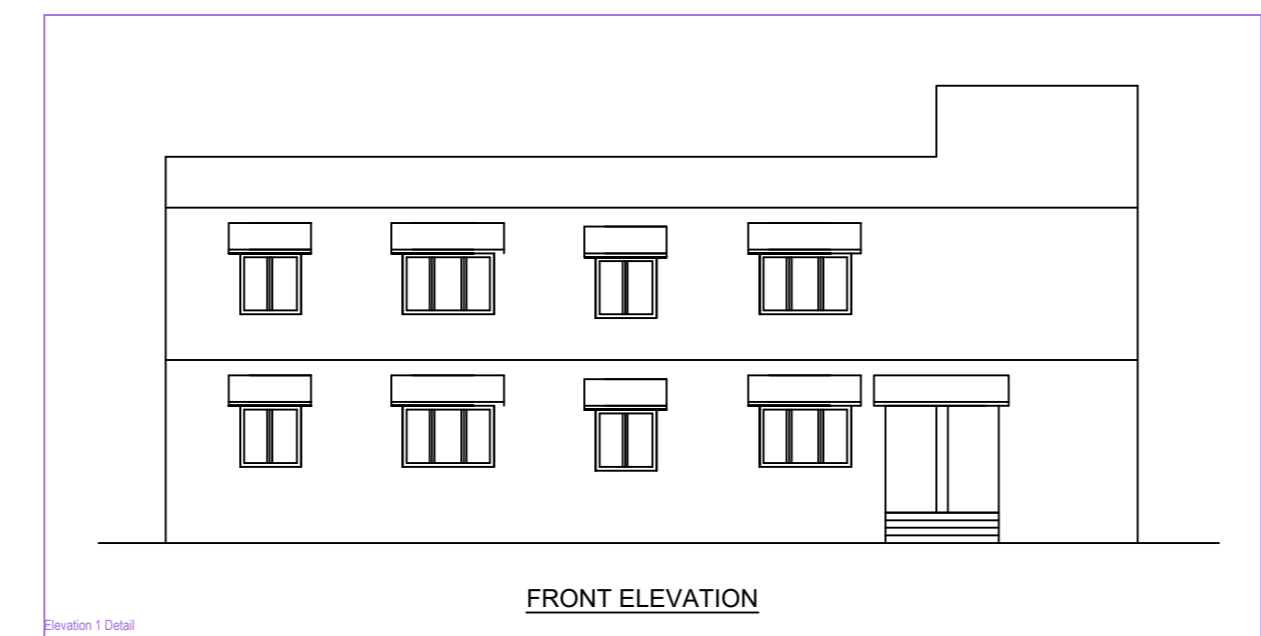
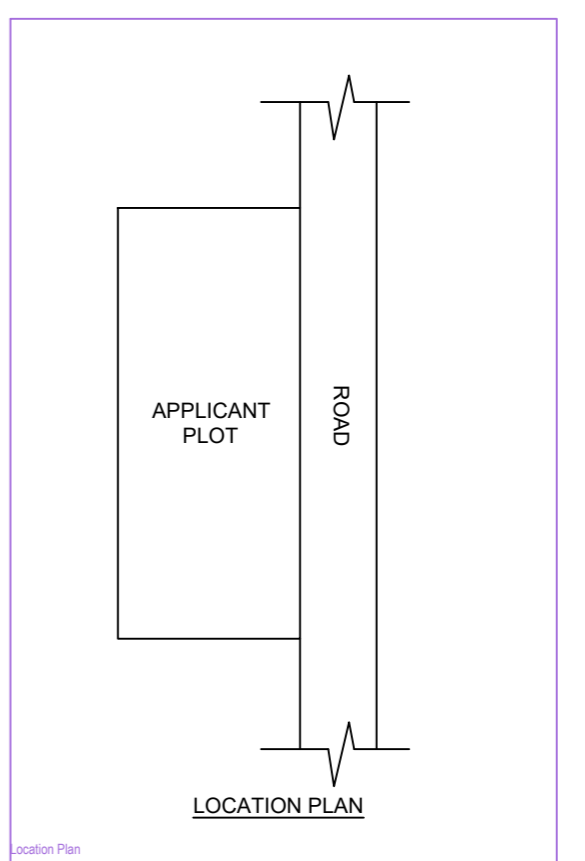
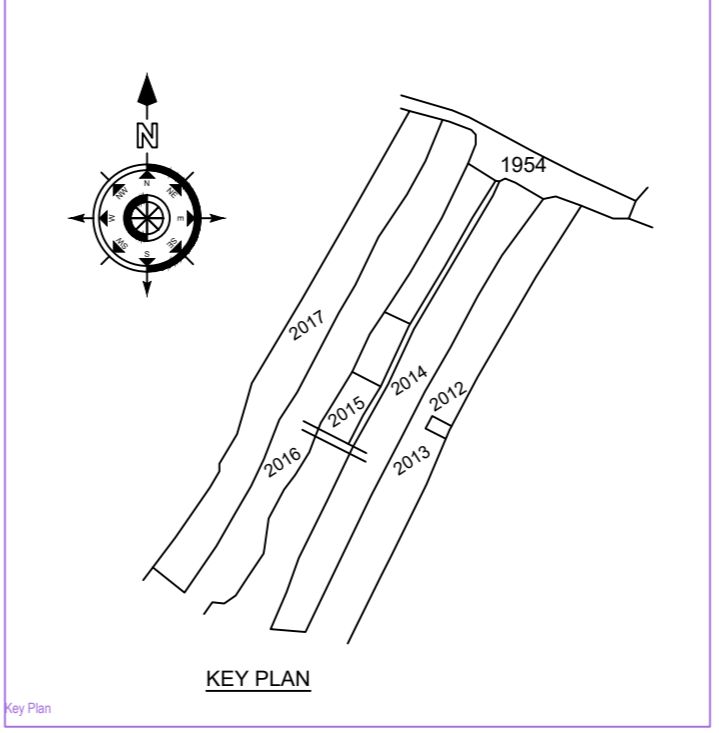
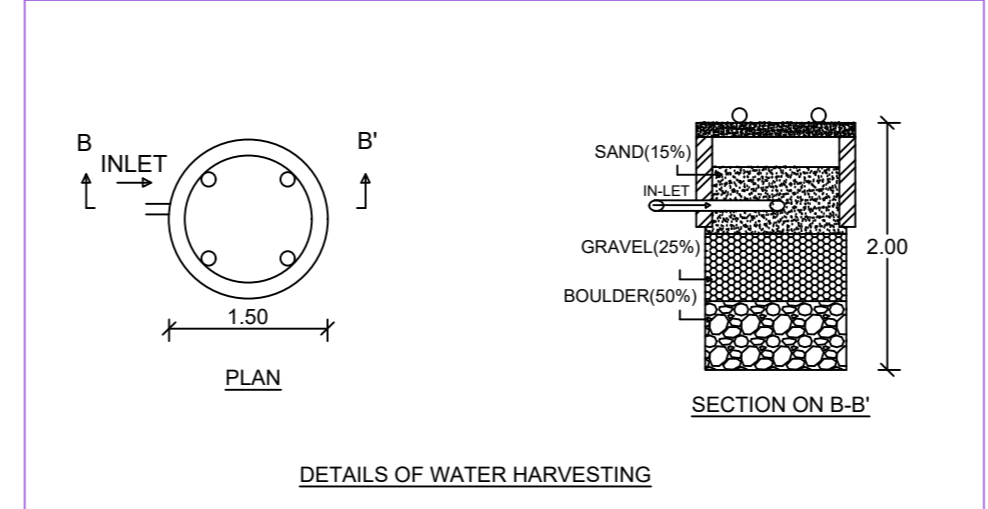
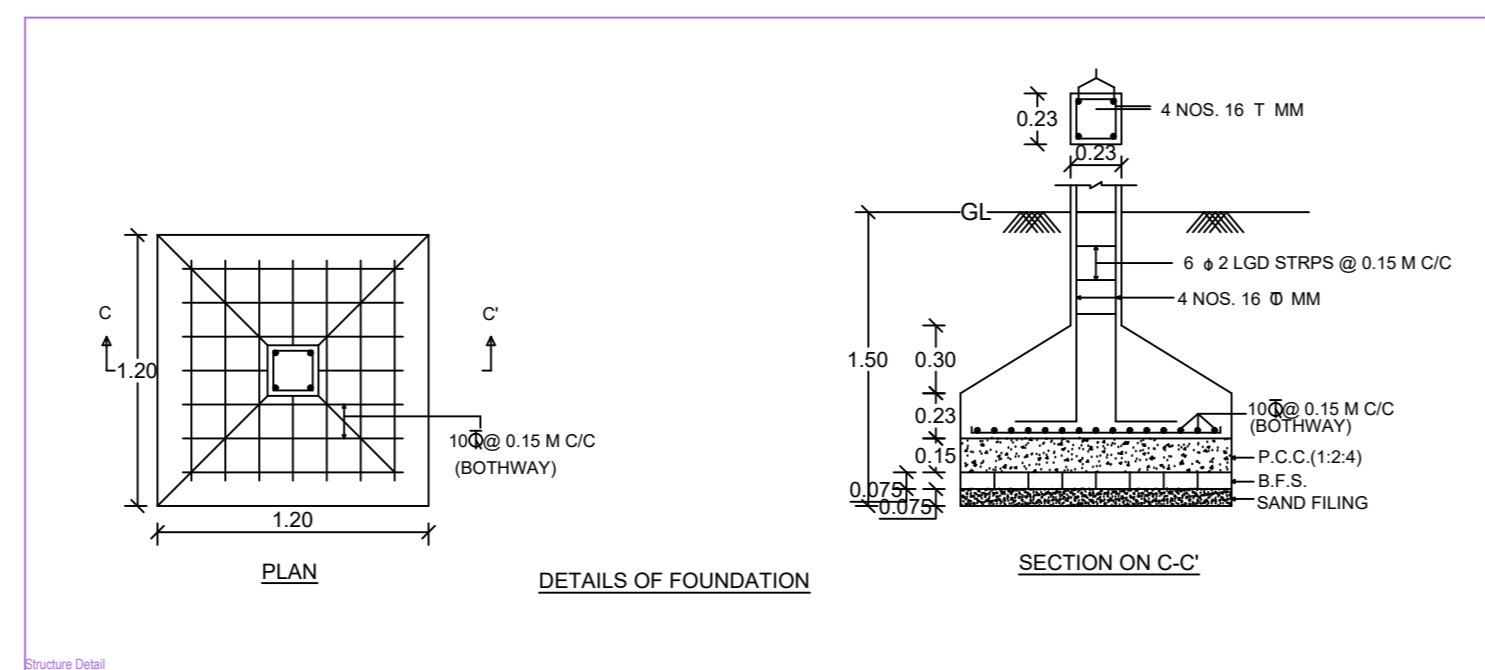

REVISION NO.	REVISION DATE	REVISION DESCRIPTION
01	10/10/2023	ISSUE FOR PERMIT

REVISION NO.	REVISION DATE	REVISION DESCRIPTION
02	10/10/2023	ISSUE FOR PERMIT

REVISION NO.	REVISION DATE	REVISION DESCRIPTION
03	10/10/2023	ISSUE FOR PERMIT

REVISION NO.	REVISION DATE	REVISION DESCRIPTION
04	10/10/2023	ISSUE FOR PERMIT

REVISION NO.	REVISION DATE	REVISION DESCRIPTION
05	10/10/2023	ISSUE FOR PERMIT

REVISION NO.	REVISION DATE	REVISION DESCRIPTION
06	10/10/2023	ISSUE FOR PERMIT

REVISION NO.	REVISION DATE	REVISION DESCRIPTION
07	10/10/2023	ISSUE FOR PERMIT

REVISION NO.	REVISION DATE	REVISION DESCRIPTION
08	10/10/2023	ISSUE FOR PERMIT

REVISION NO.	REVISION DATE	REVISION DESCRIPTION
09	10/10/2023	ISSUE FOR PERMIT

REVISION NO.	REVISION DATE	REVISION DESCRIPTION
10	10/10/2023	ISSUE FOR PERMIT

REVISION NO.	REVISION DATE	REVISION DESCRIPTION
11	10/10/2023	ISSUE FOR PERMIT

REVISION NO.	REVISION DATE	REVISION DESCRIPTION
12	10/10/2023	ISSUE FOR PERMIT