

SITE PLAN

Building USE/SUBUSE Details

Building Name	Building Use	Building SubUse	Building Structure	Floor Name	Floor Use	Floor SubUse	FAR Name	FAR Use	FAR SubUse
A (BUILDING)	Residential	Bungalow/ Dwelling / Non Apartment	Non-Highrise	GROUND FLOOR PLAN	Residential	Bungalow/ Dwelling / Non Apartment	Residential FAR	Residential	Bungalow/ Dwelling / Non Apartment
				FIRST FLOOR PLAN	Residential	Bungalow/ Dwelling / Non Apartment	Residential FAR	Residential	Bungalow/ Dwelling / Non Apartment
				TERRACE FLOOR PLAN	Residential	Bungalow/ Dwelling / Non Apartment	-	-	-

Proposal Basic Information

Proposal File No.	MNAC/BP/0076/W10/2024
Owner Name	MR. SANJAY KUMAR BOSE AND MR. SOURAV KUMAR BOSE
Khata No	425
Plot No	1453 (PART) , DUPLEX NO. - 12
Village Name	Baliguma
Use	Residential
SubUse	Bungalow/ Dwelling / Non Apartment

AREA STATEMENT MANGO MUNICIPAL CORPORATION	VERSION NO.: 1.0.71	VERSION DATE: 16/10/2020
PROJECT DETAIL:		
Region: JHARKHAND URBAN LOCAL BODIES	Plot Use: Residential	
District: EAST SINGHBHUM	Plot SubUse: Bungalow/ Dwelling / Non Apartment	
Authority: MANGO MUNICIPAL CORPORATION	PlotNearbyReligiousStructure: NA	
Inward No: MNAC/BP/0076/W10/2024	Plot/SubPlot No: 1453 (PART) , DUPLEX NO. - 12	
Application Type: General Proposal	North: Plot No. - DUPLEX NO. - 11	
Project Type: Building Permission	South: Plot No. - DUPLEX NO. - 13	
Nature of Development: New	East: Plot No. - DUPLEX NO. - 9	
Location of Development Area: Old Area	West: Road Width - 6.1	
AREA DETAILS:		
AREA OF PLOT (Minimum)	(A)	89.19
NET AREA OF PLOT(Gross Plot Area - Deduction from Gross Plot area)	(A-Deductions)	89.19
Deduction for Balance Plot Area(from Gross Plot Area)		
Common Plot		10.11
Total		10.11
BALANCE AREA OF PLOT(Net Plot Area - Recreational/Amenity space)	(A-Deductions)	79.07
PLOT AREA FOR COVERAGE(Net Plot Area)	(A-Deductions)	89.19
Plot Area for FAR (Net Plot Area + Road Widening Area)	(A-Deductions)	89.19
COVERAGE CHECK		
Permissible Coverage area (70.00 %)		62.43
Proposed Coverage Area (53.29 %)		47.53
Total Prop. Coverage Area (53.29 %)		47.53
Balance coverage area (16.71 %)		14.90
FAR CHECK		
Perm. FAR Area (2.500)		222.98
Total Perm. FAR area		222.98
Residential FAR		95.13
Proposed FAR Area		95.13
Total Proposed FAR Area		95.13
Consumed FAR (Factor)		1.07
Balance FAR Area		127.85
BUILT UP AREA CHECK		
Total Proposed BuiltUp Area		95.13
ARCHITECT (Regd)	SATISH KUMAR	
ENGINEER (Regd)		
SUPERVISOR (Regd)		
OWNER (Regd)	MR. SANJAY KUMAR BOSE AND MR. SOURAV KUMAR BOSE	
DEVELOPMENT AUTHORITY	LOCAL BODY	

COLOR INDEX	
PLOT BOUNDARY	Black
ABUTTING ROAD	Green
PROPOSED CONSTRUCTION	Red
COMMON PLOT	Yellow
ROAD WIDENING AREA	Orange
EXISTING (To be retained)	Blue
EXISTING (To be demolished)	Light Blue

Buildingwise Floor FAR Details

Floor Name	Building Name		Total	
	Proposed Built Up Area (Sq.mt.)	Proposed FAR Area (Sq.mt.)	Total Proposed Built Up Area (Sq.mt.)	Total FAR Area (Sq.mt.)
Ground Floor	47.53	47.53	47.53	47.53
First Floor	47.60	47.60	47.60	47.60
Terrace Floor	0.00	0.00	0.00	0.00
Total :	95.13	95.13	95.13	95.13

FAR & Tenement Details (Table 4c-1)

Building	No. of Same Bldg	Total Built Up Area (Sq.mt.)	Proposed FAR Area (Sq.mt.)	Total FAR Area (Sq.mt.)	Total Consumed Additional FAR Area (Sq.mt.)	Tnmt (No.)
A (BUILDING)	1	95.13	95.13	95.13	95.13	01
Grand Total :	1	95.13	95.13	95.13	95.13	01

LTP NAME AND SIGNATURE	STRUCTURAL ENG'S NAME AND SIGNATURE	BUILDER NAME AND SIGNATURE	DIGITAL SIGNATURE
SATISH KUMAR MNAC/DFTMN/0001/2017			

Proposal Basic Information

Proposal File No.	MNAC/BI/0076/W10/2024
Owner Name	MR. SANJAY KUMAR BOSE AND MR. SOURAV KUMAR
Khata No	425
Plot No	1453 (PART) , DUPLEX NO. - 12
Village Name	Baliguma
Use	Residential
SubUse	Bungalow/ Dwelling / Non Apartment

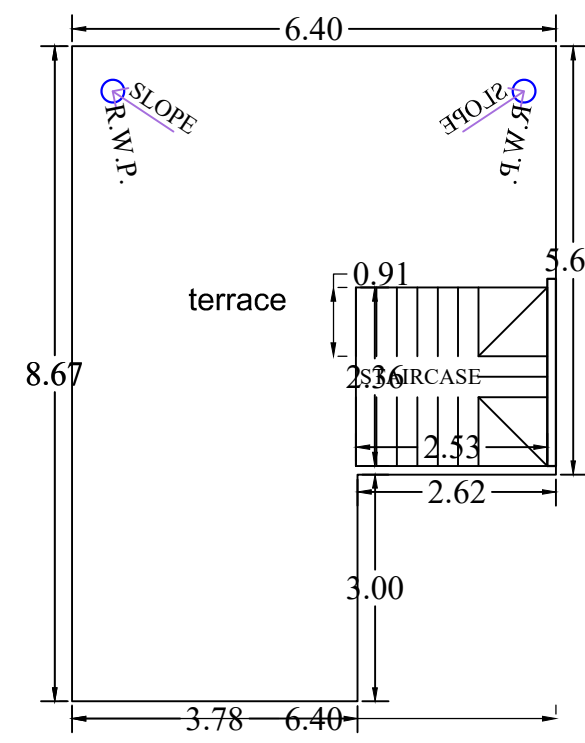
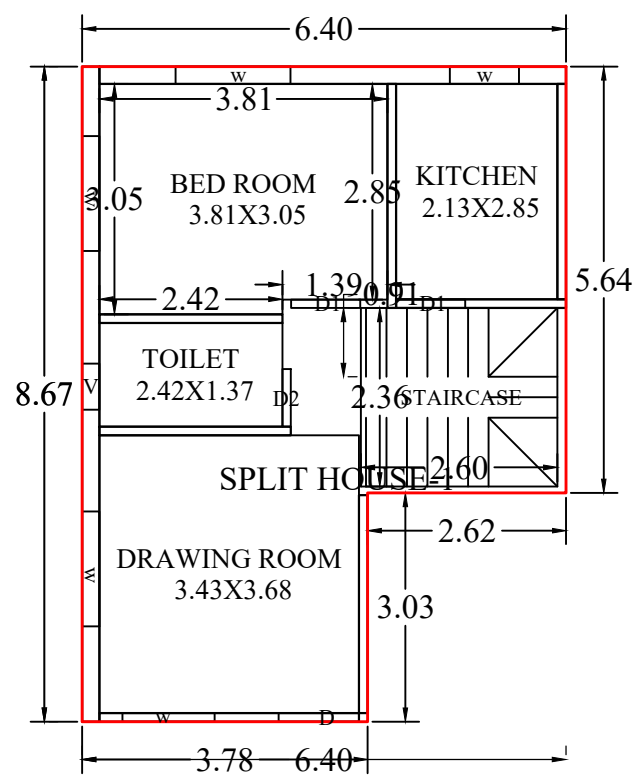

TERRACE FLOOR PLAN (SCALE 1:100)

GROUND FLOOR PLAN (Proposed) (SCALE 1:100)

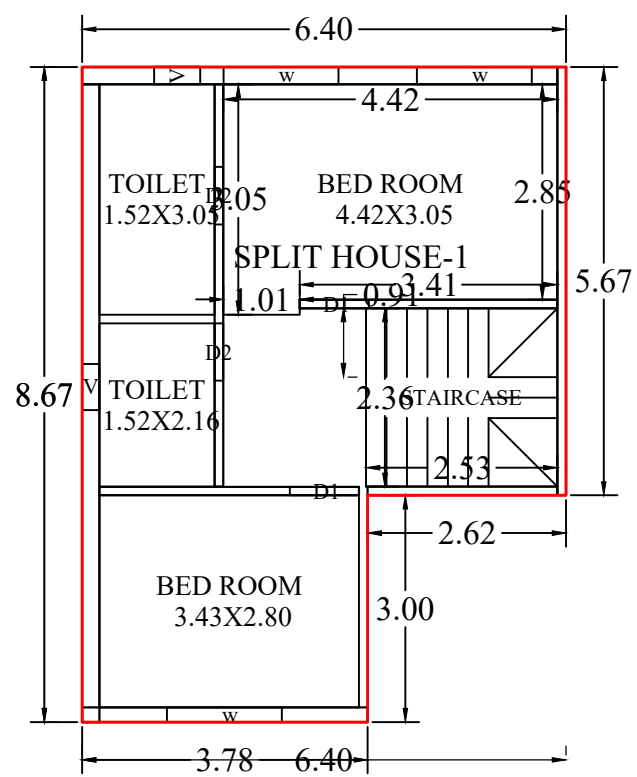

FIRST FLOOR PLAN (Proposed) (SCALE 1:100)

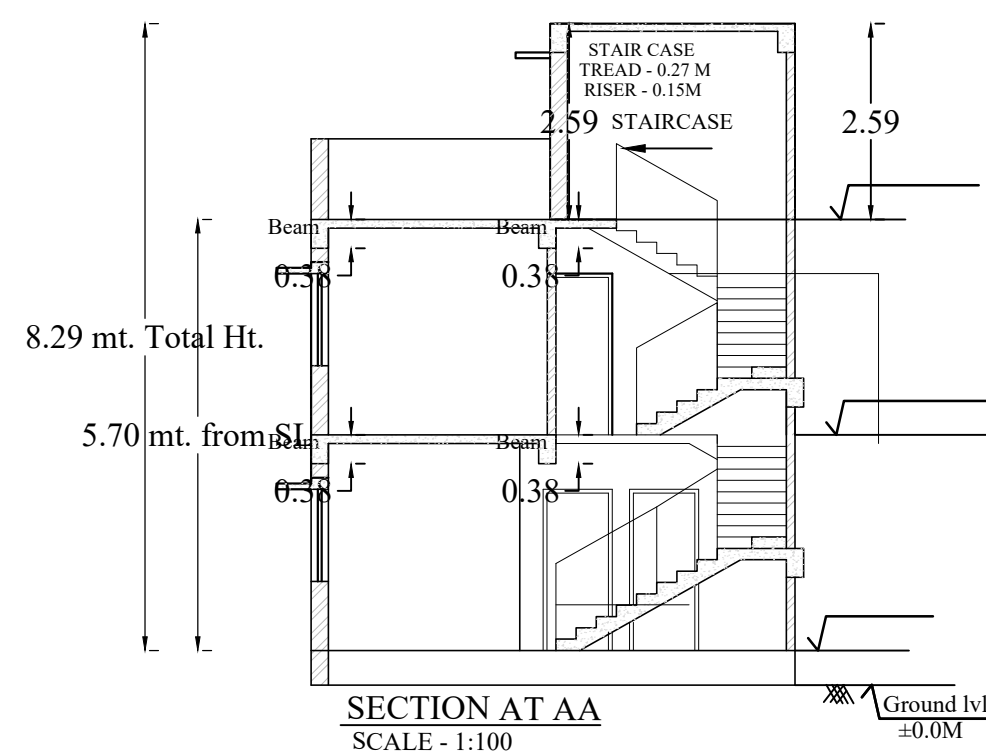

SECTION AT AA SCALE - 1:100

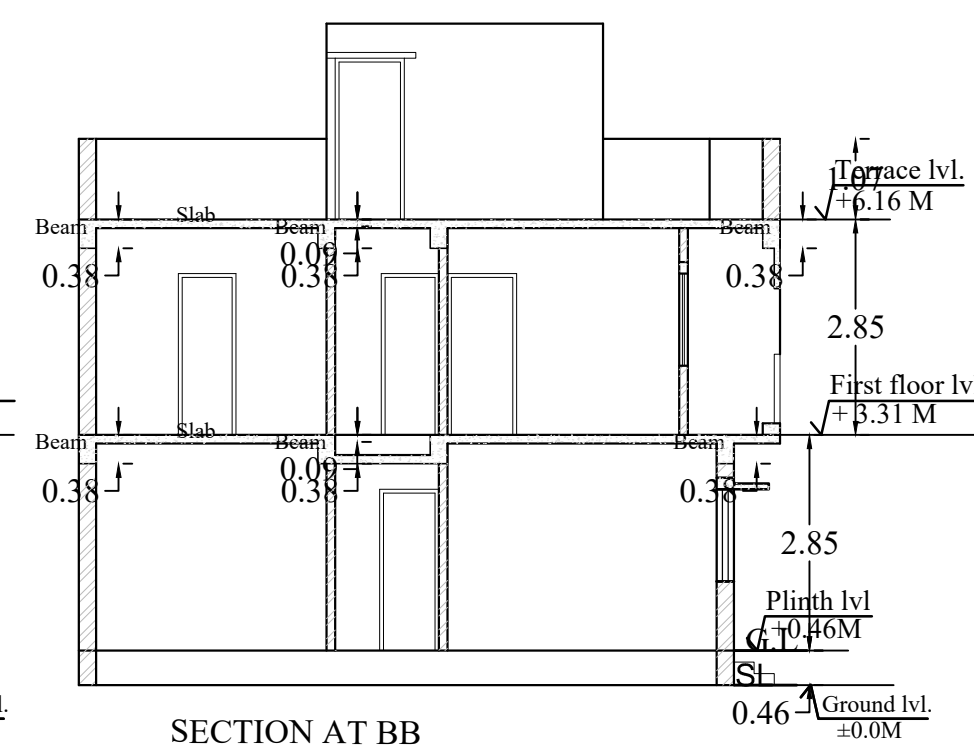

SECTION AT BB SCALE - 1:100

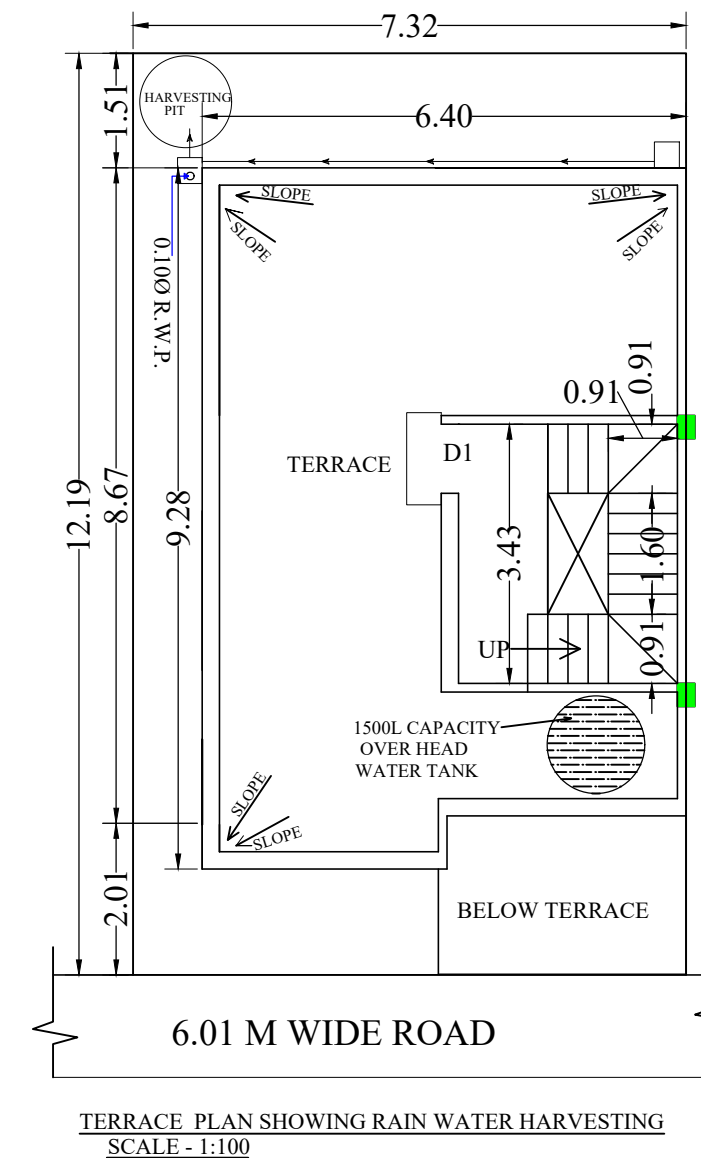

TERRACE PLAN SHOWING RAIN WATER HARVESTING SCALE - 1:100

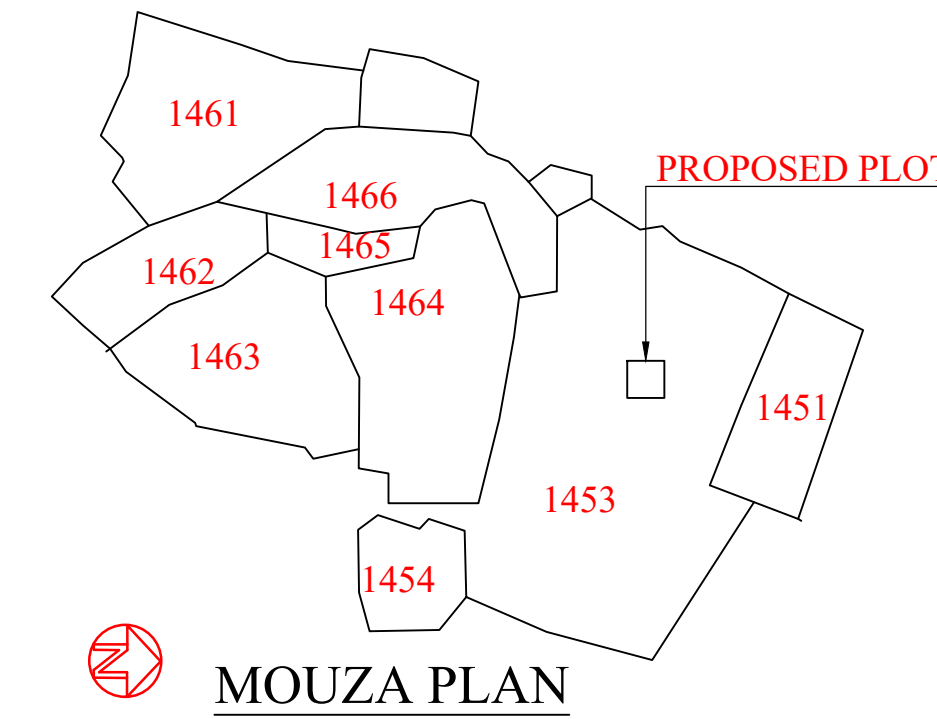

MOUZA PLAN

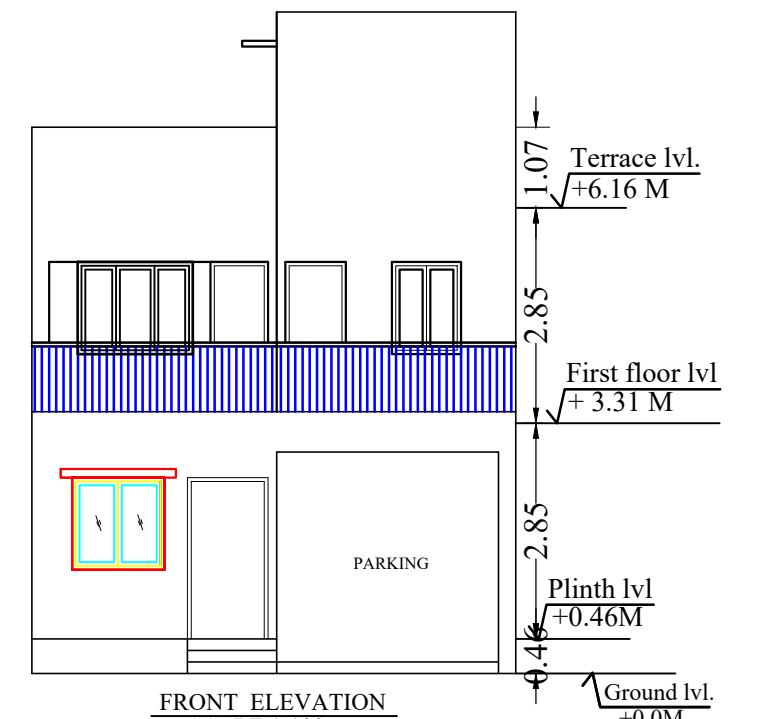

FRONT ELEVATION SCALE 1:100

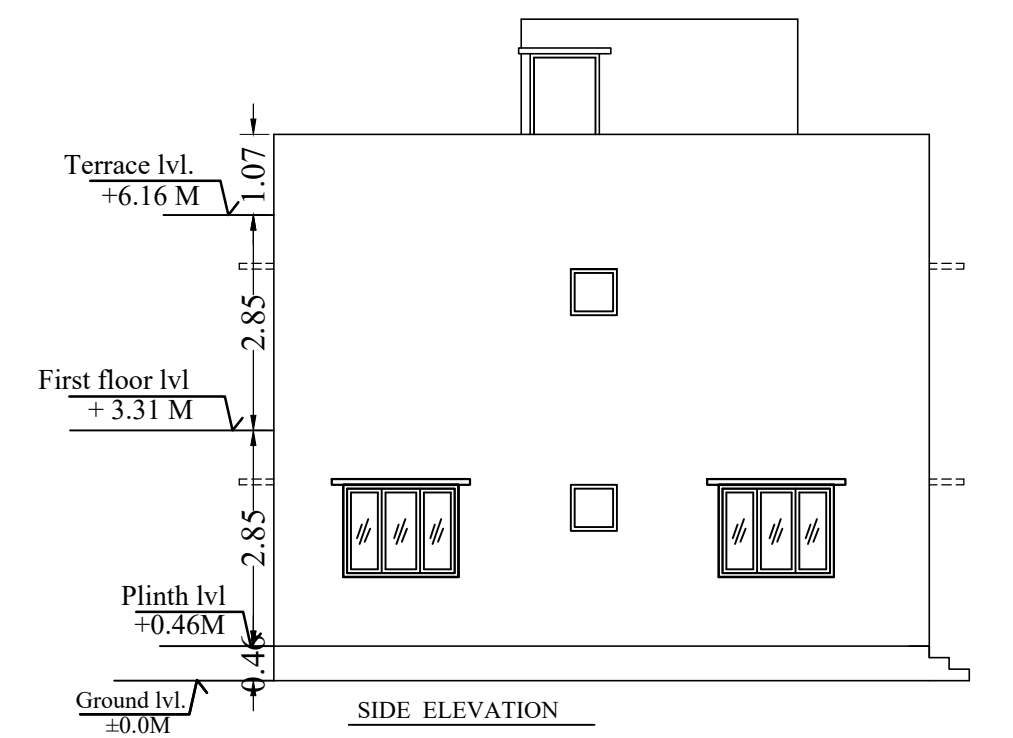

SIDE ELEVATION

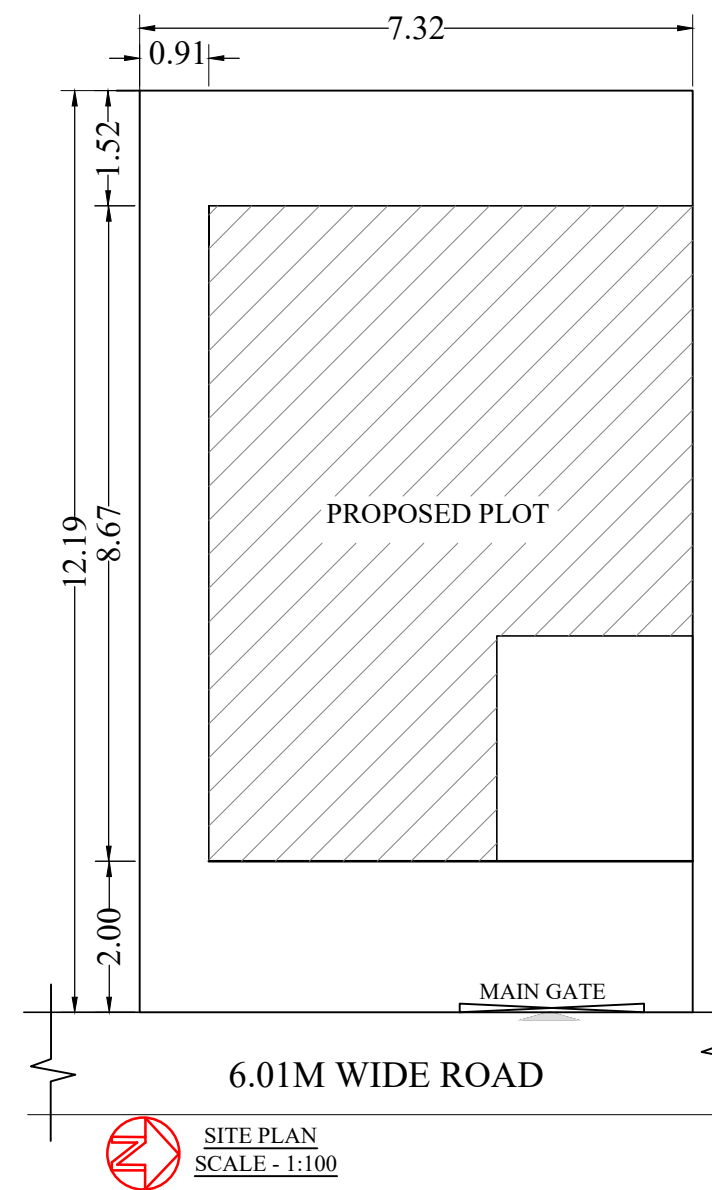

SITE PLAN SCALE - 1:100

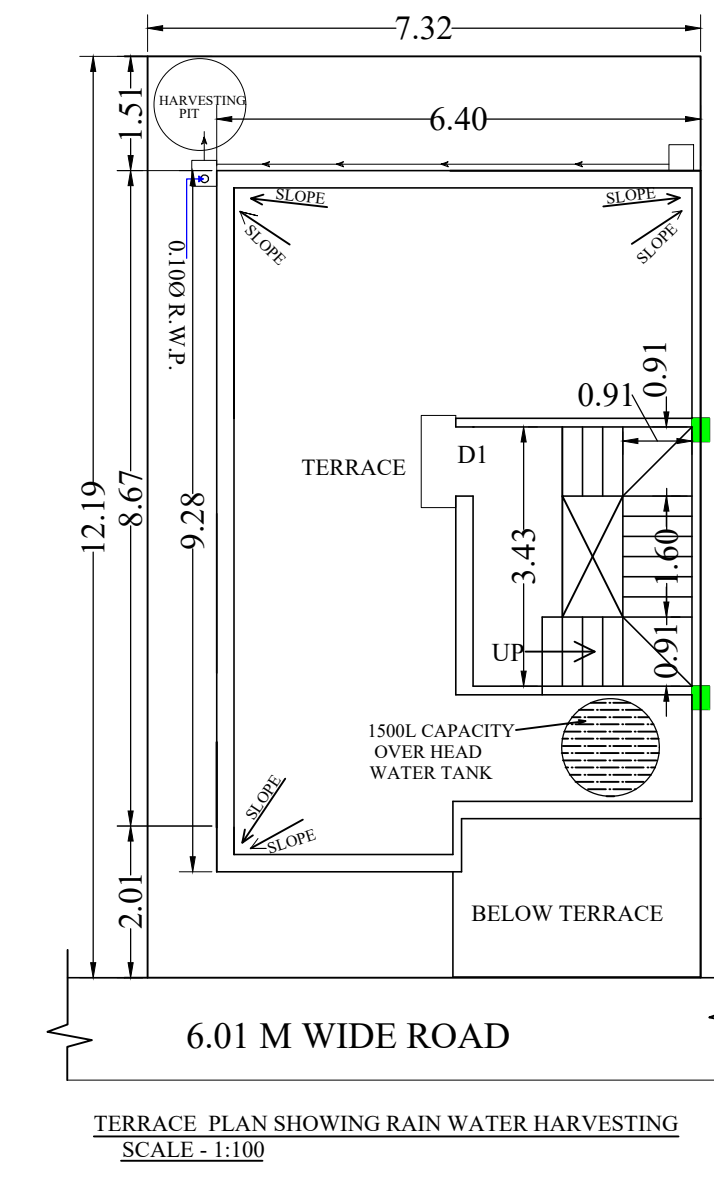

TERRACE PLAN SHOWING RAIN WATER HARVESTING SCALE - 1:100

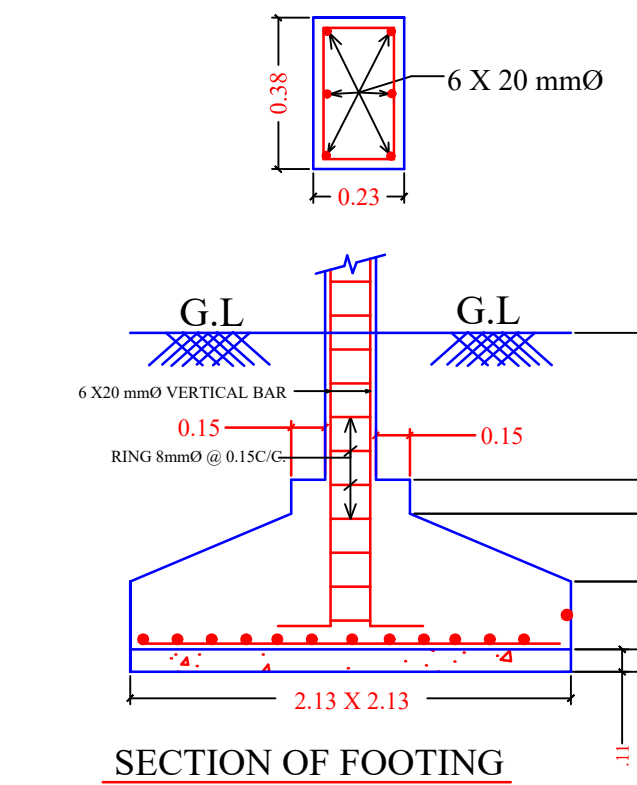

SECTION OF FOOTING

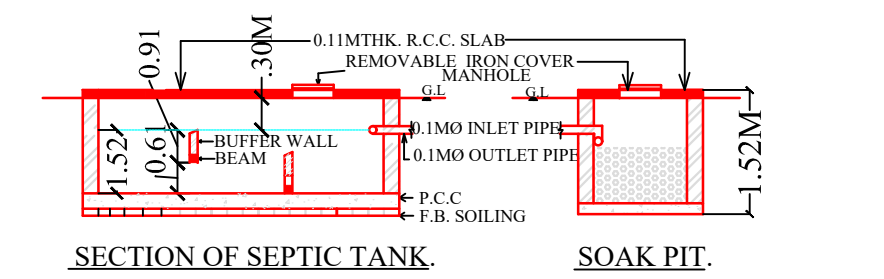

SECTION OF SEPTIC TANK

SOAK PIT

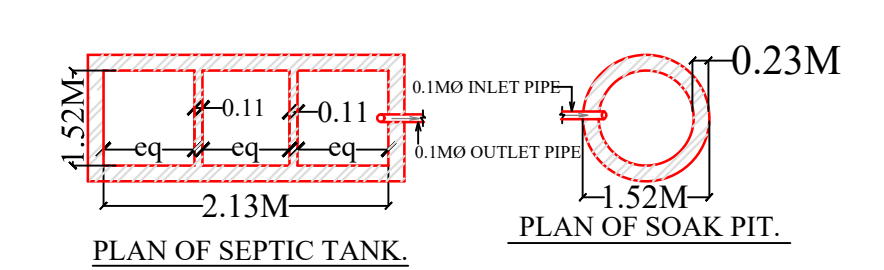

PLAN OF SEPTIC TANK

PLAN OF SOAK PIT

Building :A (BUILDING)

Floor Name	Total Built Up Area (Sq.mt.)	Proposed FAR Area (Sq.mt.) Resi.	Total FAR Area (Sq.mt.)	Total Consumed Additional FAR Area (Sq.mt.)	Tnmt (No.)
Ground Floor	47.53	47.53	47.53	47.53	01
First Floor	47.60	47.60	47.60	47.60	00
Terrace Floor	0.00	0.00	0.00	0.00	00
Total:	95.13	95.13	95.13	95.13	01
Total Number of Same Buildings	1				
Total:	95.13	95.13	95.13	95.13	01

SCHEDULE OF DOOR:

BUILDING NAME	NAME	LENGTH	HEIGHT	NOS
A (BUILDING)	D2	0.76	2.13	03
A (BUILDING)	D1	0.91	2.13	04
A (BUILDING)	D	1.06	2.13	01

SCHEDULE OF WINDOW/VENTILATION:

BUILDING NAME	NAME	LENGTH	HEIGHT	NOS
A (BUILDING)	v	0.61	0.61	03
A (BUILDING)	w	0.91	1.22	01
A (BUILDING)	w	1.22	1.22	01
A (BUILDING)	w	1.52	1.22	06

UnitBUA Table for Building :A (BUILDING)

FLOOR	Name	UnitBUA Type	UnitBUA Area	Carpet Area	No. of Rooms	No. of Tenement
GROUND FLOOR PLAN	SPLIT HOUSE-1	FLAT	95.13	83.11	4	1
FIRST FLOOR PLAN	SPLIT HOUSE-1	FLAT	0.00	0.00	4	0
Total:	-	-	95.13	83.11	8	1

LTP NAME AND SIGNATURE	STRUCTURAL ENG'S NAME AND SIGNATURE	BUILDER NAME AND SIGNATURE	DIGITAL SIGNATURE
SATISH KUMAR MNAC/DFT/MN/0001/2017			