

SITE PLAN
SCALE 1:100

SITE PLAN

FAR & Tenement Details (Table 4c-1)

Building	No. of Same Bldg	Gross Built Up Area (Sq.mt.)	Deductions From Gross BUA/Area in Sq.mt. Cutout	Total Built Up Area (Sq.mt.)	Deductions (Area in Sq.mt.) Parking	Proposed FAR Area (Sq.mt.) Resi.	Total FAR Area (Sq.mt.)	Total Consumed Additional FAR Area (Sq.mt.)	Tnmt (No.)
A (MRS PUJA WO MR RAJIV DAS)	1	139.87	1.88	137.99	35.90	102.09	102.09	102.09	01
Grand Total	1	139.87	1.88	137.99	35.90	102.09	102.09	102.09	01

Proposal Basic Information

Proposal File No.	MNAC/BP/0084/W09/2024
Owner Name	MRS PUJA W.O MR RAJIV DAS
Khata No	422
Plot No	1819
Village Name	Dimna
Use	Residential
SubUse	Bungalow/ Dwelling / Non Apartment

Building USE/SUBUSE Details

Building Name	Building Use	Building SubUse	Building Structure	Floor Name	Floor Use	Floor SubUse	FAR Name	FAR Use	FAR SubUse
A (MRS PUJA WO MR RAJIV DAS)	Residential	Bungalow/ Dwelling / Non Apartment	Non-Highrise	FIRST FLOOR PLAN	Residential	Bungalow/ Dwelling / Non Apartment	Residential FAR	Residential	Bungalow/ Dwelling / Non Apartment
				TERRACE FLOOR PLAN	Residential	Bungalow/ Dwelling / Non Apartment	-	-	-
				GROUND FLOOR PLAN	Residential	Bungalow/ Dwelling / Non Apartment	Residential FAR	Residential	Bungalow/ Dwelling / Non Apartment

AREA STATEMENT MANGO MUNICIPAL CORPORATION		VERSION NO. 1.0.71
		VERSION DATE: 16/10/2020
PROJECT DETAIL:		
Region: JHARKHAND URBAN LOCAL BODIES	Plot Use: Residential	
District: EAST SINGHBHUM	Plot SubUse: Bungalow/ Dwelling / Non Apartment	
Authority: MANGO MUNICIPAL CORPORATION	PlotNearby/ReligiousStructure: NA	
Inward No: MNAC/BP/0084/W09/2024	Plot/SubPlot No: 1819	
Application Type: General Proposal	North: Plot No. - 1819	
Project Type: Building Permission	South: Plot No. - 1819	
Nature of Development: New	East: Road Width - 3.35	
Location of Development Area: Old Area	West: Plot No. - 1819	
AREA DETAILS:		
AREA OF PLOT (Minimum)	(A)	SQ.MT. 116.99
Deduction for NetPlot Area		
Reservation Area		1.37
Total		1.37
NET AREA OF PLOT(Gross Plot Area - Deduction from Gross Plot area)	(A-Deductions)	115.62
Deduction for Balance Plot Area(from Gross Plot Area)		
Reservation Area		1.37
Common Plot		13.86
Total		15.23
BALANCE AREA OF PLOT (Net Plot Area - Recreational/Amenity space)	(A-Deductions)	101.76
PLOT AREA FOR COVERAGE(Net Plot Area)	(A-Deductions)	115.62
Plot Area for FAR (Net Plot Area + RoadWidening Area)	(A-Deductions)	115.62
COVERAGE CHECK		
Permissible Coverage area (70.00 %)		80.93
Proposed Coverage Area (62.12 %)		71.82
Total Prop. Coverage Area (62.12 %)		71.82
Balance coverage area (7.88 %)		9.11
FAR CHECK		
Perm. FAR Area (1.200)		138.74
Total Perm. FAR area		138.74
Residential FAR		102.09
Proposed FAR Area		102.09
Total Proposed FAR Area		102.09
Consumed FAR (Factor)		0.88
Balance FAR Area		36.65
BUILT UP AREA CHECK		
Total Proposed BuiltUp Area		137.99
ARCHITECT (Regd)	Chandrika Sharma	
ENGINEER (Regd)		
SUPERVISOR (Regd)		
OWNER (Regd)	MRS PUJA W.O MR RAJIV DAS	
DEVELOPMENT AUTHORITY		LOCAL BODY

COLOR INDEX	
PLOT BOUNDARY	Black
ABUTTING ROAD	Green
PROPOSED CONSTRUCTION	Red
COMMON PLOT	Yellow
ROAD WIDENING AREA	Blue
EXISTING (To be retained)	Orange
EXISTING (To be demolished)	Light Blue

Buildingwise Floor FAR Details

Floor Name	Building Name		Total	
	A (MRS PUJA WO MR RAJIV DAS) Proposed Built Up Area (Sq.mt.)	Proposed FAR Area (Sq.mt.)	Total Proposed Built Up Area (Sq.mt.)	Total FAR Area (Sq.mt.)
Ground Floor	71.83	35.93	71.83	35.93
First Floor	66.16	66.16	66.16	66.16
Terrace Floor	0.00	0.00	0.00	0.00
Total	137.99	102.09	137.99	102.09

LTP NAME AND SIGNATURE	STRUCTURAL ENG'S NAME AND SIGNATURE	BUILDER NAME AND SIGNATURE	DIGITAL SIGNATURE
Chandrika Sharma MNAC/DFTMN/0017/2017			

Proposal Basic Information	
Proposal File No.	MNAC/BI/0084/W09/2024
Owner Name	MRS PUJA W.O MR RAJIV DAS
Khata No	422
Plot No	1819
Village Name	Dimna
Use	Residential
SubUse	Bungalow/ Dwelling / Non Apartment

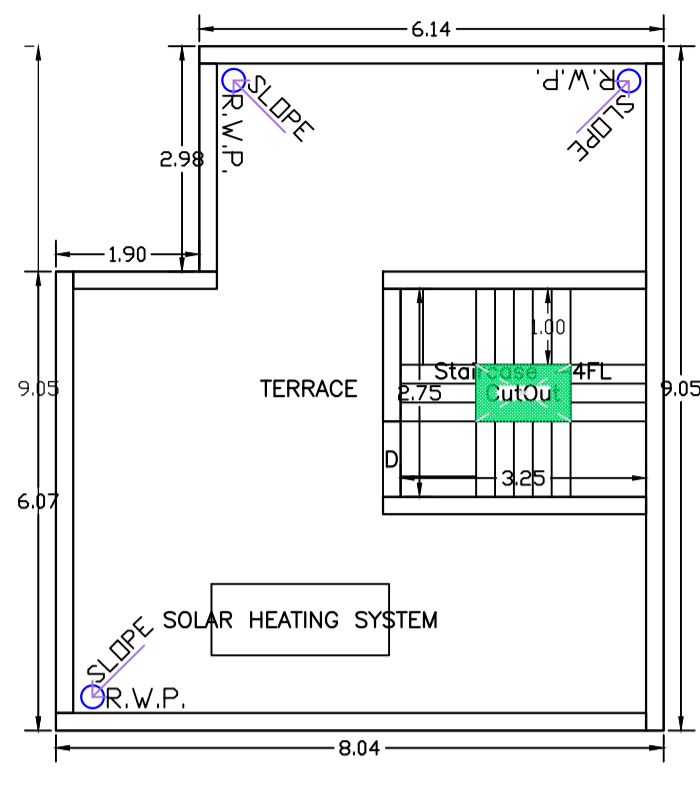
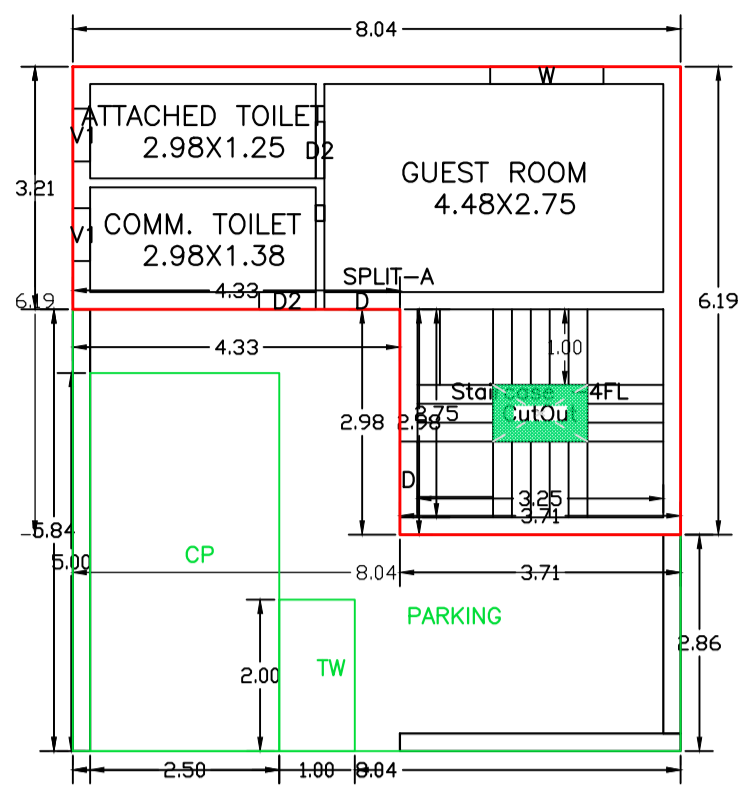

TERRACE FLOOR PLAN (SCALE 1:100)

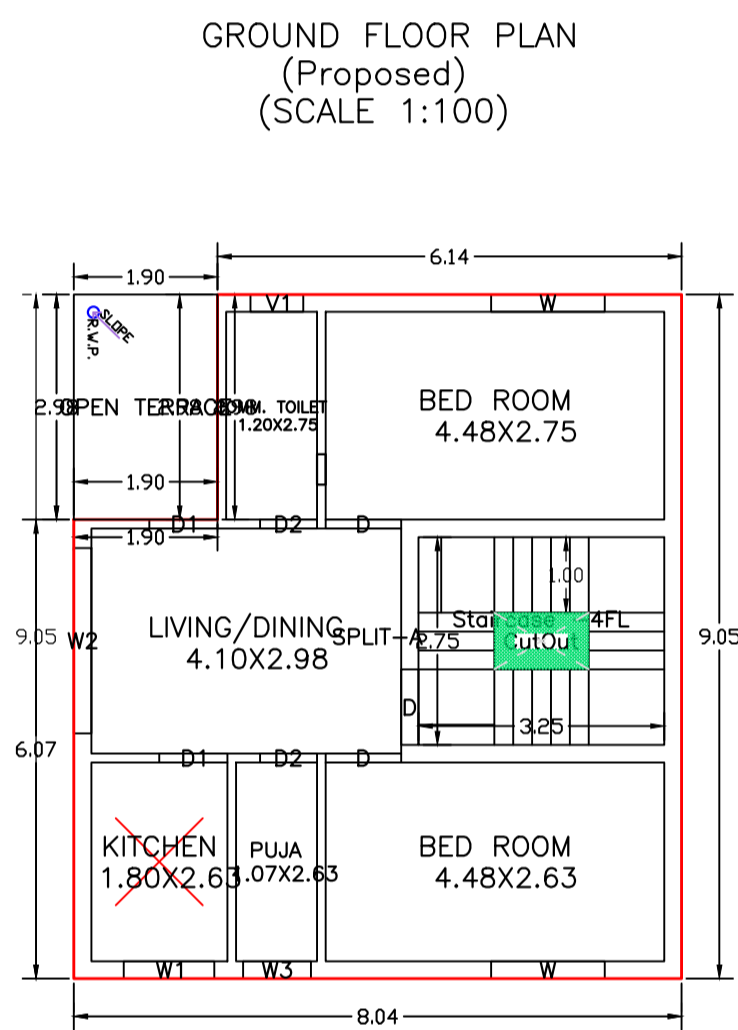

FIRST FLOOR PLAN (Proposed) (SCALE 1:100)

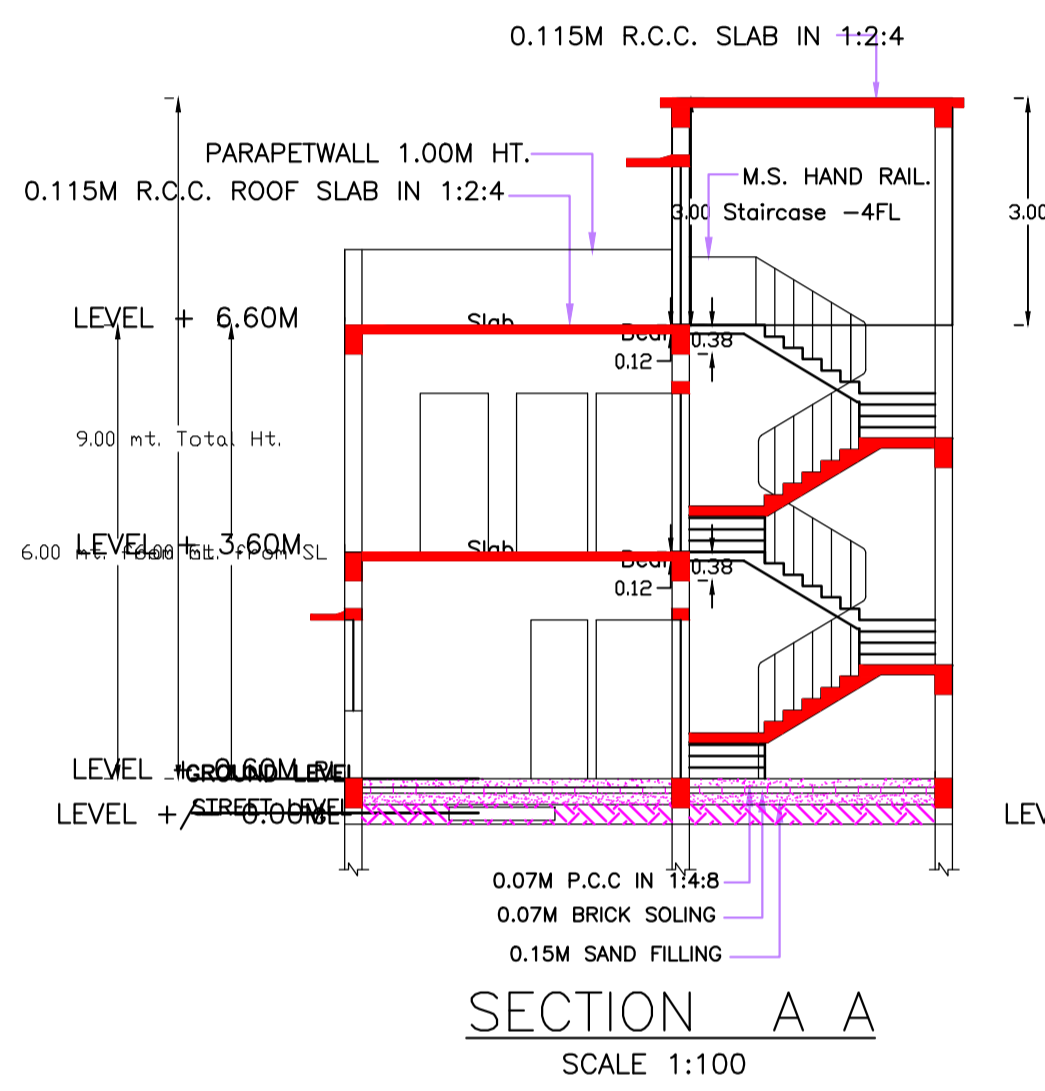

SECTION A A SCALE 1:100

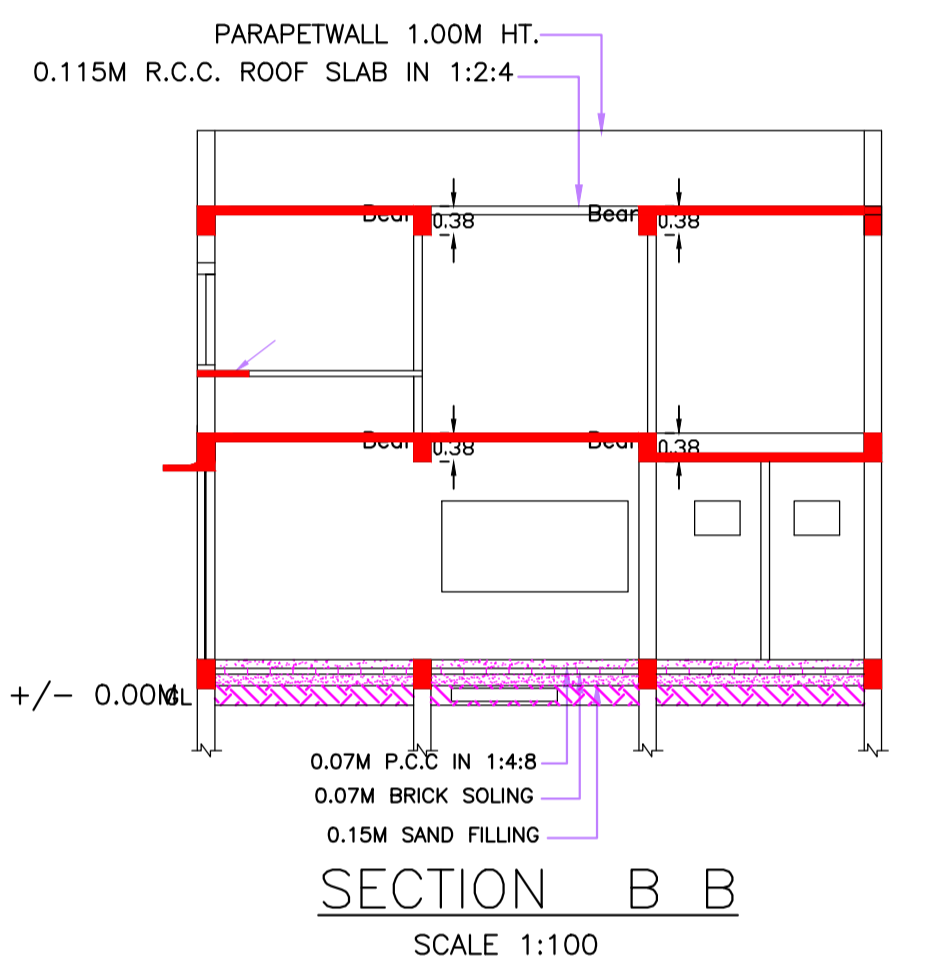

SECTION B B SCALE 1:100

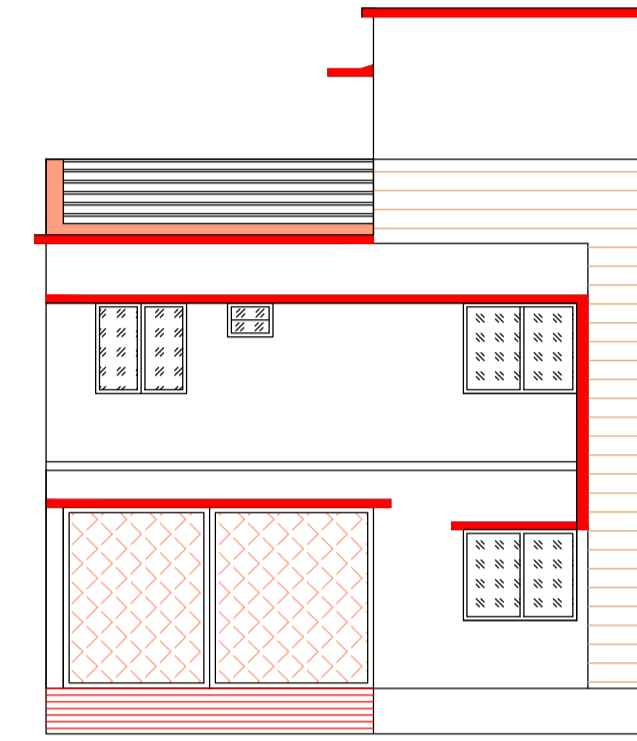

FRONT ELEVATION SCALE 1:100

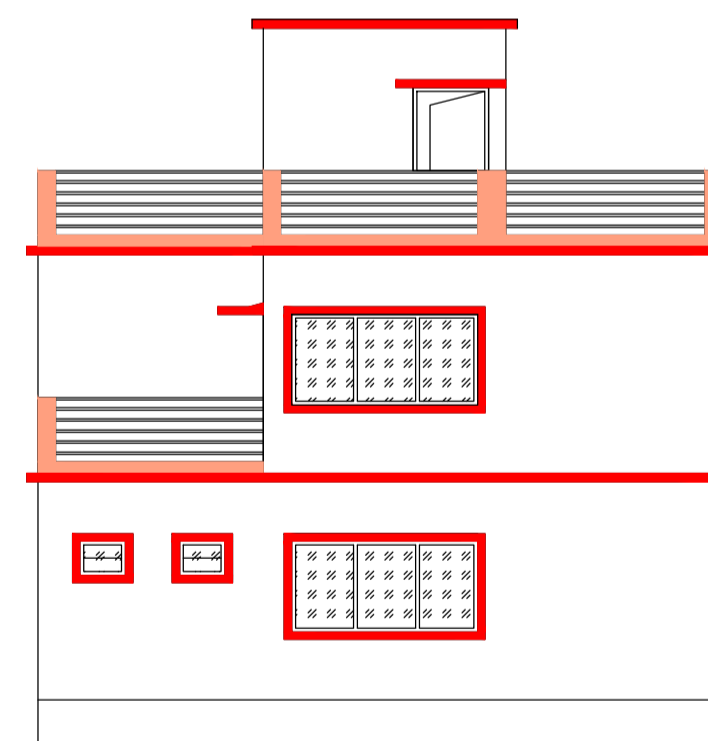

SOUTH SIDE ELEVATION SCALE 1:100

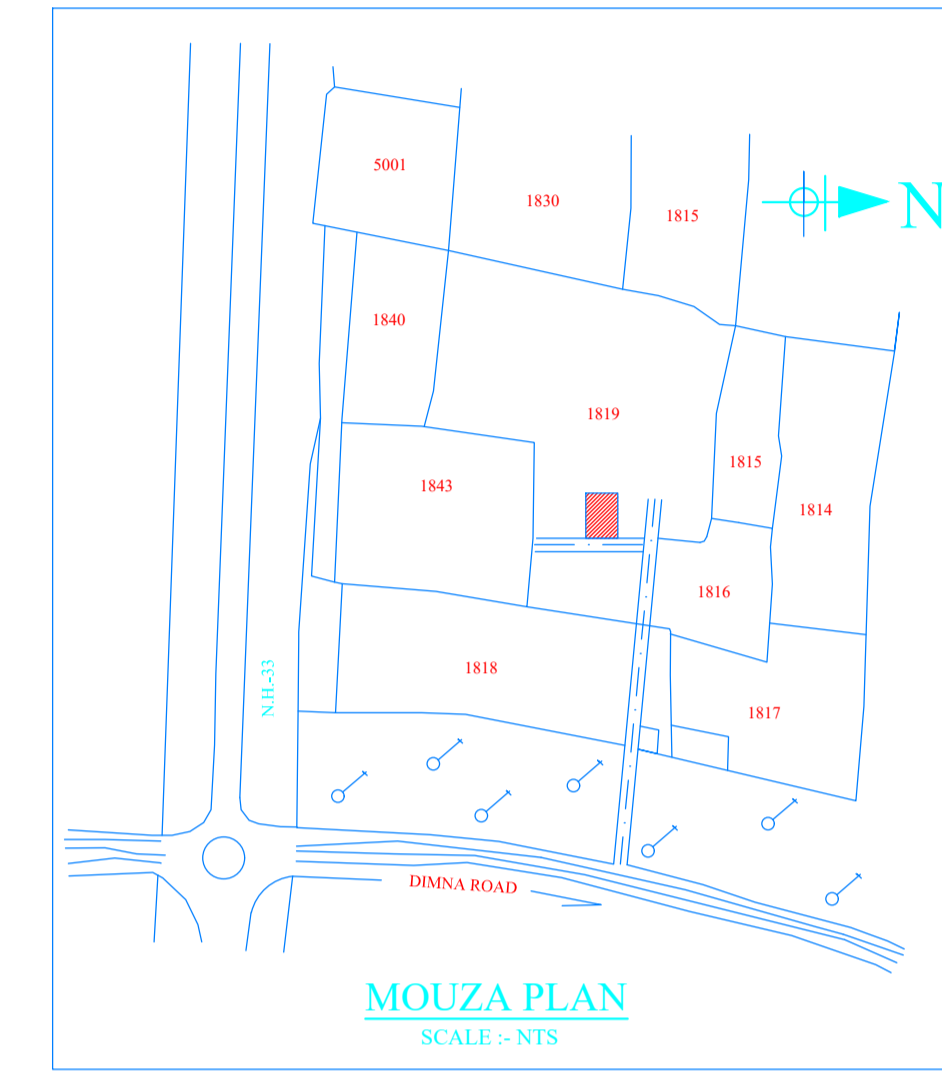

MOUZA PLAN SCALE :- NTS

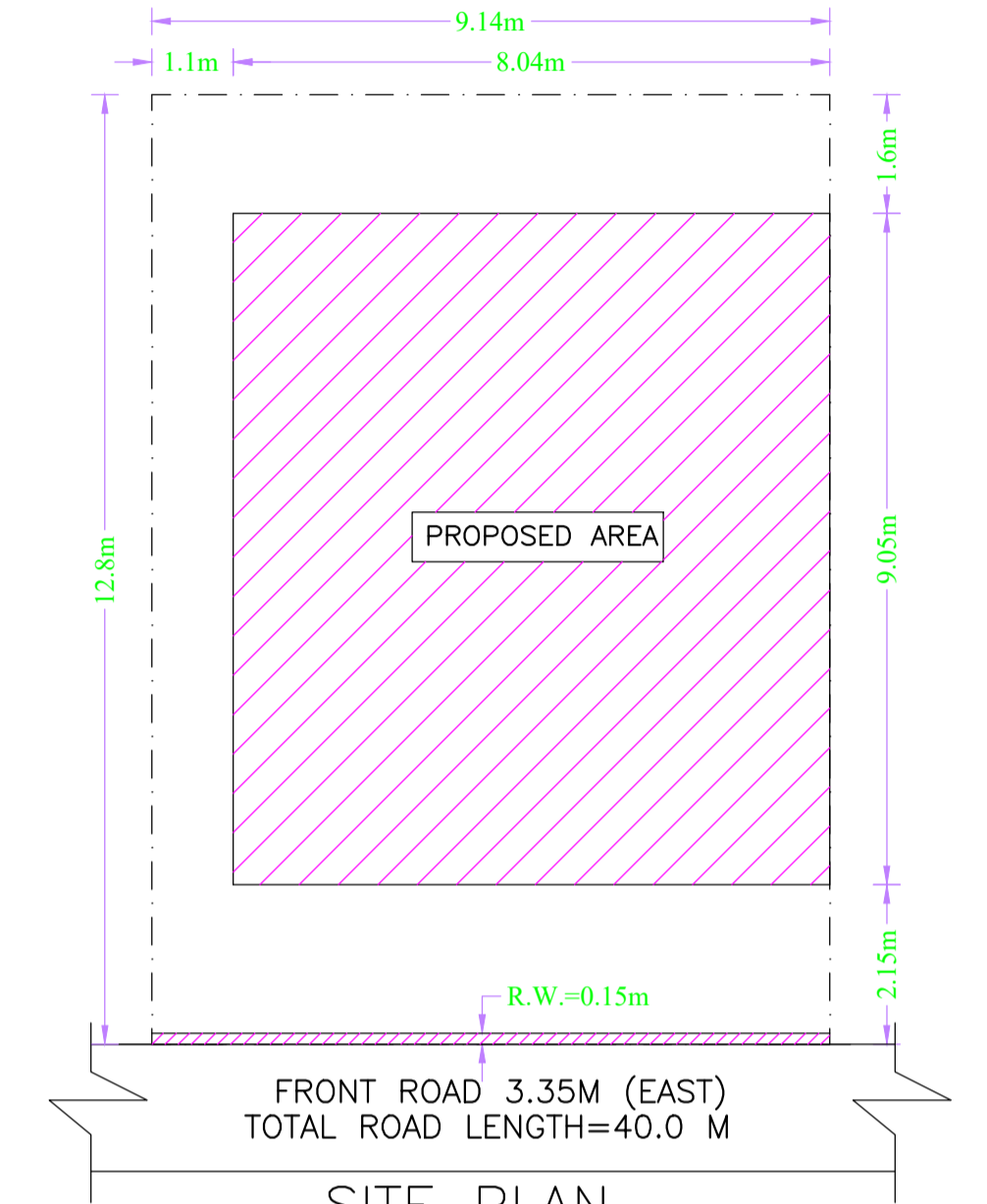

SITE PLAN SCALE 1:100

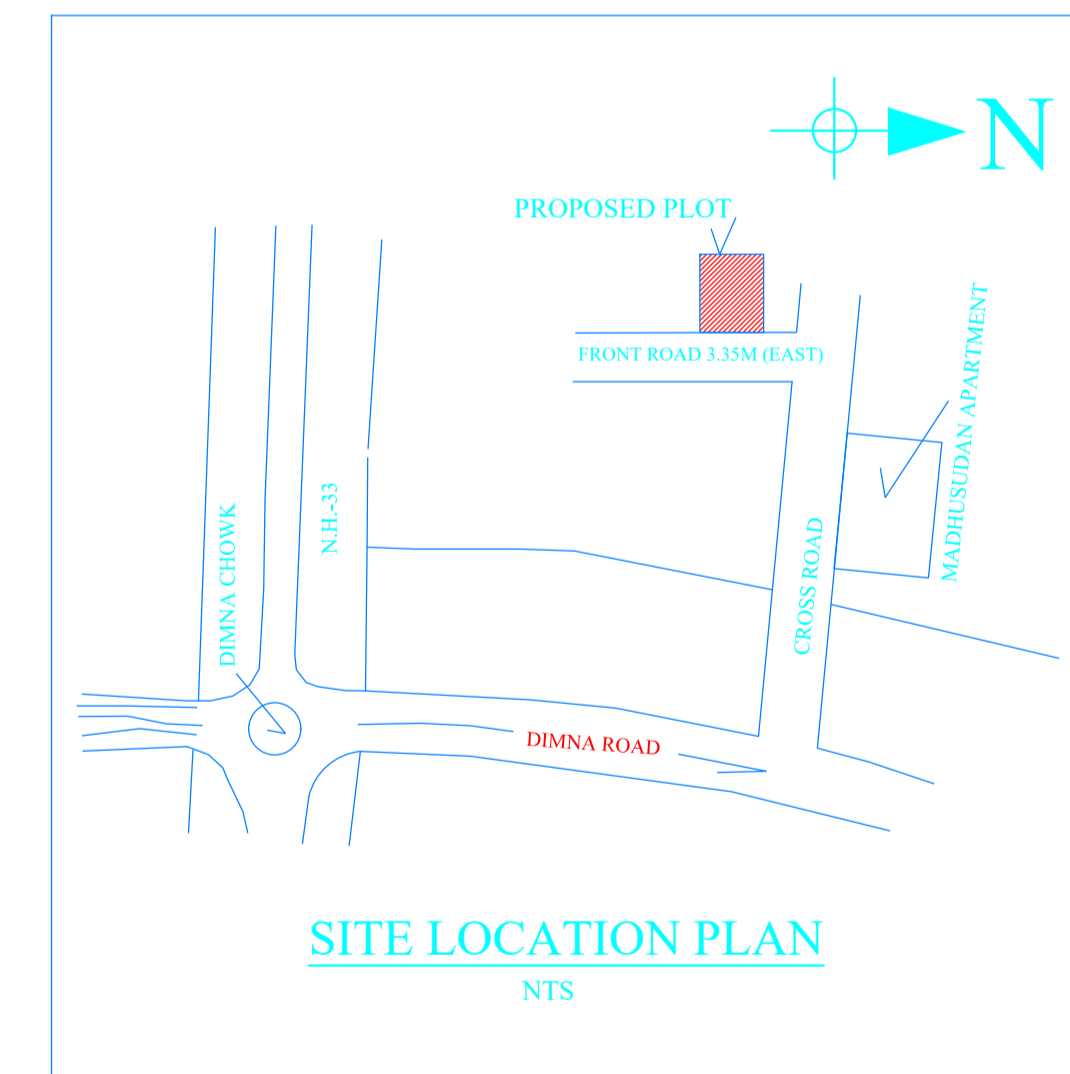

SITE LOCATION PLAN NTS

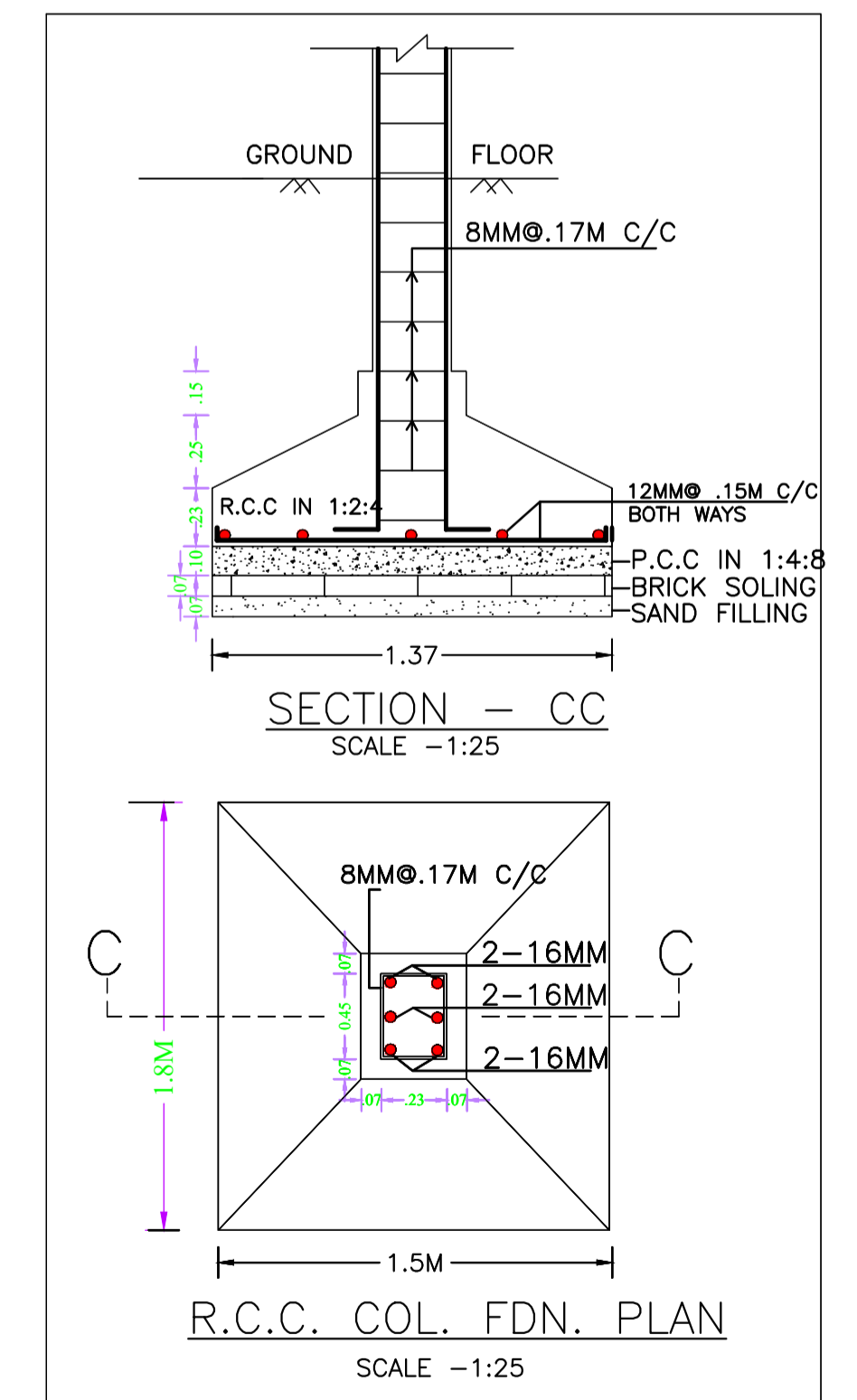

SECTION - CC SCALE -1:25

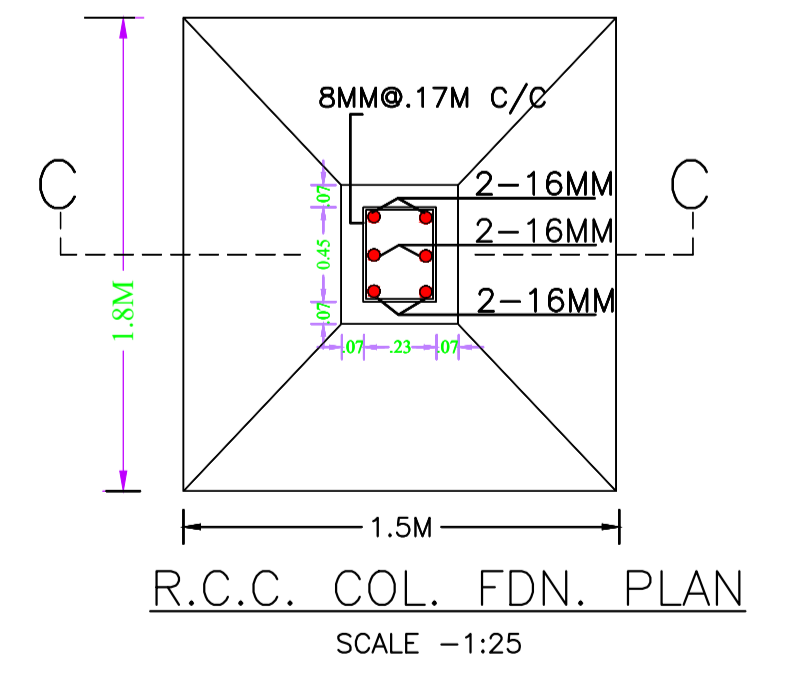

R.C.C. COL. FDN. PLAN SCALE -1:25

SCHEDULE OF DOOR:

BUILDING NAME	NAME	LENGTH	HEIGHT	NOS
A (MRS PUJA WO MR RAJIV DAS)	D2	0.75	2.10	04
A (MRS PUJA WO MR RAJIV DAS)	D1	0.90	2.10	02
A (MRS PUJA WO MR RAJIV DAS)	D	1.00	2.10	04

SCHEDULE OF WINDOW/VENTILATION:

BUILDING NAME	NAME	LENGTH	HEIGHT	NOS
A (MRS PUJA WO MR RAJIV DAS)	V1	0.70	0.70	03
A (MRS PUJA WO MR RAJIV DAS)	W3	0.90	1.20	01
A (MRS PUJA WO MR RAJIV DAS)	W1	1.20	1.20	01
A (MRS PUJA WO MR RAJIV DAS)	W	1.50	1.20	03
A (MRS PUJA WO MR RAJIV DAS)	W2	2.45	1.20	01

UnitBUA Table for Building :A (MRS PUJA WO MR RAJIV DAS)

FLOOR	Name	UnitBUA Type	UnitBUA Area	Carpet Area	No. of Rooms	No. of Tenement
FIRST FLOOR PLAN	SPLIT-A	FLAT	0.00	0.00	6	0
GROUND FLOOR PLAN	SPLIT-A	FLAT	88.65	88.58	3	1
Total:	-	-	88.65	88.58	9	1

Building :A (MRS PUJA WO MR RAJIV DAS)

Floor Name	Gross Builtup Area	Deductions From Gross BUA/Area in Sq.mt.		Proposed FAR Area (Sq.mt.)	Total FAR Area (Sq.mt.)	Total Consumed Additional FAR Area (Sq.mt.)	Trmt (No.)
		Cutout	Parking				
Ground Floor	72.77	0.94	71.83	35.93	35.93	35.93	01
First Floor	67.10	0.94	66.16	0.00	66.16	66.16	00
Terrace Floor	0.00	0.00	0.00	0.00	0.00	0.00	00
Total:	139.87	1.88	137.99	35.90	102.09	102.09	01
Total Number of Same Buildings	1						
Total:	139.87	1.88	137.99	35.90	102.09	102.09	01

LTP NAME AND SIGNATURE	STRUCTURAL ENG'S NAME AND SIGNATURE	BUILDER NAME AND SIGNATURE	DIGITAL SIGNATURE
Chandrika Sharma MNAC/DFTMN/0017/2017			

Proposal Basic Information

Proposal File No.	MNAC/BP/0084/W09/2024
Owner Name	MRS PUJA W.O MR RAJIV DAS
Khata No	422
Plot No	1819
Village Name	Dimna
Use	Residential
SubUse	Bungalow/ Dwelling / Non Apartment

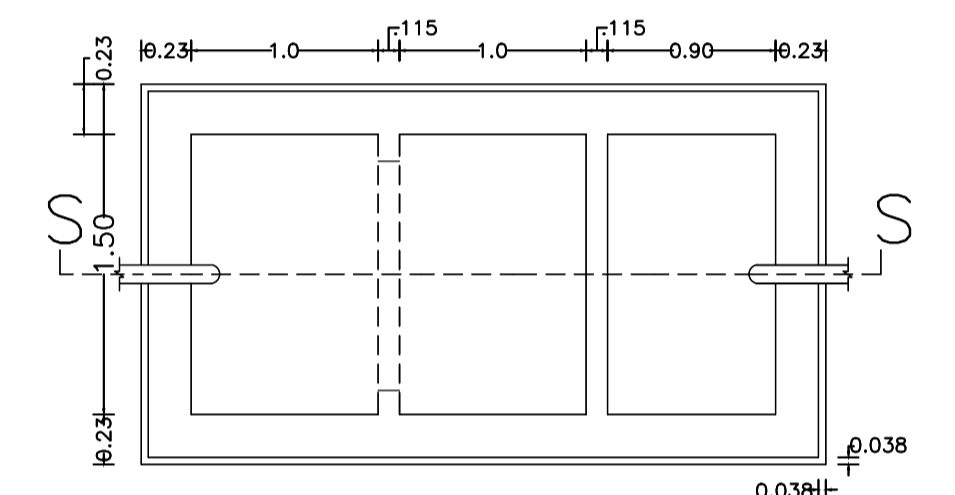
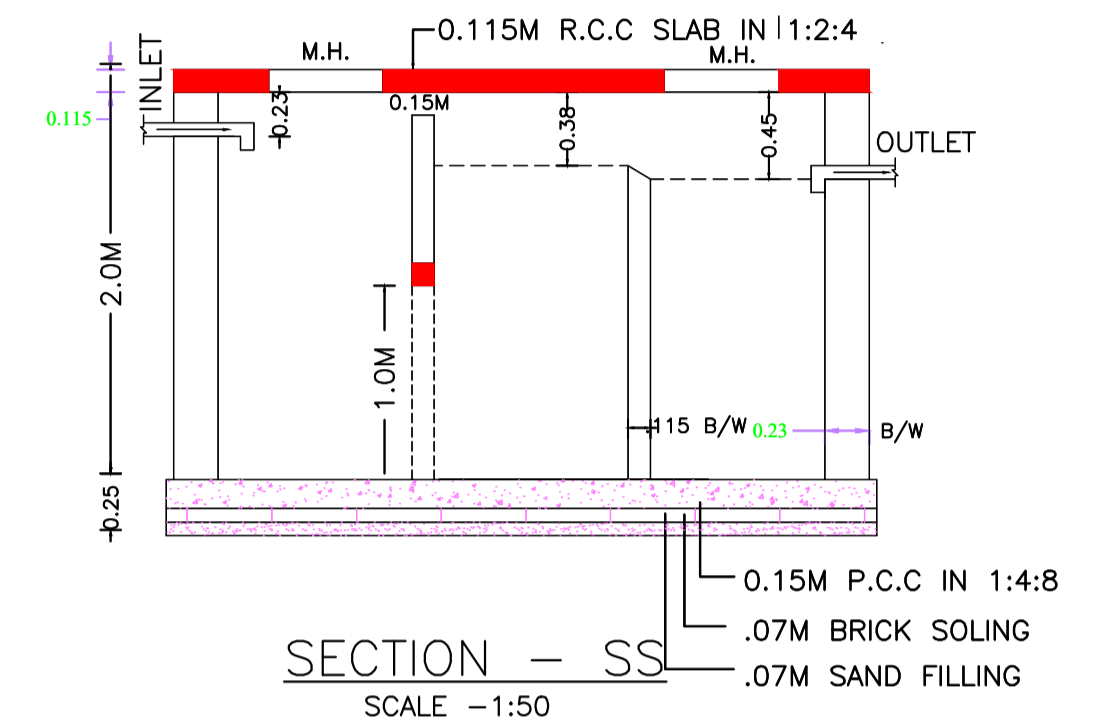

SEPTIC TANK PLAN
NTS

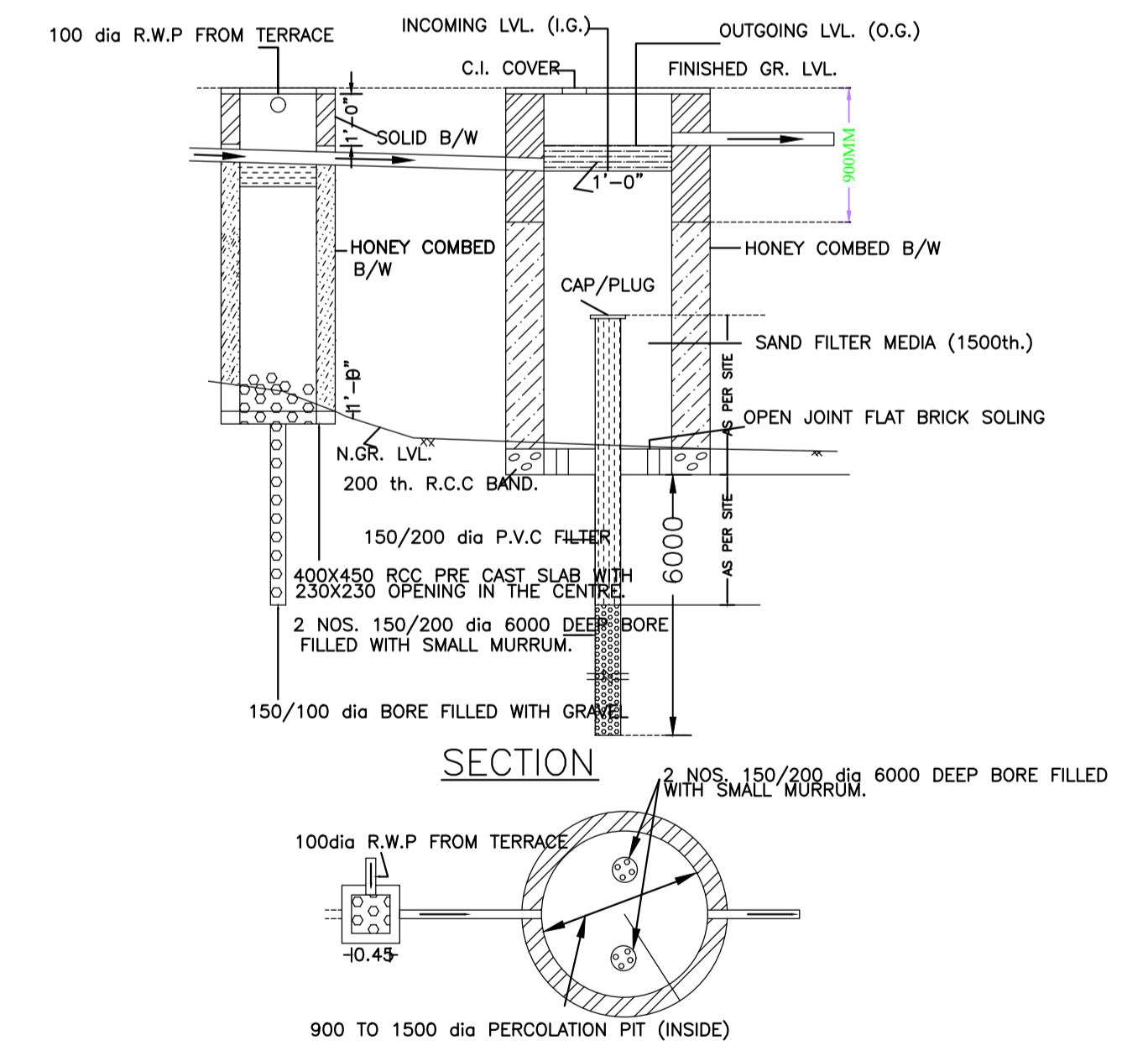

WATER HARVESTING PLAN (NTS)
NTS

LTP NAME AND SIGNATURE	STRUCTURAL ENG'S NAME AND SIGNATURE	BUILDER NAME AND SIGNATURE	DIGITAL SIGNATURE
Chandrika Sharma MNAC/DFTMN/0017/2017			