

FAR & Tenement Details (Table 4c-1)

Building	No. of Same Bldg	Total Built Up Area (Sq.mt.)	Deductions (Area in Sq.mt.)		Proposed FAR Area (Sq.mt.)	Total FAR Area (Sq.mt.)	Total Consumed Additional FAR Area (Sq.mt.)	Trnmt (No.)
			Parking	Resi.				
A (RESIDENTIAL BUILDING)	1	349.41	37.93	311.48	311.48	311.48	02	
Grand Total :	1	349.41	37.93	311.48	311.48	311.48	02	

Proposal Basic Information

Proposal File No.	MNAC/BP/0011/W09/2024
Owner Name	MISS SANDHYA RANI TIGGA
Khata No	281
Plot No	2122, 2141
Village Name	Mango
Use	Residential
SubUse	Bungalow/ Dwelling / Non Apartment

Required Parking (Table 7a)

Building Name	Type	SubUse	Area (Sq.mt.)	Units		Car		Visitors Car		TwoWheeler		
				Reqd.	Prop.	Reqd./Unit	Reqd.	Prop.	Reqd./Unit	Reqd.	Prop.	
A (RESIDENTIAL BUILDING)	Residential	Bungalow/ Dwelling / Non Apartment	> 0	1	2.00	1.00	2	-	-	-	-	
				1	2.00	-	-	1	1	-	-	-
Total :							2	2	1	1	0	4

Parking Check (Table 7b)

Vehicle Type	Reqd.		Prop.	
	No.	Area	No.	Area
Car	-	-	2	25.00
Total Car	2	25.00	2	25.00
Visitor's Car Parking	-	-	1	12.50
Total Visitor Parking	1	12.50	1	12.50
TwoWheeler	-	-	4	8.00
Total TwoWheeler	-	-	4	8.00
Other Parking	-	-	-	-
Total		37.50		66.43

AREA STATEMENT MANGO MUNICIPAL CORPORATION	VERSION NO: 1.0.69
	VERSION DATE: 16/10/2020
PROJECT DETAIL:	
Region: JHARKHAND URBAN LOCAL BODIES	Plot Use: Residential
District: EAST SINGBHUM	Plot SubUse: Bungalow/ Dwelling / Non Apartment
Authority: MANGO MUNICIPAL CORPORATION	PlotNearby/ReligiousStructure: NA
Inward No: MNAC/BP/0011/W09/2024	PlotSubPlot No: 2122, 2141
Application Type: General Proposal	North: Plot No. - RESIDENTIAL PLOT XV
Project Type: Building Permission	South: Plot No. - RESIDENTIAL PLOT XVII
Nature of Development: New	East: Road Width - 5.49
Location of Development Area: Old Area	West: Plot No. - BOUNDARY WALL
AREA DETAILS:	SQ.MT.
AREA OF PLOT (Minimum)	(A) 185.41
NET AREA OF PLOT(Gross Plot Area - Deduction from Gross Plot area)	(A-Deductions) 185.41
Deduction for Balance Plot Area(from Gross Plot Area)	
Common Plot	16.80
Total	16.80
BALANCE AREA OF PLOT(Net Plot Area - Recreational/Amenity space)	(A-Deductions) 168.61
PLOT AREA FOR COVERAGE(Net Plot Area)	(A-Deductions) 185.41
Plot Area for FAR (Net Plot Area + Road Widening Area)	(A-Deductions) 185.41
COVERAGE CHECK	
Permissible Coverage area (70.00 %)	129.79
Proposed Coverage Area (62.82 %)	116.47
Total Prop. Coverage Area (62.82 %)	116.47
Balance coverage area (7.18 %)	13.32
FAR CHECK	
Perm. FAR Area (1.800)	333.74
Total Perm. FAR area	333.74
Residential FAR	311.47
Proposed FAR Area	311.47
Total Proposed FAR Area	311.47
Consumed FAR (Factor)	1.68
Balance FAR Area	22.27
BUILT UP AREA CHECK	
Total Proposed BuiltUp Area	349.41
ARCHITECT (Regd)	L K Suman
ENGINEER (Regd)	
SUPERVISOR (Regd)	
OWNER (Regd)	MISS SANDHYA RANI TIGGA
DEVELOPMENT AUTHORITY	LOCAL BODY

COLOR INDEX	
PLOT BOUNDARY	
ABUTTING ROAD	
PROPOSED CONSTRUCTION	
COMMON PLOT	
ROAD WIDENING AREA	
EXISTING (To be retained)	
EXISTING (To be demolished)	

Buildingwise Floor FAR Details

Floor Name	Building Name		Total	
	Proposed Built Up Area (Sq.mt.)	Proposed FAR Area (Sq.mt.)	Total Proposed Built Up Area (Sq.mt.)	Total FAR Area (Sq.mt.)
Ground Floor	116.47	78.54	116.47	78.54
First Floor	116.47	116.47	116.47	116.47
Second Floor	116.47	116.47	116.47	116.47
Terrace Floor	0.00	0.00	0.00	0.00
Total :	349.41	311.48	349.41	311.48

Building USE/SUBUSE Details

Building Name	Building Use	Building SubUse	Building Structure
A (RESIDENTIAL BUILDING)	Residential	Bungalow/ Dwelling / Non Apartment	Non-Highrise

LTP NAME AND SIGNATURE	STRUCTURAL ENG'S NAME AND SIGNATURE	BUILDER NAME AND SIGNATURE	DIGITAL SIGNATURE
L K Suman MNAC/ENG/0008/2016			

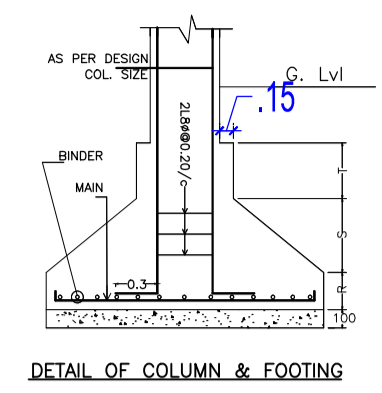
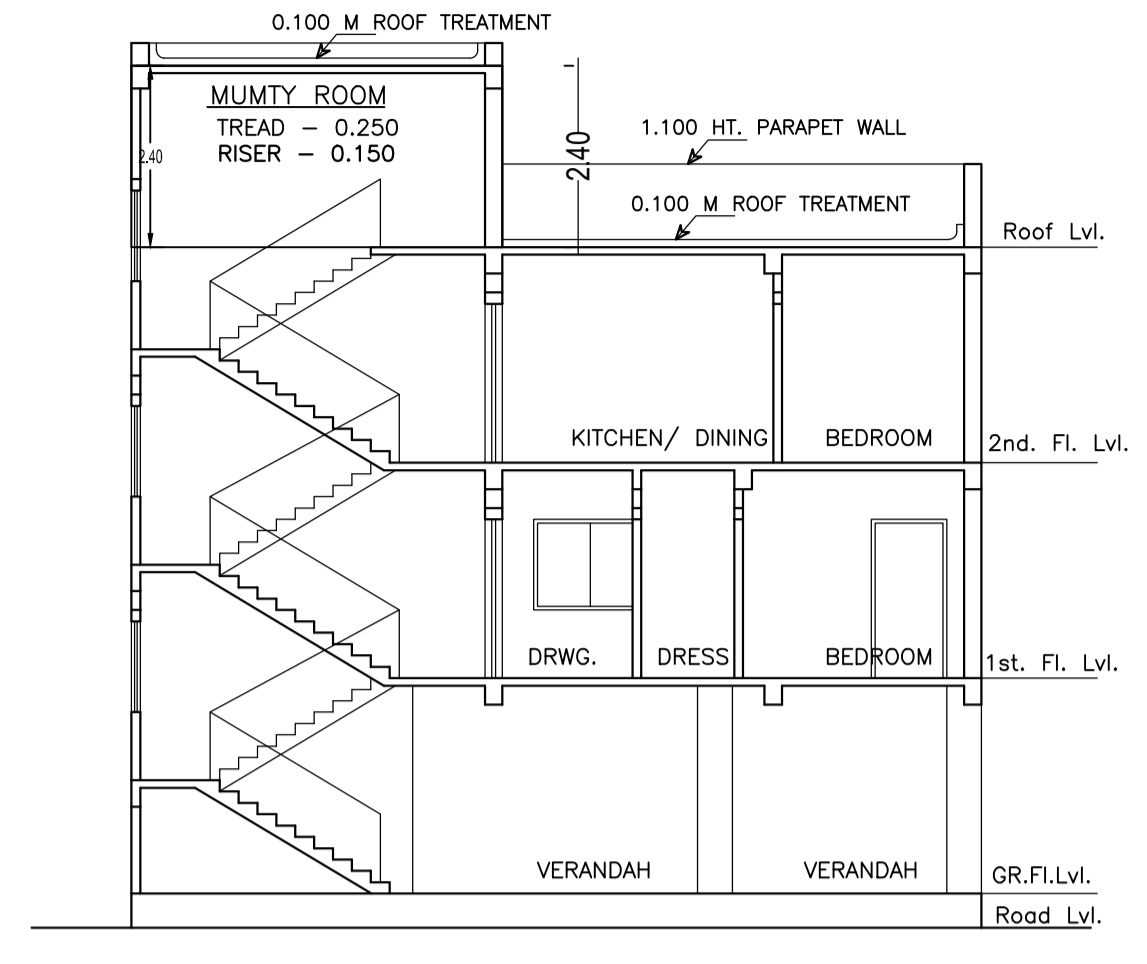
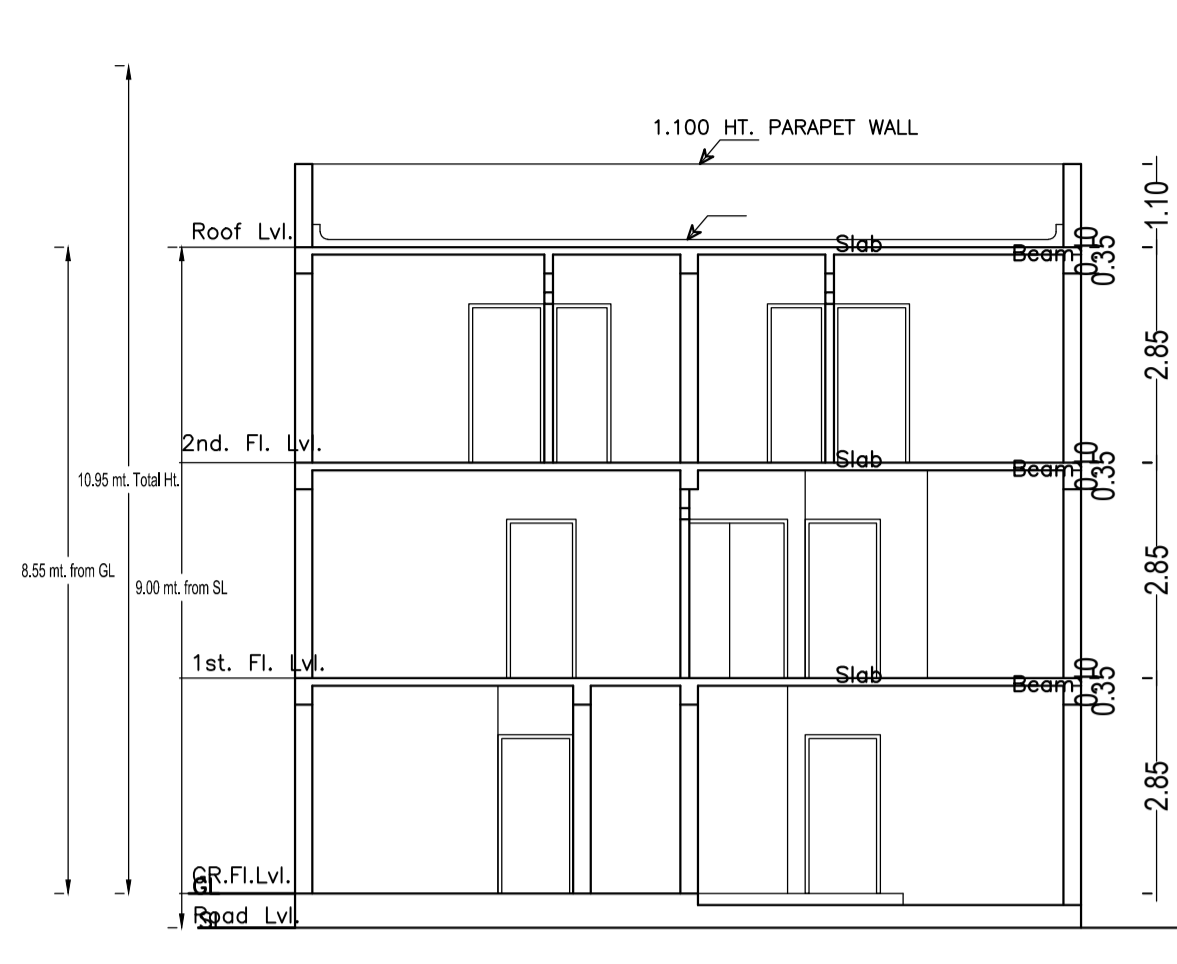
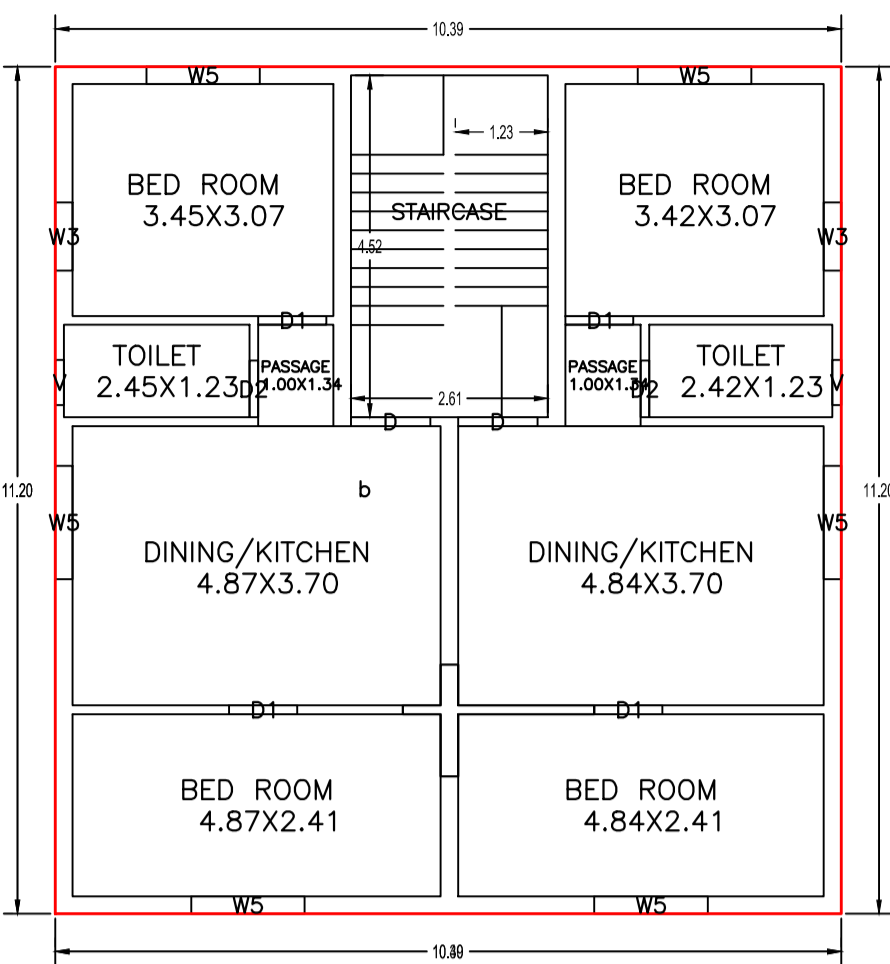
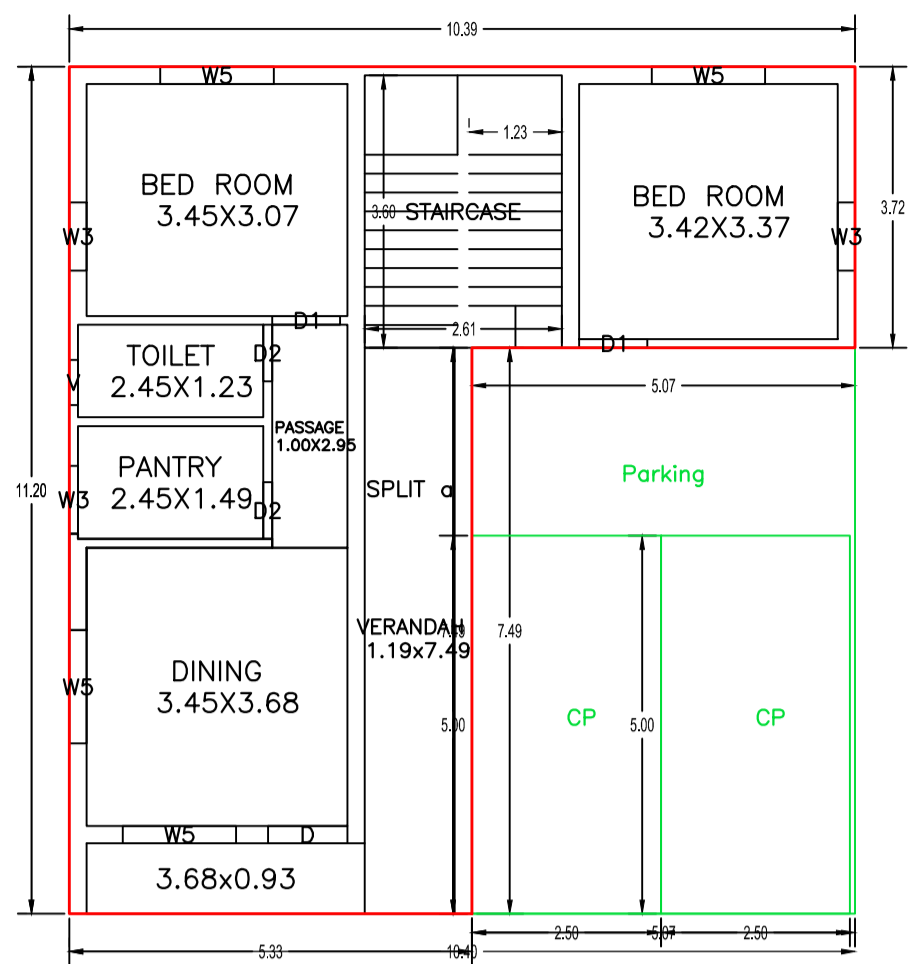

Proposal Basic Information

Proposal File No.	MNAC/BP/0011/W09/2024
Owner Name	MISS SANDHYA RANI TIGGA
Khata No	281
Plot No	2122, 2141
Village Name	Mango
Use	Residential
SubUse	Bungalow/ Dwelling / Non Apartment

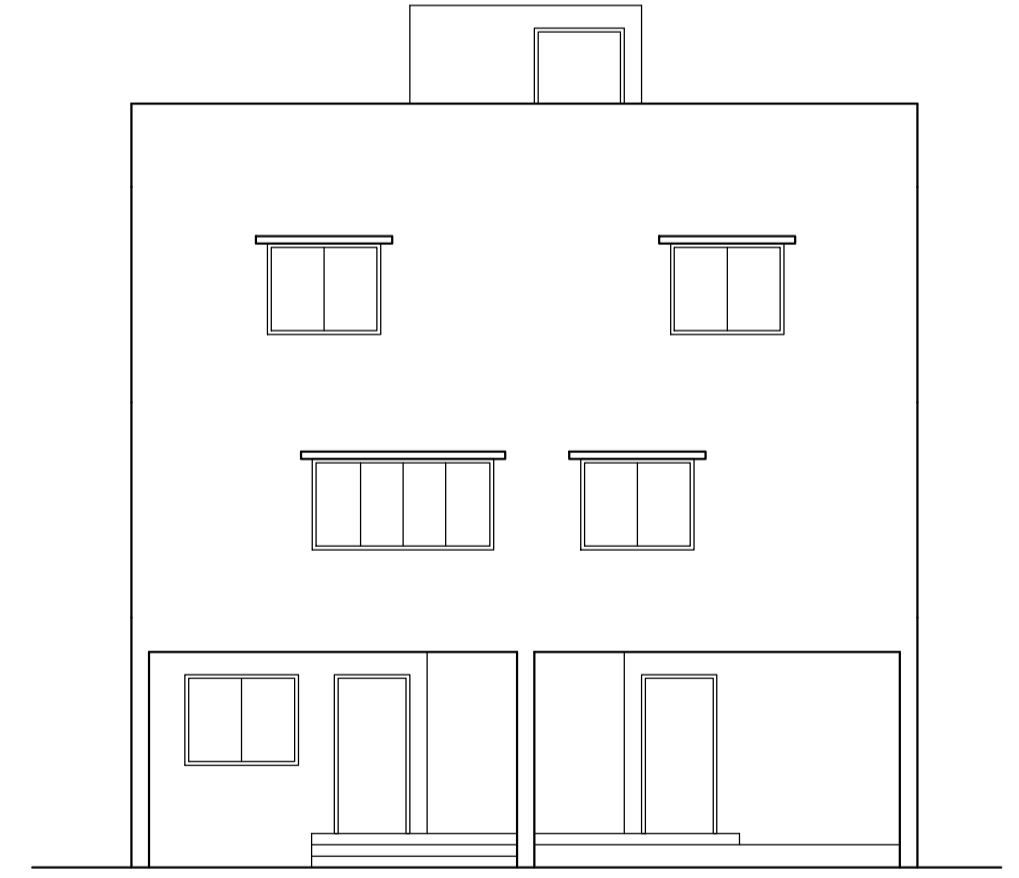
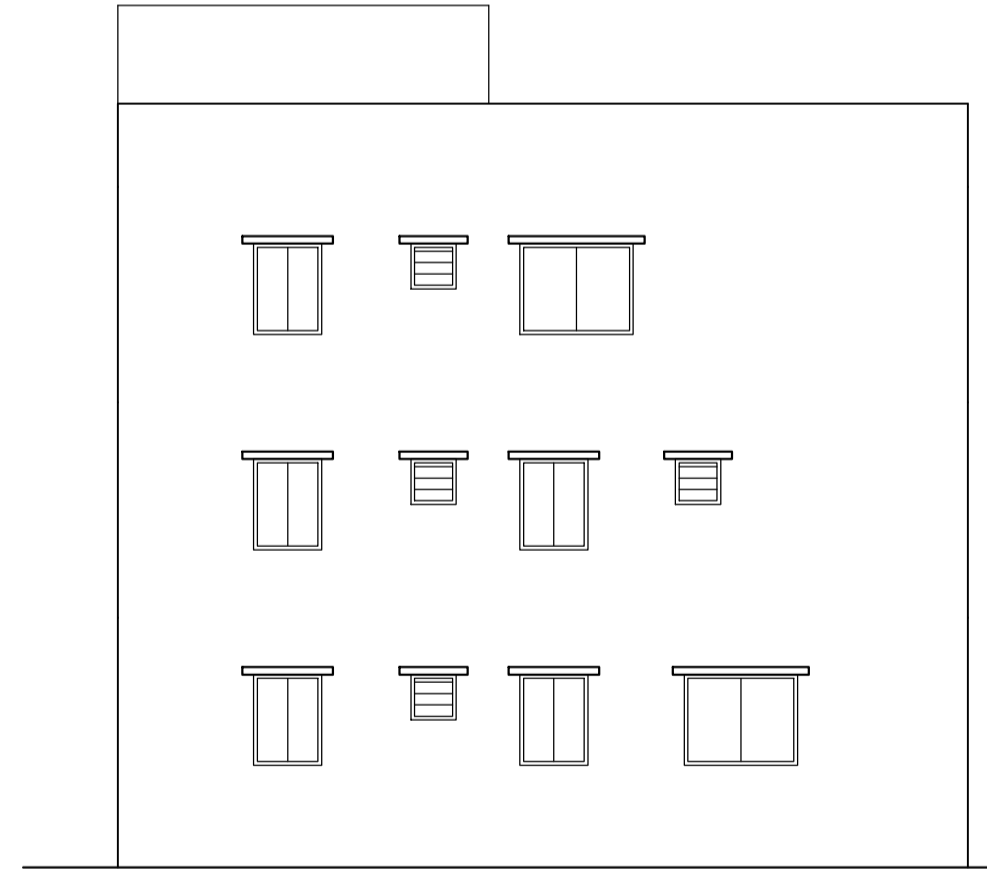
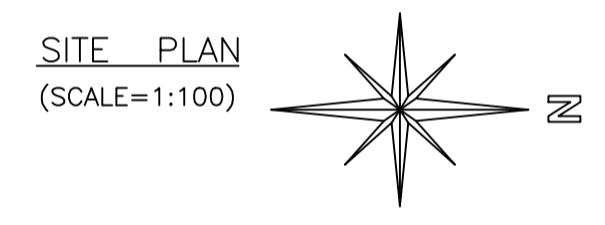
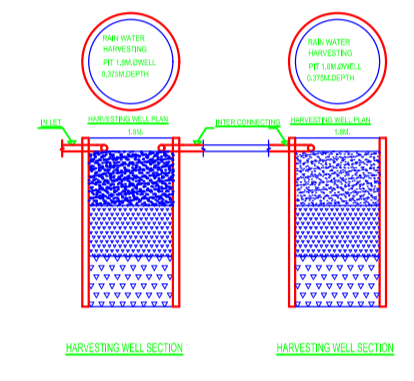
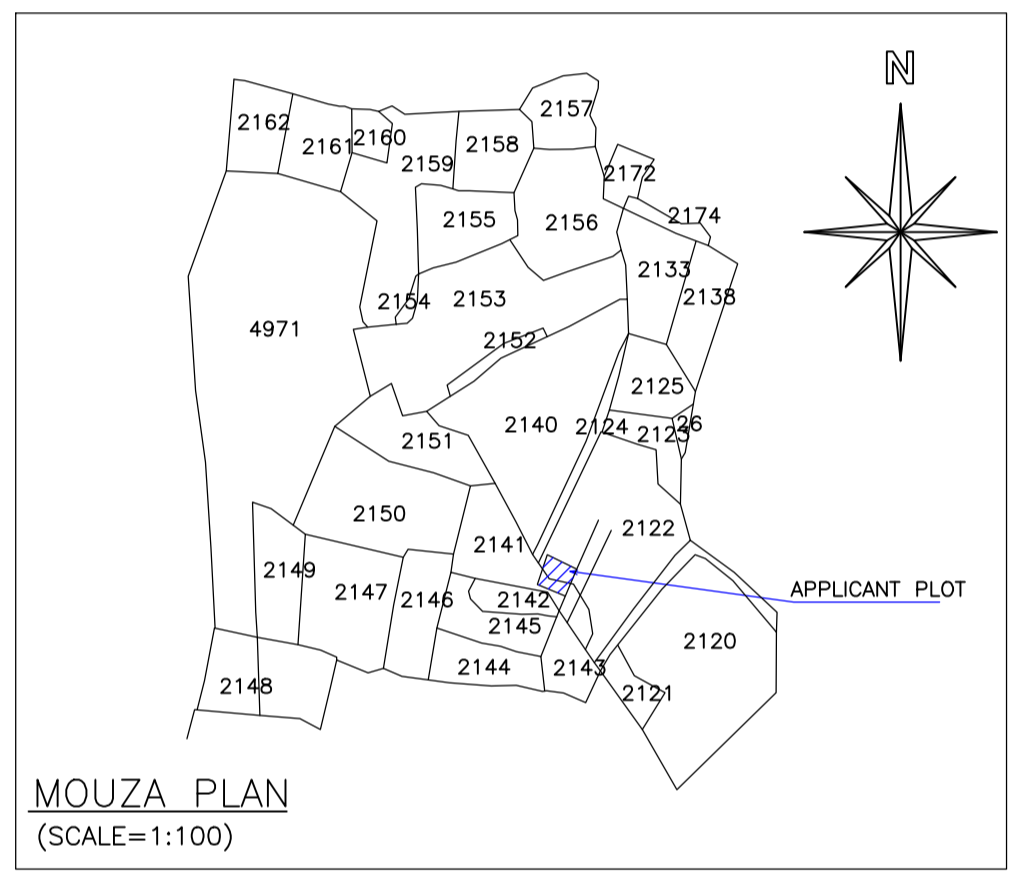
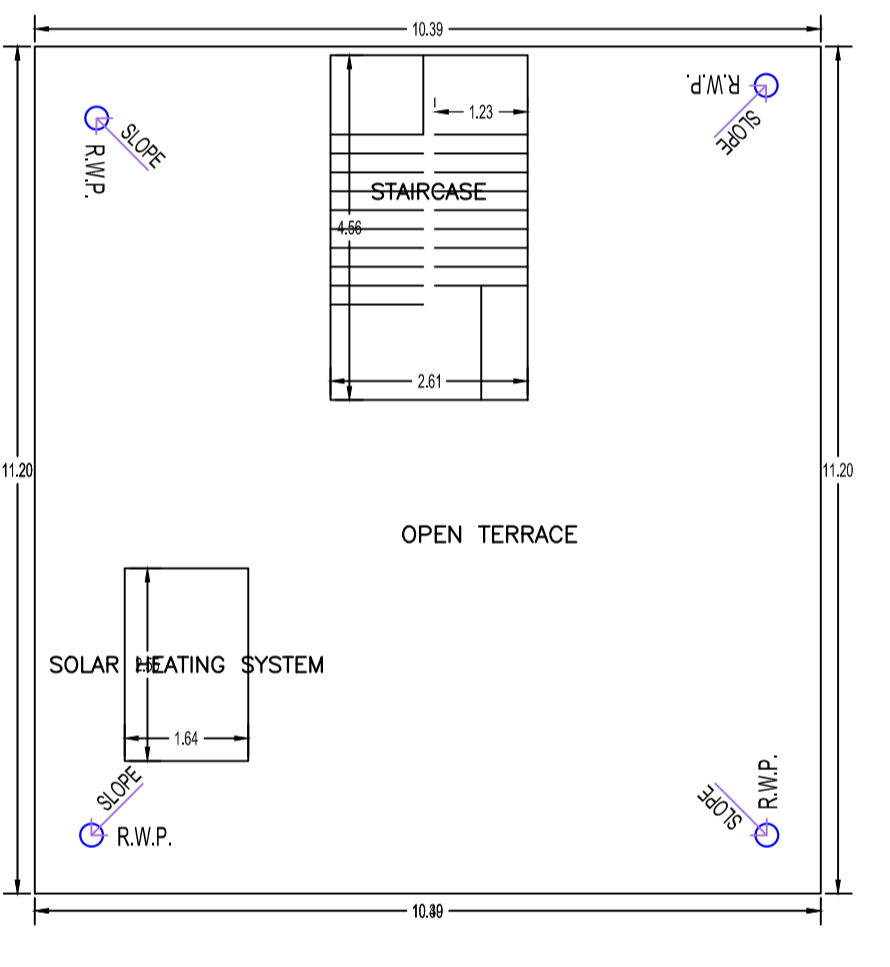
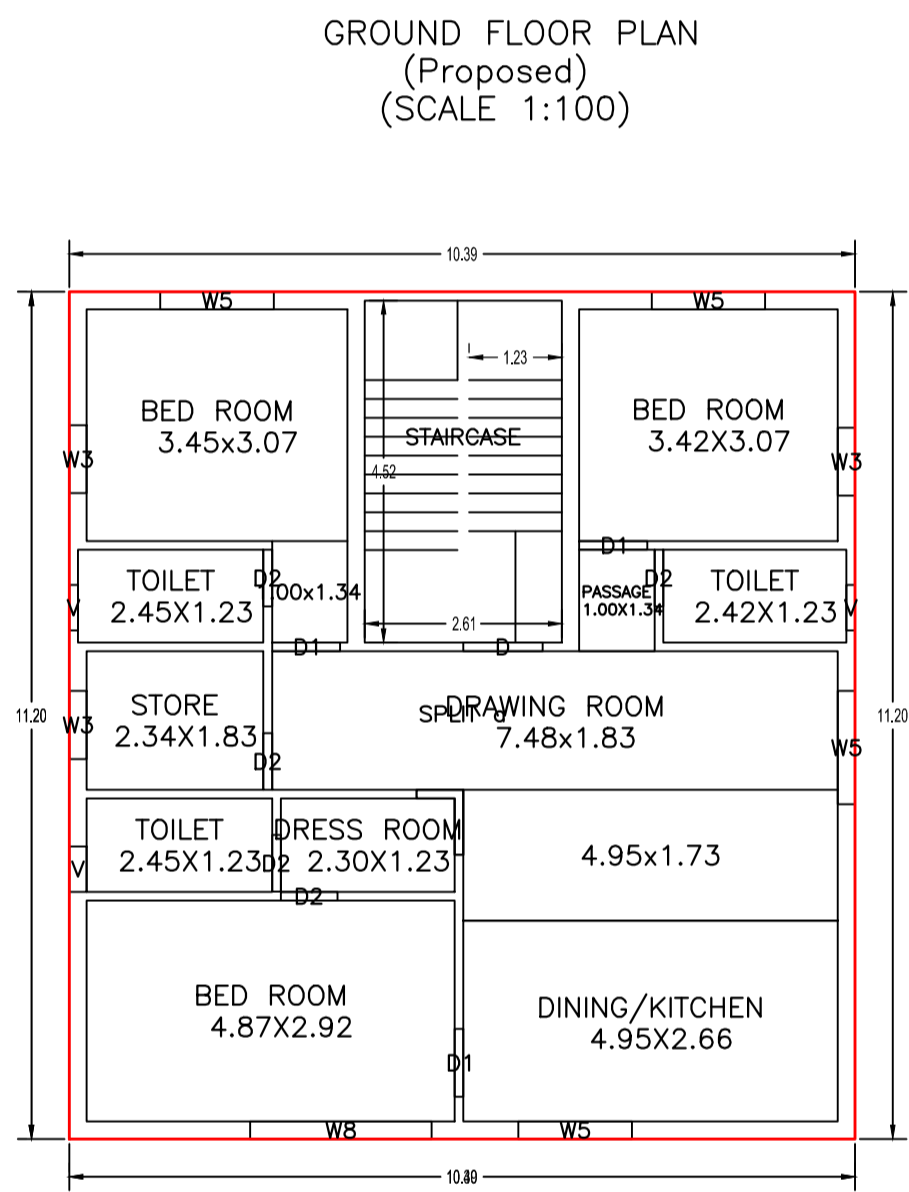
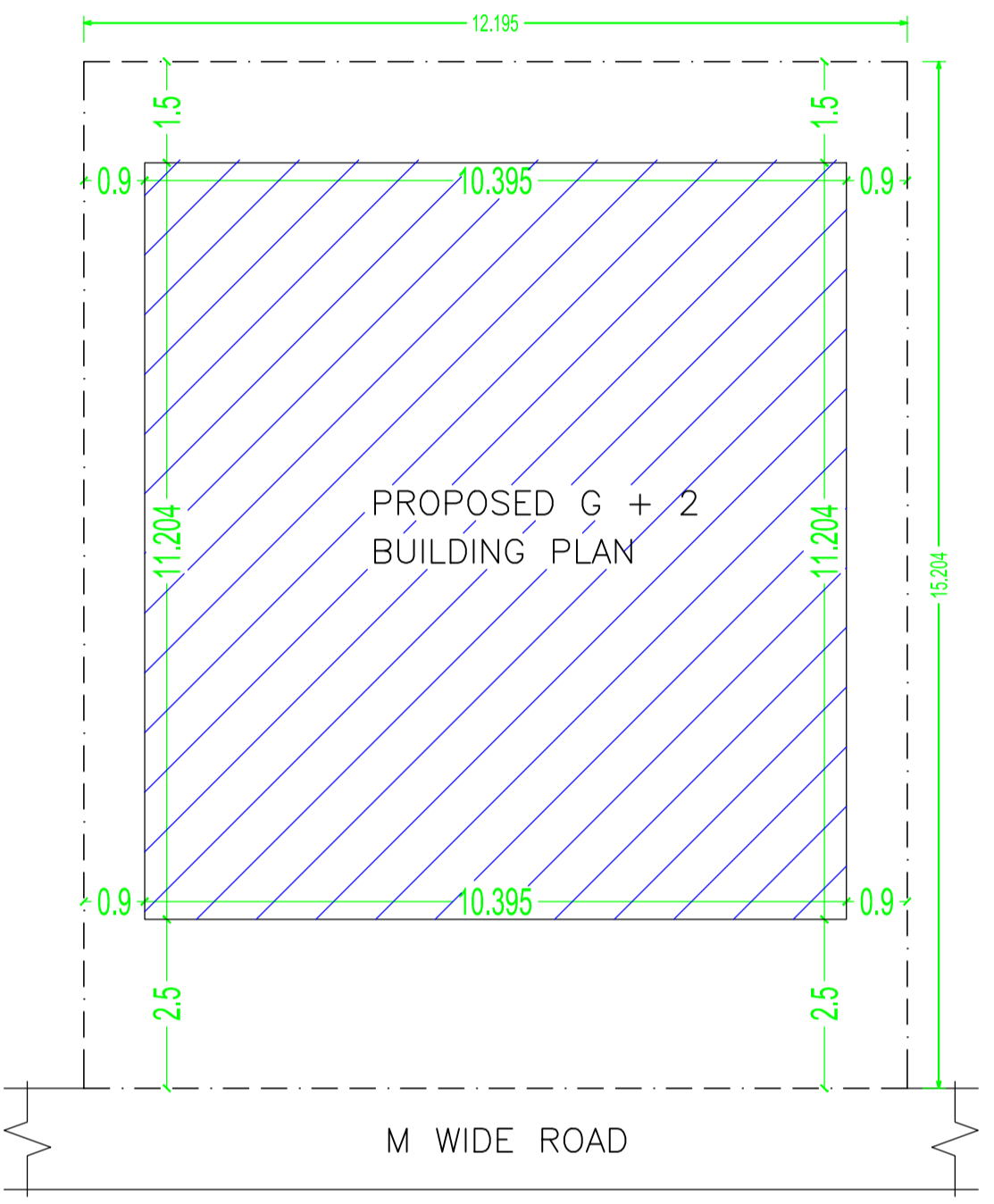

Building :A (RESIDENTIAL BUILDING)

Floor Name	Total Built Up Area (Sq.mt.)	Deductions (Area in Sq.mt.)	Proposed FAR Area (Sq.mt.)	Total FAR Area (Sq.mt.)	Total Consumed Additional FAR Area (Sq.mt.)	Trmt (No.)
Ground Floor	116.47	37.93	78.54	78.54	78.54	01
First Floor	116.47	0.00	116.47	116.47	116.47	00
Second Floor	116.47	0.00	116.47	116.47	116.47	01
Terrace Floor	0.00	0.00	0.00	0.00	0.00	00
Total :	349.41	37.93	311.48	311.48	311.48	02
Total Number of Same Buildings	1					
Total :	349.41	37.93	311.48	311.48	311.48	02

SCHEDULE OF DOOR:

BUILDING NAME	NAME	LENGTH	HEIGHT	NOS
A (RESIDENTIAL BUILDING)	D2	0.75	2.10	09
A (RESIDENTIAL BUILDING)	D1	0.90	2.10	09
A (RESIDENTIAL BUILDING)	D	1.05	2.10	04

SCHEDULE OF WINDOW/VENTILATION:

BUILDING NAME	NAME	LENGTH	HEIGHT	NOS
A (RESIDENTIAL BUILDING)	V	0.60	0.60	06
A (RESIDENTIAL BUILDING)	W3	0.90	1.20	08
A (RESIDENTIAL BUILDING)	W5	1.50	1.20	14
A (RESIDENTIAL BUILDING)	W8	2.40	1.20	01

UnitBUA Table for Building :A (RESIDENTIAL BUILDING)

FLOOR	Name	UnitBUA Type	UnitBUA Area	Carpet Area	No. of Rooms	No. of Tenement
GROUND FLOOR PLAN	SPLIT a	FLAT	195.01	194.28	7	1
FIRST FLOOR PLAN	SPLIT a	FLAT	0.00	0.00	11	0
SECOND FLOOR PLAN	b	FLAT	116.47	115.86	10	1
Total:	-	-	311.48	310.14	28	2

LTP NAME AND SIGNATURE	STRUCTURAL ENG'S NAME AND SIGNATURE	BUILDER NAME AND SIGNATURE	DIGITAL SIGNATURE
L K Suman MNAC/ENG/0008/2016			