

Proposal Basic Information	
Proposal File No.	MNAC/BP/001/W09/2024
Owner Name	SMT. BINA GOSWAMI WO MR. RAJENDRA GOSWAMI
Khata No	278
Plot No	3389
Village Name	Mango
Use	Residential
SubUse	Bungalow/ Dwelling / Non Apartment

AREA STATEMENT MANGO MUNICIPAL CORPORATION		VERSION NO.: 1.0.68
PROJECT DETAIL:		VERSION DATE: 16/10/2020
Region: JHARKHAND URBAN LOCAL BODIES	Plot Use: Residential	
District: EAST SINGHBHUM	Plot SubUse: Bungalow/ Dwelling / Non Apartment	
Authority: MANGO MUNICIPAL CORPORATION	PlotNearbyReligiousStructure: NA	
Inward No: MNAC/BP/001/W09/2024	Plot/SubPlot No: 3389	
Application Type: General Proposal	North: Road Width - 3.67	
Project Type: Building Permission	South: Plot No. - 3389	
Nature of Development: New	East: Plot No. - 3389	
Location of Development Area: Old Area	West: Plot No. - 3389	
AREA DETAILS:		SQ.MT.
AREA OF PLOT (Minimum)	(A)	126.44
NET AREA OF PLOT (Gross Plot Area - Deduction from Gross Plot area)	(A-Deductions)	126.44
Deduction for Balance Plot Area (from Gross Plot Area)		
Common Plot		12.28
Total		12.28
BALANCE AREA OF PLOT (Net Plot Area - Recreational/Amenity space)	(A-Deductions)	114.16
PLOT AREA FOR COVERAGE (Net Plot Area)	(A-Deductions)	126.44
Plot Area for FAR (Net Plot Area + Road Widening Area)	(A-Deductions)	126.44
COVERAGE CHECK		
Permissible Coverage area (70.00 %)		88.51
Proposed Coverage Area (64.35 %)		81.37
Total Prop. Coverage Area (64.35 %)		81.37
Balance coverage area (5.65 %)		7.14
FAR CHECK		
Perm. FAR Area (1.500)		189.66
Total Perm. FAR area		189.66
Residential FAR		103.36
Proposed FAR Area		103.36
Total Proposed FAR Area		103.36
Consumed FAR (Factor)		0.82
Balance FAR Area		86.30
BUILT UP AREA CHECK		
Total Proposed BuiltUp Area		162.74
ARCHITECT (Regd)	Chandrika Sharma	
ENGINEER (Regd)		
SUPERVISOR (Regd)		
OWNER (Regd)	SMT. BINA GOSWAMI WO MR. RAJENDRA GOSWAMI	
DEVELOPMENT AUTHORITY		LOCAL BODY

SITE PLAN

Building :A (RESIDENTIAL)

Floor Name	Total Built Up Area (Sq.mt.)	Deductions (Area in Sq.mt.)		Proposed FAR Area (Sq.mt.)	Total FAR Area (Sq.mt.)	Total Consumed Additional FAR Area (Sq.mt.)	Trmt (No.)
		Void	Parking				
Ground Floor	81.37	2.35	54.68	24.34	24.34	24.34	01
First Floor	81.37	2.35	0.00	79.02	79.02	79.02	00
Terrace Floor	0.00	0.00	0.00	0.00	0.00	0.00	00
Total :	162.74	4.70	54.68	103.36	103.36	103.36	01
Total Number of Same Buildings :	1						
Total :	162.74	4.70	54.68	103.36	103.36	103.36	01

SCHEDULE OF DOOR:

BUILDING NAME	NAME	LENGTH	HEIGHT	NOS
A (RESIDENTIAL)	D2	0.75	2.10	03
A (RESIDENTIAL)	D1	0.90	2.10	03
A (RESIDENTIAL)	D	1.00	2.10	02

SCHEDULE OF WINDOW/VENTILATION:

BUILDING NAME	NAME	LENGTH	HEIGHT	NOS
A (RESIDENTIAL)	V	0.60	0.90	04
A (RESIDENTIAL)	W	1.20	1.20	02
A (RESIDENTIAL)	W1	1.50	1.20	02
A (RESIDENTIAL)	Wx	2.00	1.20	01

UnitBUA Table for Building :A (RESIDENTIAL)

FLOOR	Name	UnitBUA Type	UnitBUA Area	Carpet Area	No. of Rooms	No. of Tenement
GROUND FLOOR PLAN	SPLIT BUNGALOW	FLAT	69.93	66.53	2	1
FIRST FLOOR PLAN	SPLIT BUNGALOW	FLAT	0.00	0.00	7	0
Total:	-	-	69.93	66.53	9	1

COLOR INDEX	
PLOT BOUNDARY	Black
ABUTTING ROAD	Red
PROPOSED CONSTRUCTION	Green
COMMON PLOT	Yellow
ROAD WIDENING AREA	Blue
EXISTING (To be retained)	Orange
EXISTING (To be demolished)	Purple

Buildingwise Floor FAR Details

Floor Name	Building Name		Total	
	Proposed Built Up Area (Sq.mt.)	Proposed FAR Area (Sq.mt.)	Total Proposed Built Up Area (Sq.mt.)	Total FAR Area (Sq.mt.)
Ground Floor	81.37	24.34	81.37	24.34
First Floor	81.37	79.02	81.37	79.02
Terrace Floor	0.00	0.00	0.00	0.00
Total :	162.74	103.36	162.74	103.36

Building USE/SUBUSE Details

Building Name	Building Use	Building SubUse	Building Structure
A (RESIDENTIAL)	Residential	Bungalow/ Dwelling / Non Apartment	Non-Highrise

FAR & Tenement Details (Table 4c-1)

Building	No. of Same Bldg	Total Built Up Area (Sq.mt.)	Deductions (Area in Sq.mt.)		Proposed FAR Area (Sq.mt.)	Total FAR Area (Sq.mt.)	Total Consumed Additional FAR Area (Sq.mt.)	Trmt (No.)
			Void	Parking				
A (RESIDENTIAL)	1	162.74	4.70	54.68	103.36	103.36	103.36	01
Grand Total :	1	162.74	4.70	54.68	103.36	103.36	103.36	01

LTP NAME AND SIGNATURE	STRUCTURAL ENG'S NAME AND SIGNATURE	BUILDER NAME AND SIGNATURE	DIGITAL SIGNATURE
Chandrika Sharma MNAC/DFTMN/0017/2017			

Proposal Basic Information	
Proposal File No.	MNAC/BP/0001/W09/2024
Owner Name	SMT. BINA GOSWAMI WO MR. RAJENDRA GOSWAMI
Khata No	278
Plot No	3389
Village Name	Mango
Use	Residential
SubUse	Bungalow/ Dwelling / Non Apartment

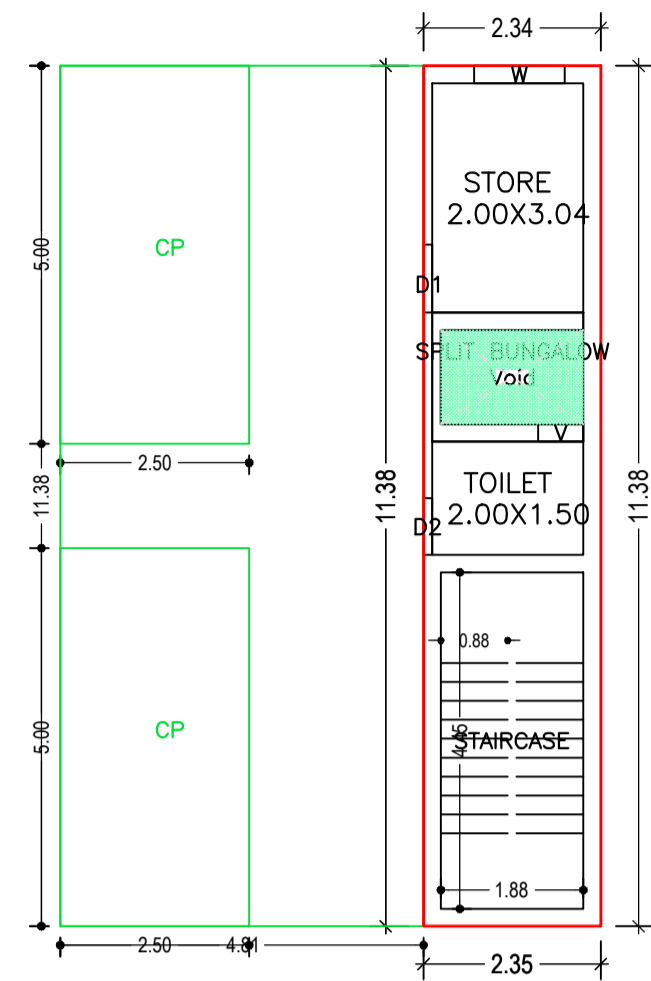

GROUND FLOOR PLAN
(Proposed)
(SCALE 1:100)

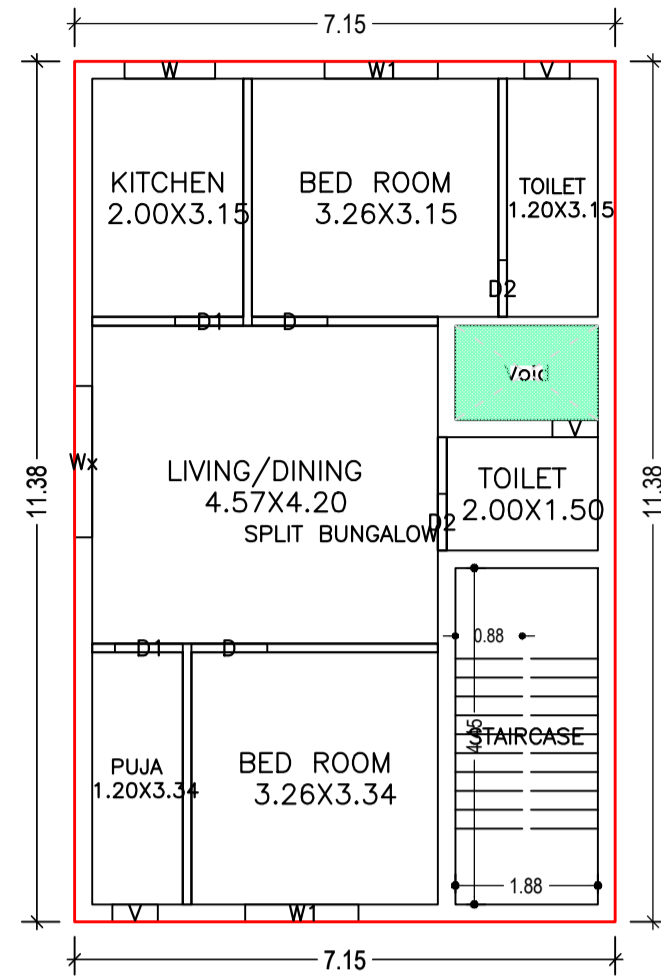

FIRST FLOOR PLAN
(Proposed)
(SCALE 1:100)

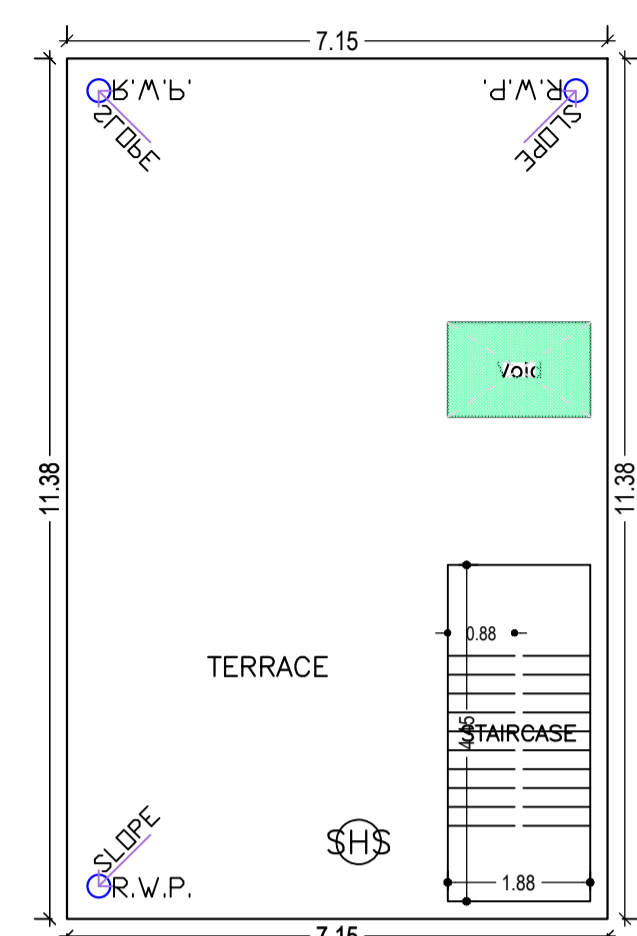

TERRACE FLOOR PLAN
(SCALE 1:100)

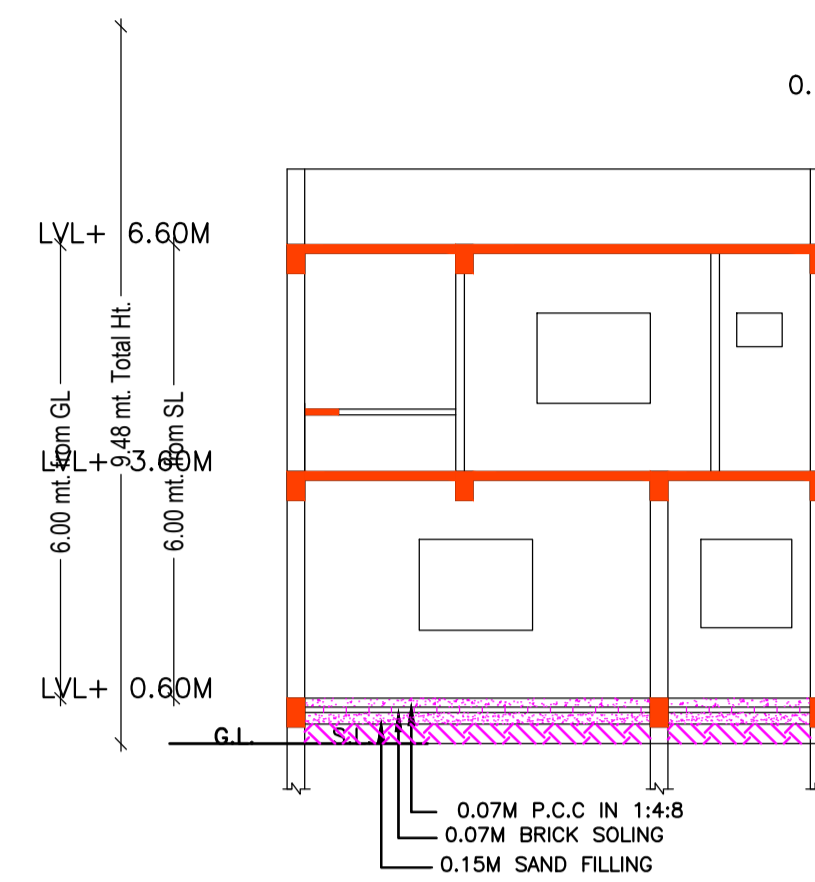

SECTION B B
SCALE 1:100

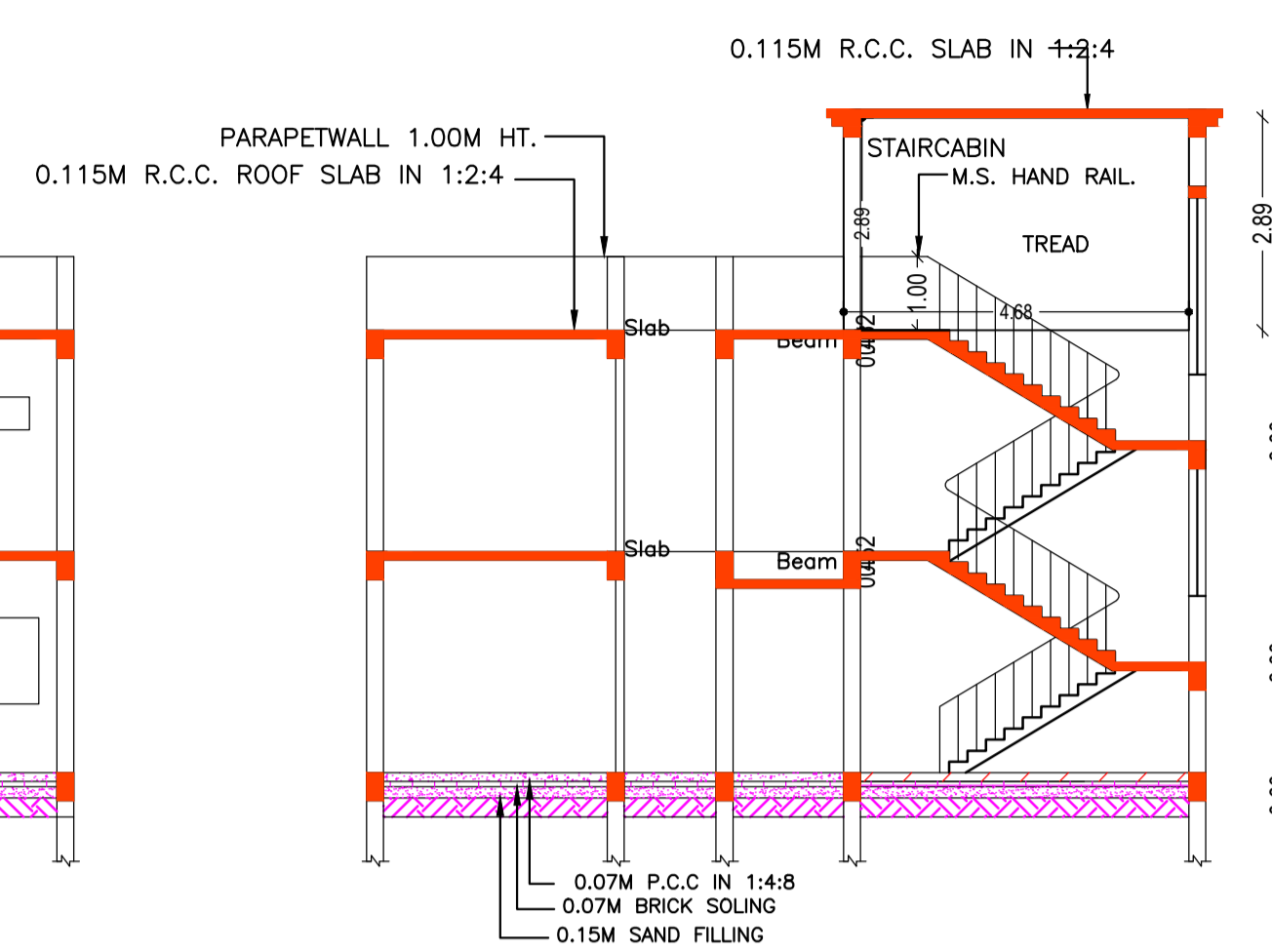

SECTION A A
SCALE 1:100

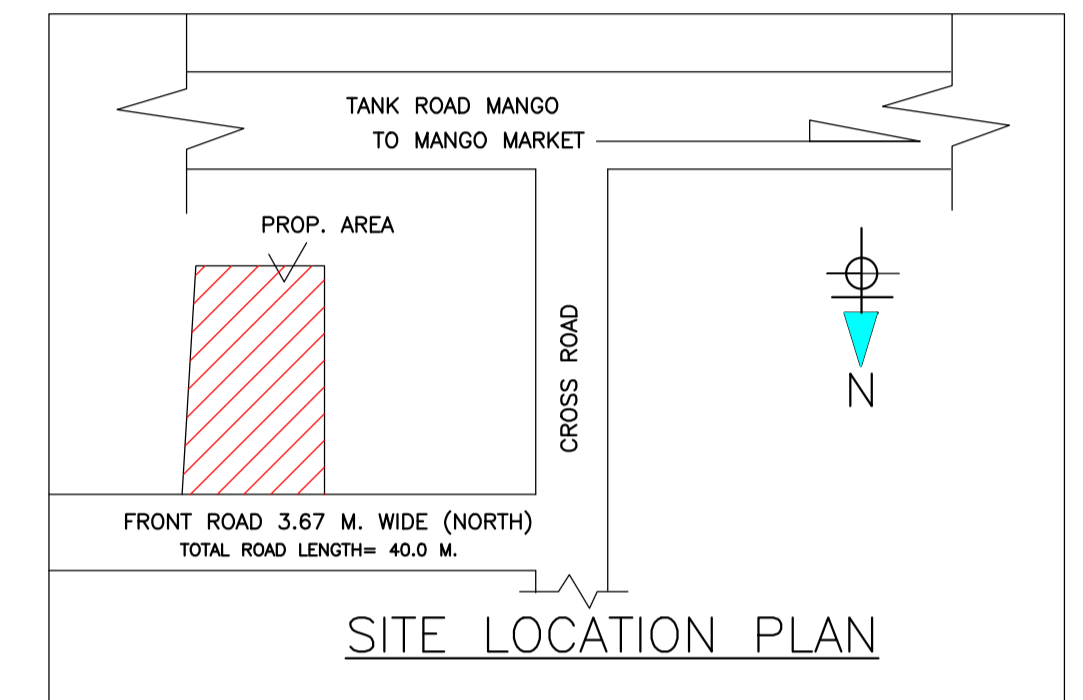

SITE LOCATION PLAN



FRONT ELEVATION
SCALE 1:100

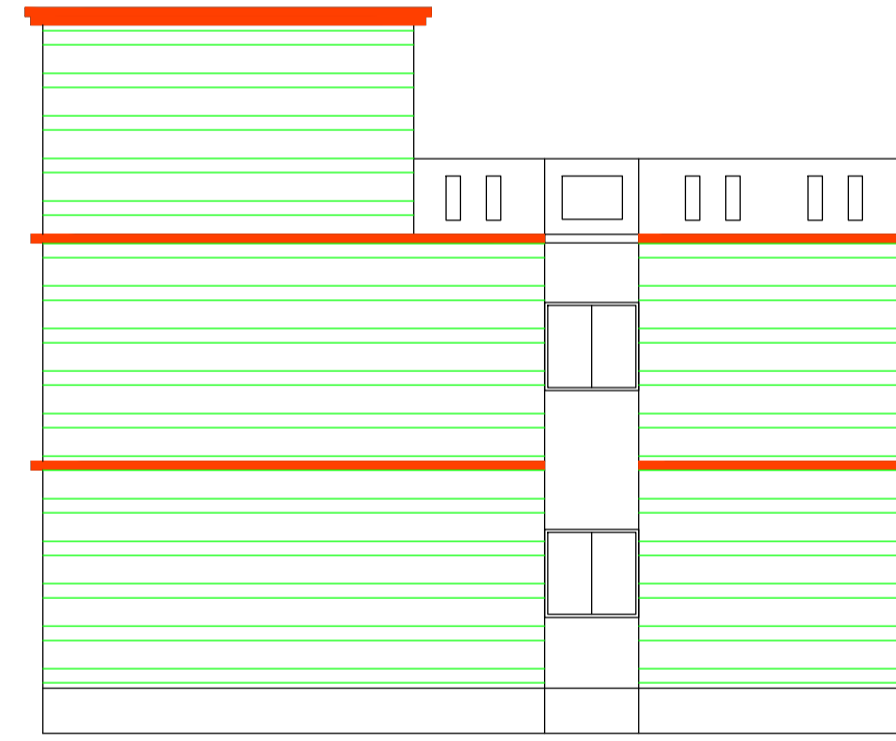

WEST SIDE ELEVATION
SCALE 1:100

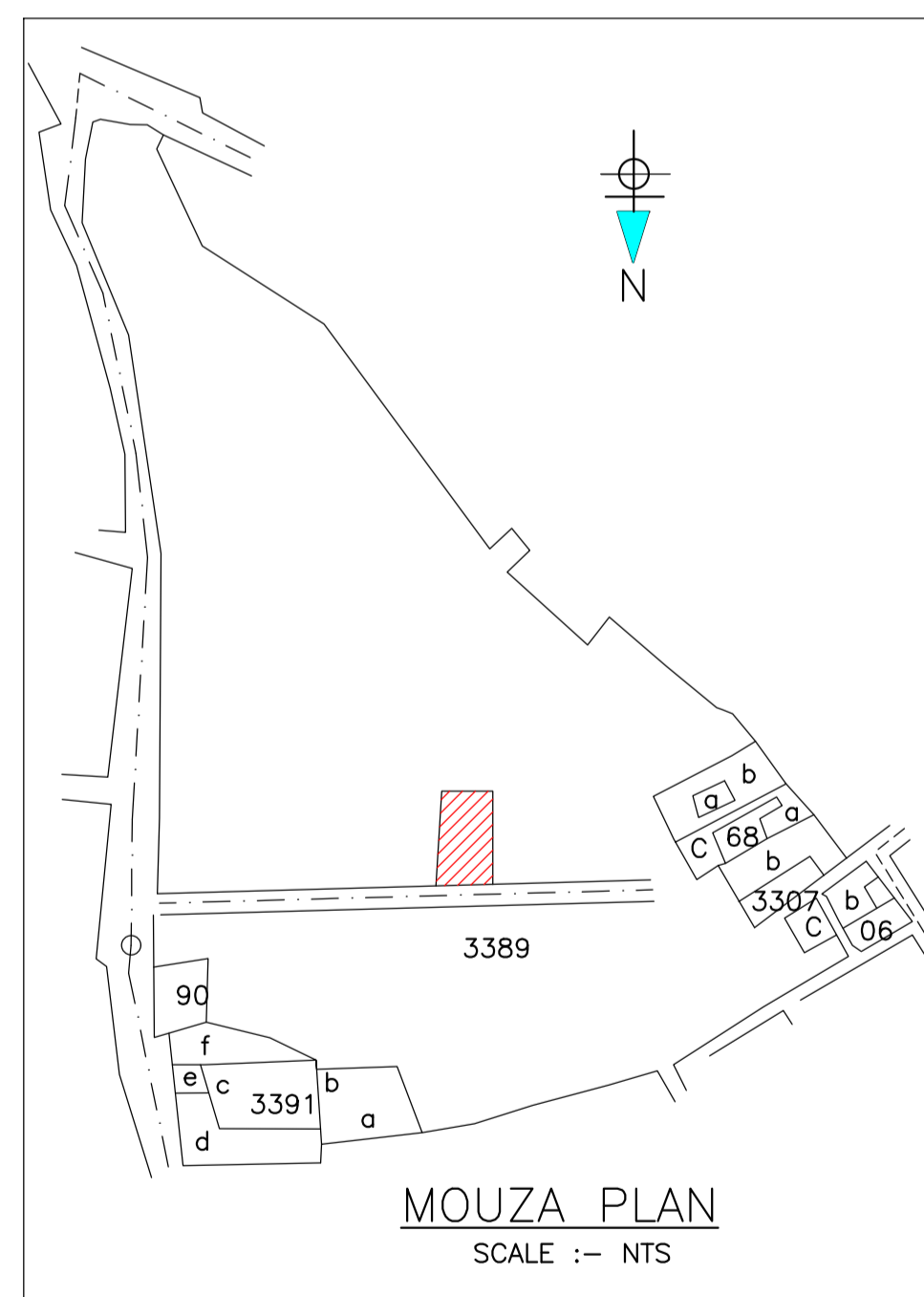

MOUZA PLAN
SCALE :- NTS

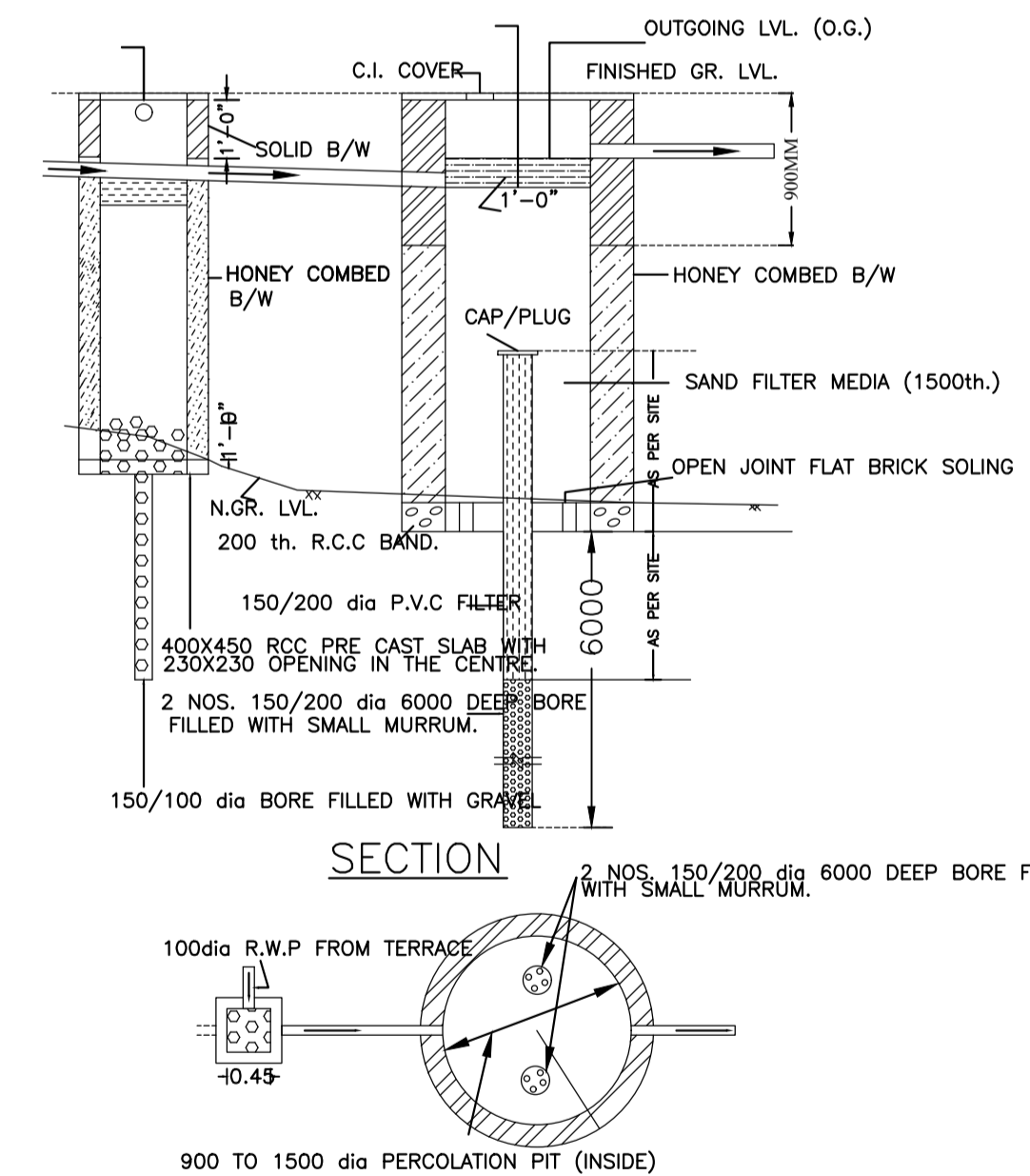

WATER HARVESTING PLAN (NTS)

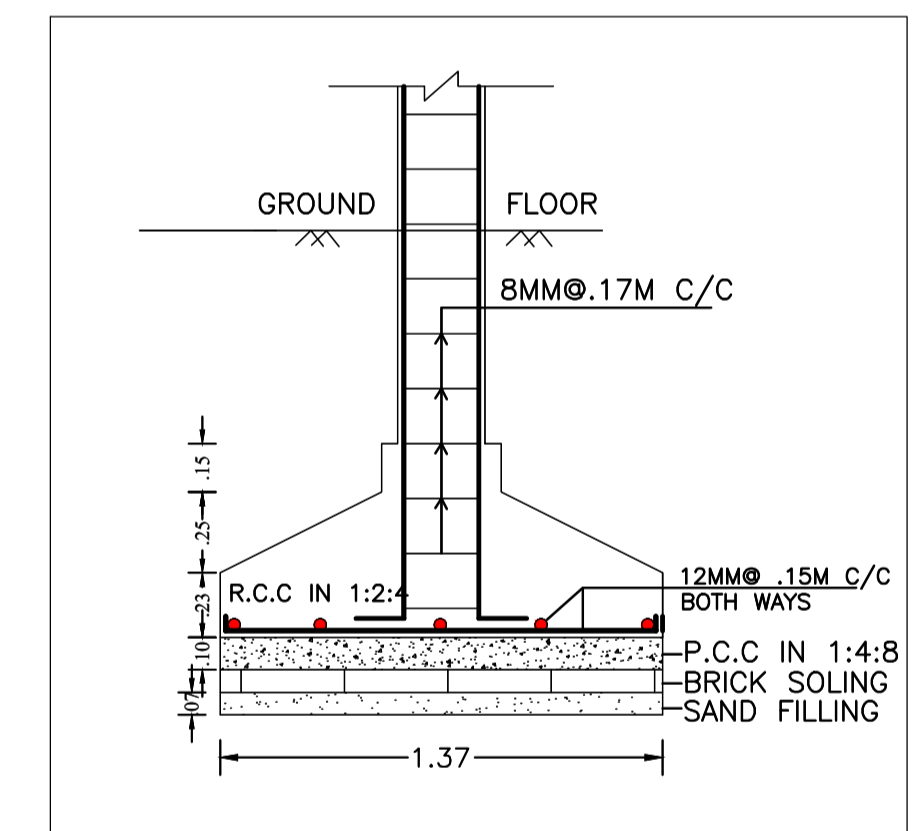

SECTION - CC
SCALE -1:25

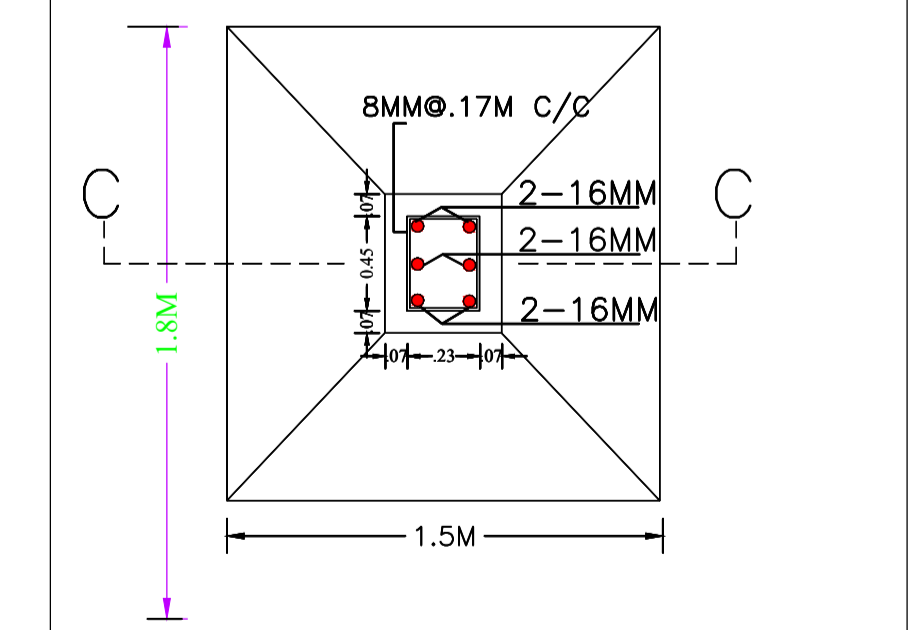

R.C.C. COL. FDN. PLAN
SCALE -1:25

LTP NAME AND SIGNATURE	STRUCTURAL ENG'S NAME AND SIGNATURE	BUILDER NAME AND SIGNATURE	DIGITAL SIGNATURE
Chandrika Sharma MNAC/DFTMN/0017/2017			