

S/No	TYPE	LENGTH	HEIGHT	SIL. LEV.	LUNTEL. LEV.	DISCRPTION
1	D1	1.20m	2.1m	0.0m	2.1m	SOLID CORE FLUSH DOOR
2	D2	0.90m	2.1m	0.0m	2.1m	SOLID CORE FLUSH DOOR
3	D3	0.80m	2.1m	0.0m	2.1m	SOLID CORE FLUSH DOOR
4	W	2.00m	1.2m	0.9m	2.1m	FULLY GLASSSED STEEL WINDOW
5	W1	1.80m	1.2m	0.9m	2.1m	FULLY GLASSSED STEEL WINDOW
6	W2	1.50m	1.2m	0.9m	2.1m	FULLY GLASSSED STEEL WINDOW
7	W3	1.20m	1.2m	0.9m	2.1m	FULLY GLASSSED STEEL WINDOW
8	W4	0.9m	1.2m	0.9m	2.1m	FULLY GLASSSED STEEL WINDOW
9	V	0.60m	0.6m	1.5m	2.1m	FULLY GLASSSED VENTILATION

Note:- this detail is applicable in all floor.

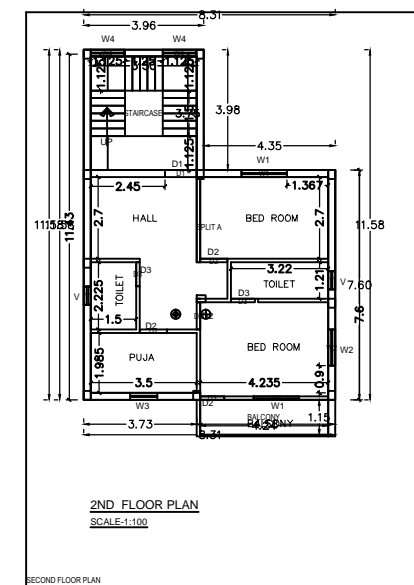
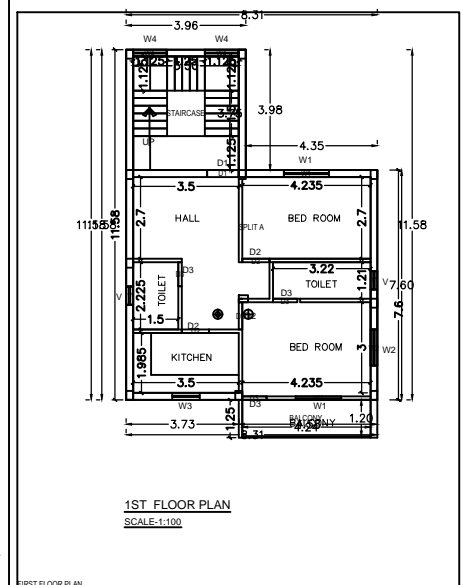
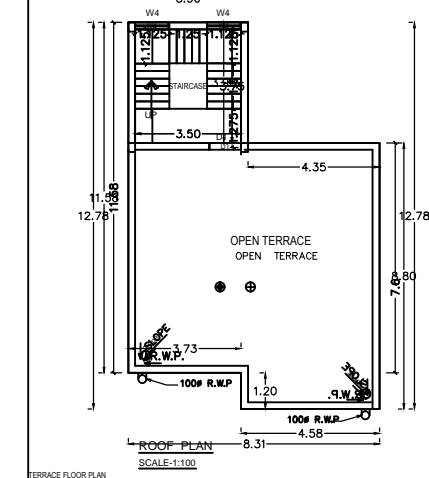
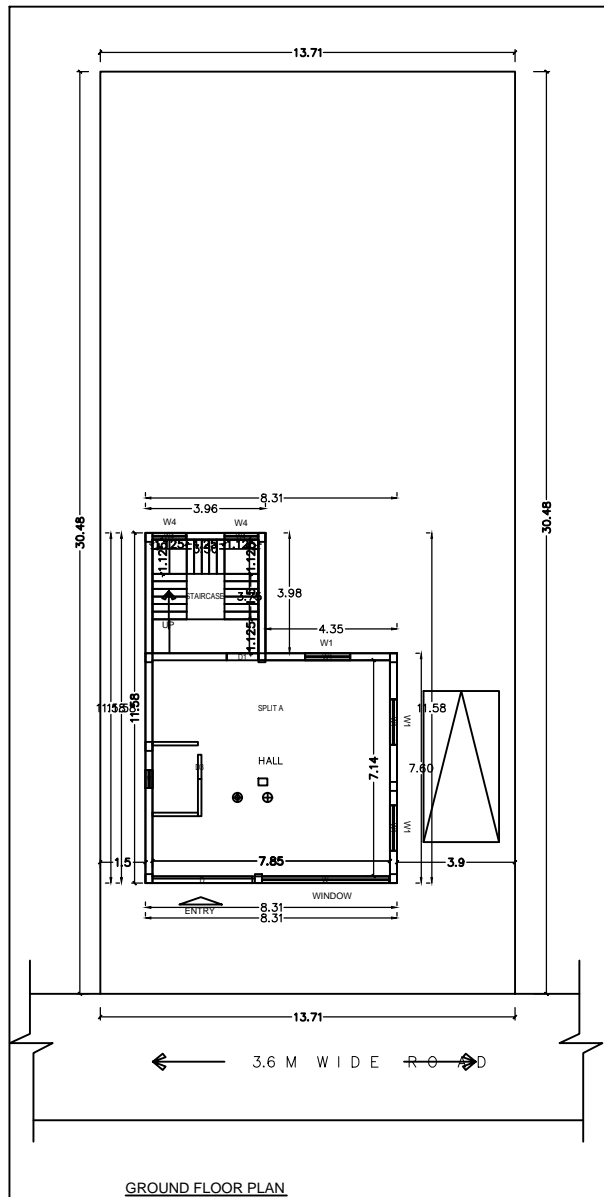
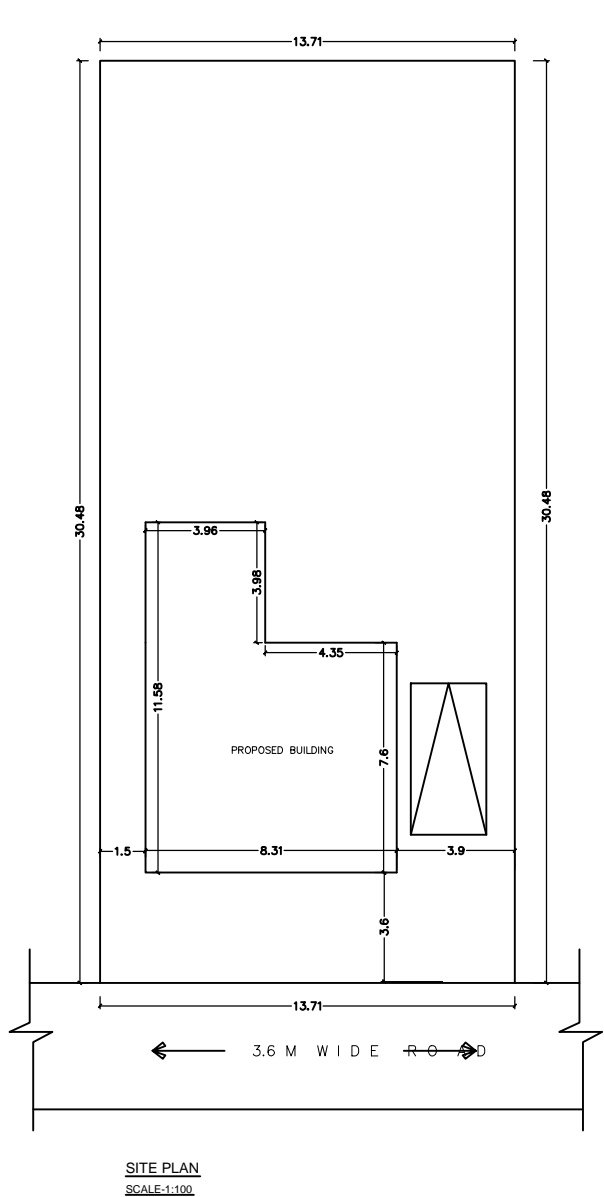
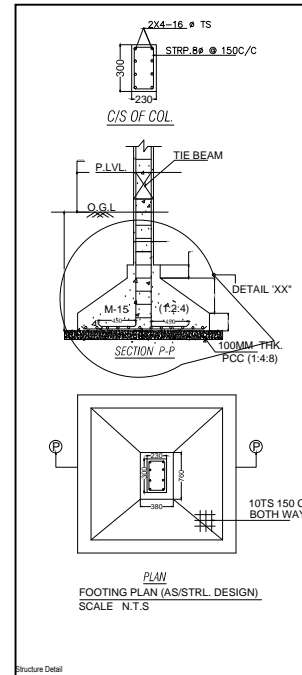
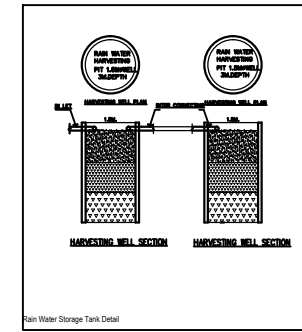

SPL.OFFICER, J.N.A.C.

PROPOSED RESIDENTIAL BUILDING PLAN OF

MANGO, JAMSHEDPUR
DISTRICT - EAST SINGHBHUM

OWNER / POAH

Signature of Applicant:-

Signature of ARCHITECT:-