

Project Title :SMT BASANTI KUMARI

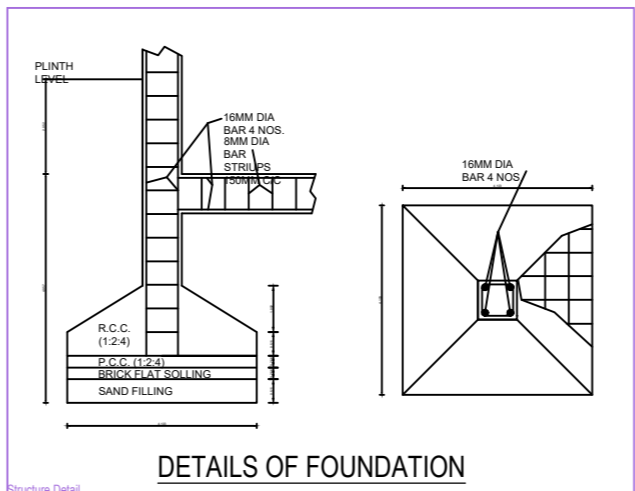
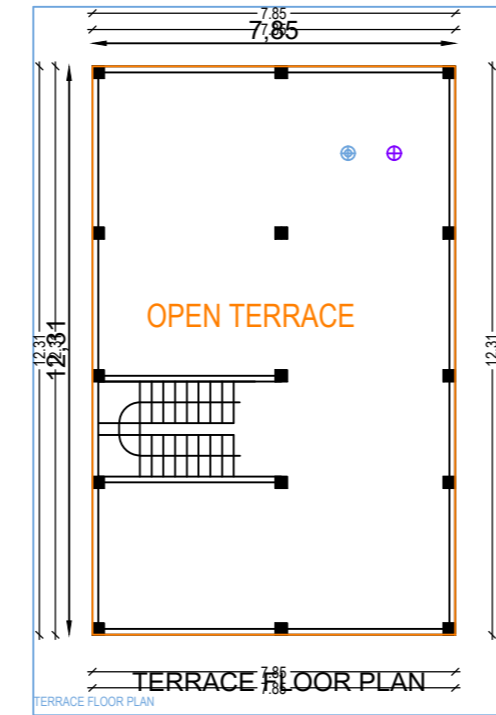
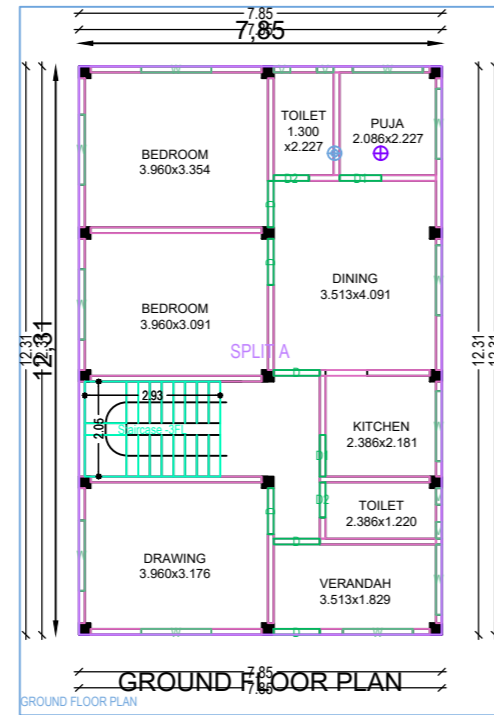
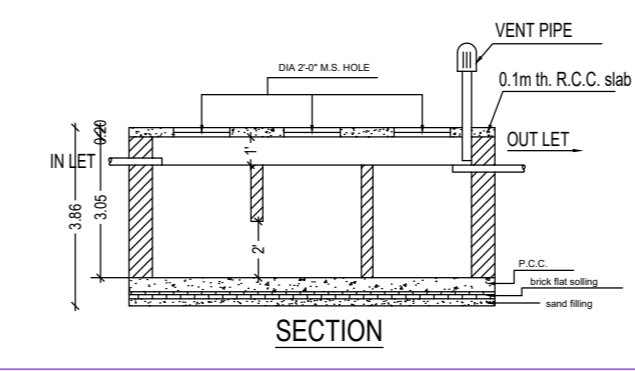
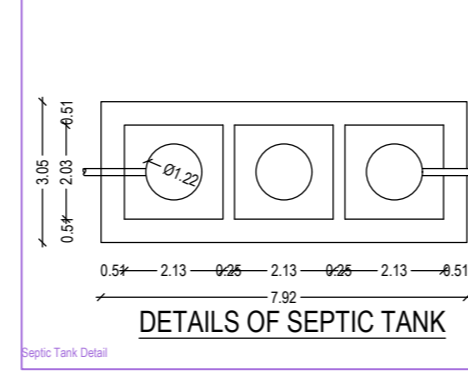
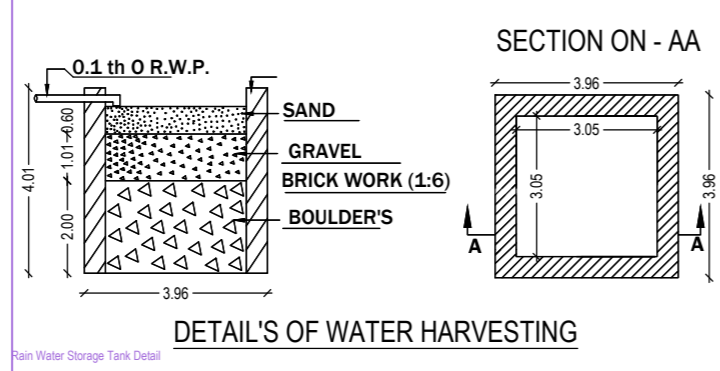
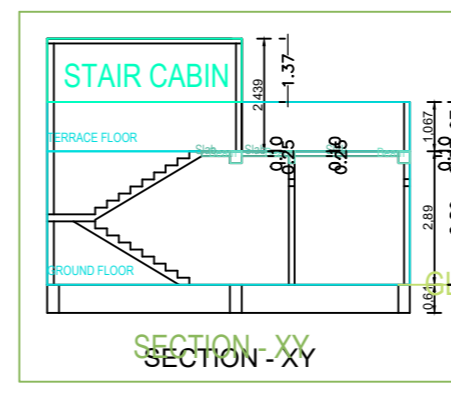
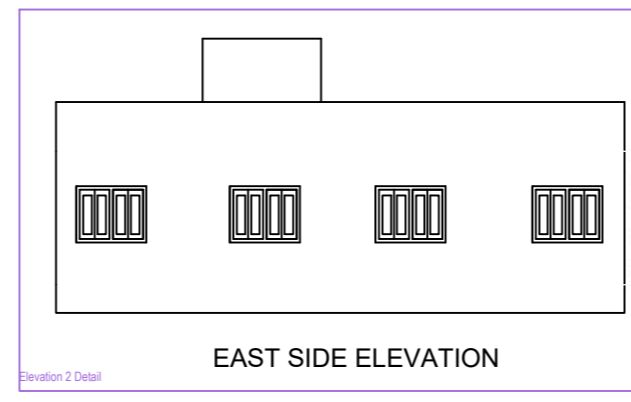
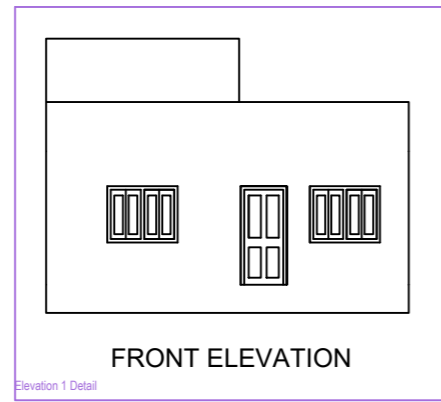
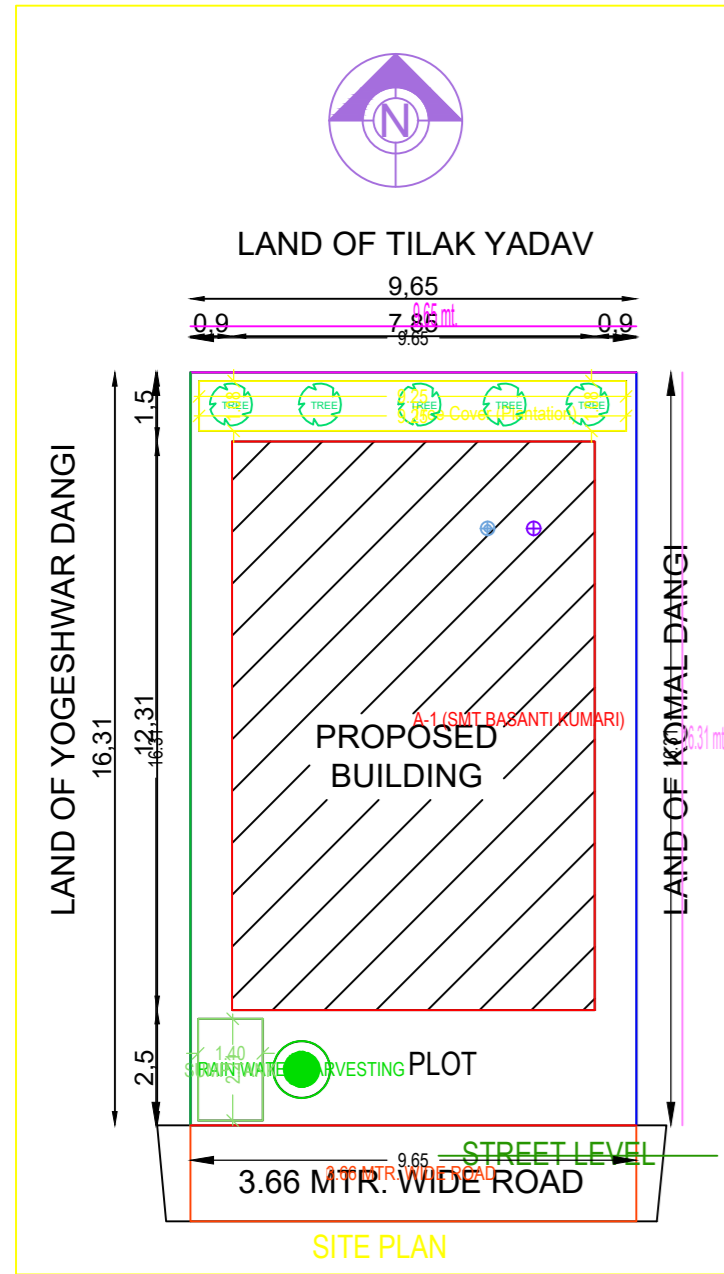

**BRIEF SPECIFICATION**  
**FOUNDATION :-** R.C.C. (1:2:4) Column footing foundation.  
**PLINTH :-** 0.30 R.C.C. (1:2:4) all round on plinth level.  
**FLOORING :-** 0.037 Marble flooring over 3<sup>th</sup> P.C.C. (1:3:6).  
**SUPER STRUCTURE :-** First class brick work in cement mortar (1:6).  
**SLAB,BEAM & LINTEL :-** All R.C.C. work (1:2:4).  
**WOOD WORK :-** All door & window frames of sal wood  
**PLASTERING :-** 12mm cement plaster (1:6) both side.

**SCHEDULE**

D - 1.00 X 2.13	W - 1.52 x 1.22
D 1 - 0.90 X 2.13	
D2 - 0.76 x 2.13	V - 0.36 x 1.00

**AREA DETAIL:-**  
 LAND AREA : 157.46 Sq.mtr. (AS PER DEED)  
 157.46 Sq.mtr. (AVAILABLE)  
 GROUND FLOOR AREA : 96.68 Sq.mtr.  
 TOTAL FLOOR AREA : 96.68 Sq.mtr.  
 COVERED AREA : 96.68 Sq.mtr.  
 F.A.R : 0.61  
 % OF PLINTH AREA : 61.40 %

**PROJECT DETAIL:-**  
 PROPOSED MAP FOR THE CONSTRUCTION OF GROUND FLOOR RESIDENTIAL BUILDING OF SMT. BASANTI KUMARI W/O SRI RAVINDRA KUMAR R/O NAGWA AT PLOT NO- 684, KHATA NO- 26, WARD NO- 21, HOLDING NO- 0210000336000M0, THANA NO- 182, MOUZA- NAGWA, UNDER CHATRA MUNICIPAL COUNCIL, CHATRA

SIGNATURE OF ENGINEER SIGNATURE OF OWNER

AREA STATEMENT: CHATRA NAGAR PRISHAD	VERSION NO.: 1.0.20
PROJECT DETAIL:	VERSION DATE: 01/01/2019
Inward No. :-	Plot Use : Residential
Region :-HARSHAN UDRIAN LOCAL BODIES	Plot SubUse : Bungalow Dwelling / Non Apartment
District : CHATRA	Land Use Zone : Residential
Application Type : General Proposal	Abutting Road Width : 3.66
Project Type : Building Permission	Plot No. : 684
Nature of Development : New	Revenue Survey No./Survey No : 182
Location : Old Area	Thana No : 182
Sub Location : NA	Holding No : 0210000336000M0
Village/Mouza Name : NAGWA	Khata No : 26
Ward No : 21	North : -
Road/Street : NAGWA	South : -
	East : -
	West : -

AREA DETAILS :		SQ.MT.
AREA OF PLOT (Minimum)	(A)	157.46
Net Plot Area (Gross Plot Area - Deductions from Gross Plot area)	(A-Deductions)	157.46
Deductions for Balance Plot Area (from Gross Plot Area)		
COP Area		9.98
Total		9.98
Balance Plot Area (Net Plot Area - Recreational/Amenity space)	(A-Deductions)	147.48
Plot Area for Coverage (Net Plot Area)	(A-Deductions)	157.46
Plot Area for FSI (Net Plot Area + Road/Widening Area)	(A-Deductions)	157.46
COVERAGRE CHECK		
Proposed Coverage Area ( - % )		0.00
Total Coverage Area (0.00 % )		0.00
FAR CHECK		
Proposed Area of FAR		96.68
Total Area of FAR		96.68
BUILT UP AREA CHECK		
Total Proposed Building Area		96.68
ARCH / ENSG / SUPERVISOR (Regd)		OWNER
DEVELOPMENT AUTHORITY		LOCAL BODY

**COLOR INDEX**

PLOT BOUNDARY	Black
ABUTTING ROAD	Green
PROPOSED WORK (COVERAGE AREA)	Red
EXISTING (To be retained)	Blue
EXISTING (To be demolished)	Yellow

**MARGIN DETAIL:**

Building / Wing Name	Road Name	Front Margin	Rear Margin	Side1 Margin	Side2 Margin
A-1 (SMT BASANTI KUMARI)	3.66 MTR. WIDE ROAD	2.50	1.50	0.90	0.90

**FAR & Tenement Details (Table 4c-1)**

Building	No. of Same Bldg	Total Built Up Area (Sq.mt.)	Proposed FAR Area (Sq.mt.) Res.	Total FAR Area (Sq.mt.)	Tnmt (No.)
A (SMT BASANTI KUMARI)	1	96.68	96.68	96.68	01
Grand Total :	1	96.68	96.68	96.68	01

A (SMT BASANTI KUMARI)

Building 'A' (SMT BASANTI KUMARI)

Floor Name	Total Built Up Area (Sq.mt.)	Proposed FAR Area (Sq.mt.) Res.	Total FAR Area (Sq.mt.)	Tnmt (No.)
Ground Floor	96.68	96.68	96.68	01
Terrace Floor	0.00	0.00	0.00	00
Total	96.68	96.68	96.68	01
Total Number of Same Buildings	1			
Total	96.68	96.68	96.68	01

SCHEDULE OF JOINERY:

BUILDING NAME	NAME	LENGTH	HEIGHT	NOS
A (SMT BASANTI KUMARI)	D2	0.76	2.13	02
A (SMT BASANTI KUMARI)	D1	0.90	2.13	02
A (SMT BASANTI KUMARI)	D	1.00	2.13	06
Total	-	-	-	10

SCHEDULE OF JOINERY:

BUILDING NAME	NAME	LENGTH	HEIGHT	NOS
A (SMT BASANTI KUMARI)	V	0.36	1.00	04
A (SMT BASANTI KUMARI)	W	1.52	1.22	11
Total	-	-	-	15

UnitBUA Table for Building 'A' (SMT BASANTI KUMARI)

FLOOR	Name	UnitBUA Type	UnitBUA Area	Carpet Area	No. of Rooms	No. of Tenement
GROUND FLOOR PLAN	SPLIT A	FLAT	96.68	87.18	9	1
Total	-	-	96.68	87.18	9	1