

FAR & Tenement Details (Table 4c-1)

Building	No. of Same Bldg	Total Built Up Area (Sq.mt.)	Proposed FAR Area (Sq.mt.) Resi.	Total FAR Area (Sq.mt.)	Total Consumed Additional FAR Area (Sq.mt.)	Tnmt (No.)
A (SMT SWETA KIRAN)	1	76.04	76.04	76.04	76.04	01
Grand Total :	1	76.04	76.04	76.04	76.04	01

Proposal Basic Information

Proposal File No.	CHNP/BP/0012/W11/2019
Owner Name	SWETA KIRAN
Khata No	48
Plot No	203
Village Name	Chatra
Use	Residential
SubUse	Bungalow/ Dwelling / Non Apartment

AREA STATEMENT CHATRA NAGAR PRISHAD	VERSION NO: 1.0.44	SQ.MT.
PROJECT DETAIL:	VERSION DATE: 29/04/2019	
Region: JHARKHAND URBAN LOCAL BODIES	Plot Use: Residential	
District: CHATRA	Plot SubUse: Bungalow/ Dwelling / Non Apartment	
Authority: CHATRA NAGAR PRISHAD	PlotNearbyReligiousStructure: NA	
Inward_No: CHNP/BP/0012/W11/2019	PlotSubPlot No: 203	
Application Type: General Proposal	North: Plot No. - upender kumar	
Project Type: Building Permission	South: Plot No. - ramesh chandire	
Nature of Development: New	East: Road Width - road	
Location of Development Area: Old Area	West: Road Width - road	
AREA DETAILS:		
AREA OF PLOT (Minimum)	(A)	120.57
Deduction for NetPlot Area		
Surrender Free of Cost		5.17
Total		5.17
NET AREA OF PLOT(Gross Plot Area - Deduction from Gross Plot area)	(A-Deductions)	115.41
Deduction for Balance Plot Area(from Gross Plot Area)		
Surrender Free of Cost		5.17
Common Plot		12.43
Total		17.60
BALANCE AREA OF PLOT(Net Plot Area - Recreational/Amenity space)	(A-Deductions)	102.98
PLOT AREA FOR COVERAGE(Net Plot Area)	(A-Deductions)	115.41
Plot Area for FAR (Net Plot Area + RoadWidening Area)	(A-Deductions)	120.57
COVERAGE CHECK		
Permissible Coverage area (70.00 %)		80.79
Proposed Coverage Area (65.89 %)		76.04
Total Prop. Coverage Area (65.89 %)		76.04
Balance coverage area (4.12 %)		4.75
FAR CHECK		
Perm. FAR Area (1.50)		180.85
Total Perm. FAR area		180.85
Residential FAR		76.04
Proposed FAR Area		76.04
Total Proposed FAR Area		76.04
Consumed FAR (Factor)		0.63
Balance FAR Area		104.81
BUILT UP AREA CHECK		
Total Proposed BuiltUp Area		76.04
ARCHITECT (Regd)	LAW CHATURVEDI	
ENGINEER (Regd)		
SUPERVISOR (Regd)		
OWNER (Regd)	SWETA KIRAN	
DEVELOPMENT AUTHORITY	LOCAL BODY	

COLOR INDEX	
PLOT BOUNDARY	Black
ABUTTING ROAD	Green
PROPOSED CONSTRUCTION	Red
COMMON PLOT	Yellow
ROAD WIDENING AREA	Blue
EXISTING (To be retained)	Blue
EXISTING (To be demolished)	Yellow

Buildingwise Floor FAR Details

Floor Name	Building Name A (SMT SWETA KIRAN)		Total	
	Proposed Built Up Area (Sq.mt.)	Proposed FAR Area (Sq.mt.)	Total Proposed Built Up Area (Sq.mt.)	Total FAR Area (Sq.mt.)
Ground Floor	76.04	76.04	76.04	76.04
Terrace Floor	0.00	0.00	0.00	0.00
Total :	76.04	76.04	76.04	76.04

Building USE/SUBUSE Details

Building Name	Building Use	Building SubUse	Building Structure
A (SMT SWETA KIRAN)	Residential	Bungalow/ Dwelling / Non Apartment	Non-Highrise

LTP NAME AND SIGNATURE	STRUCTURAL ENG'S NAME AND SIGNATURE	BUILDER NAME AND SIGNATURE	DIGITAL SIGNATURE
LAW CHATURVEDI CHNP/ENG/0004/2017			

Proposal Basic Information	
Proposal File No.	CHNP/BP/0012/W11/2019
Owner Name	SWETA KIRAN
Khata No	48
Plot No	203
Village Name	Chatra
Use	Residential
SubUse	Bungalow/ Dwelling / Non Apartment

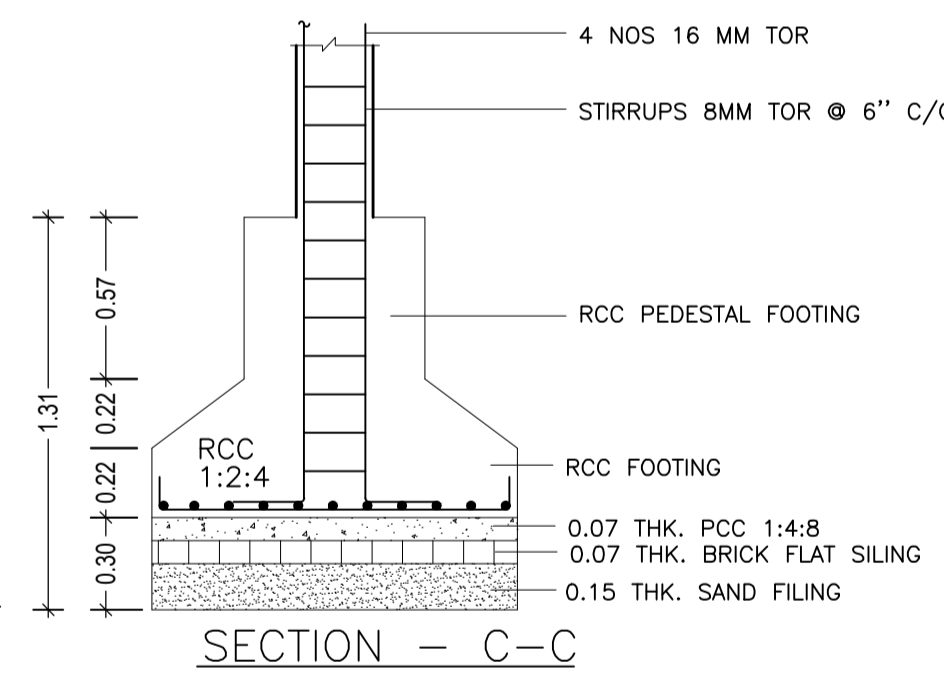
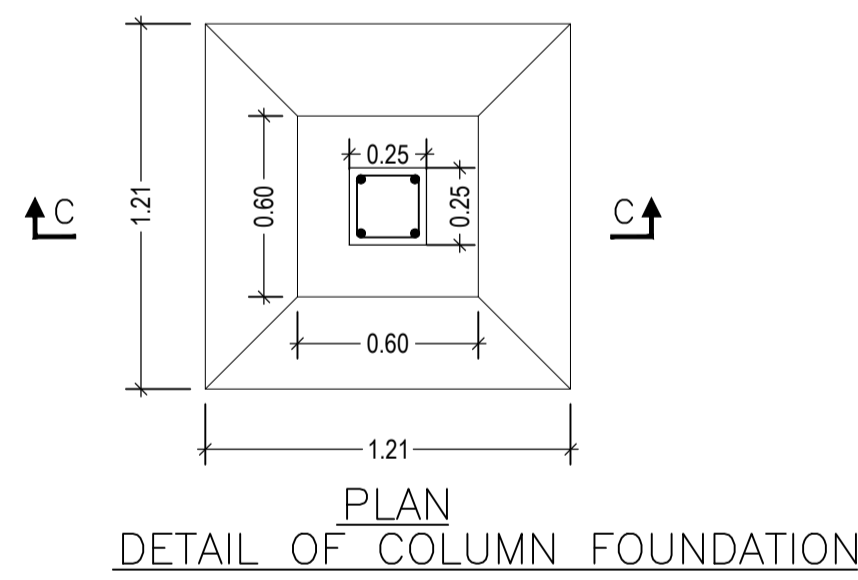
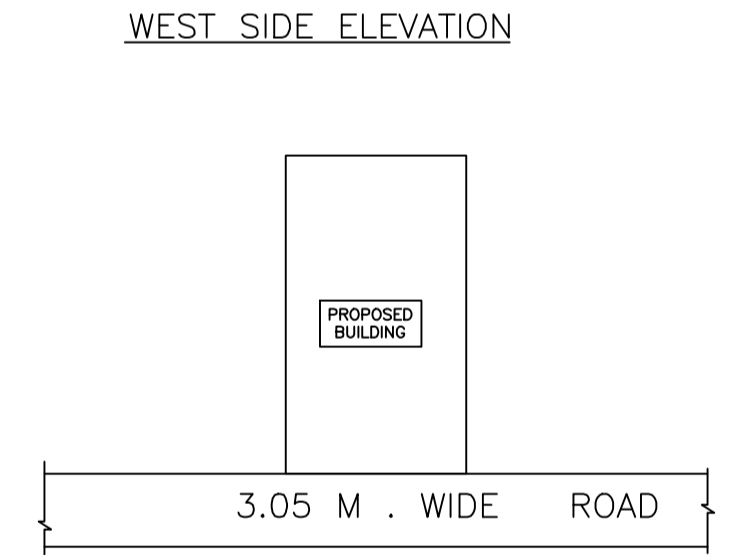
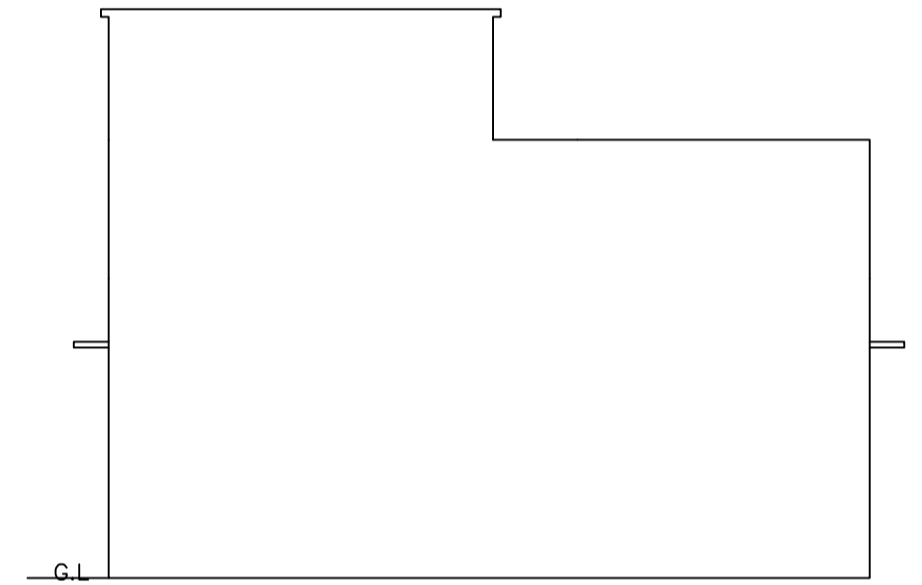
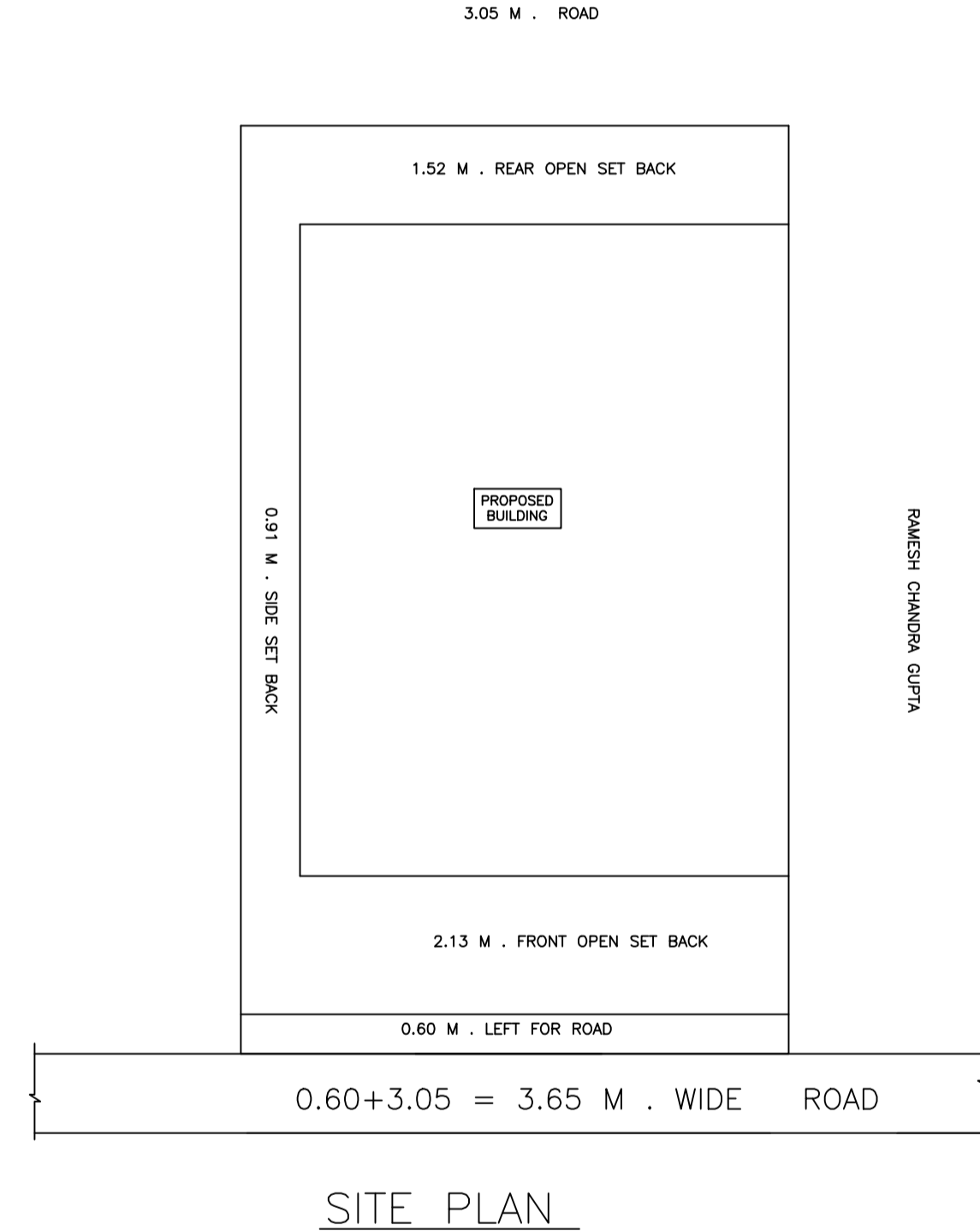
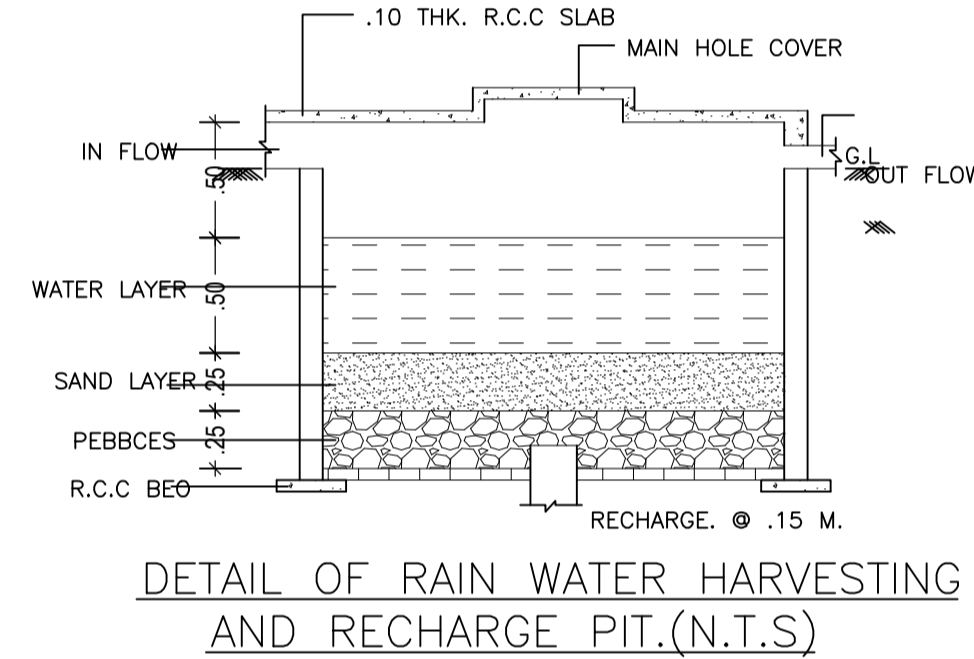
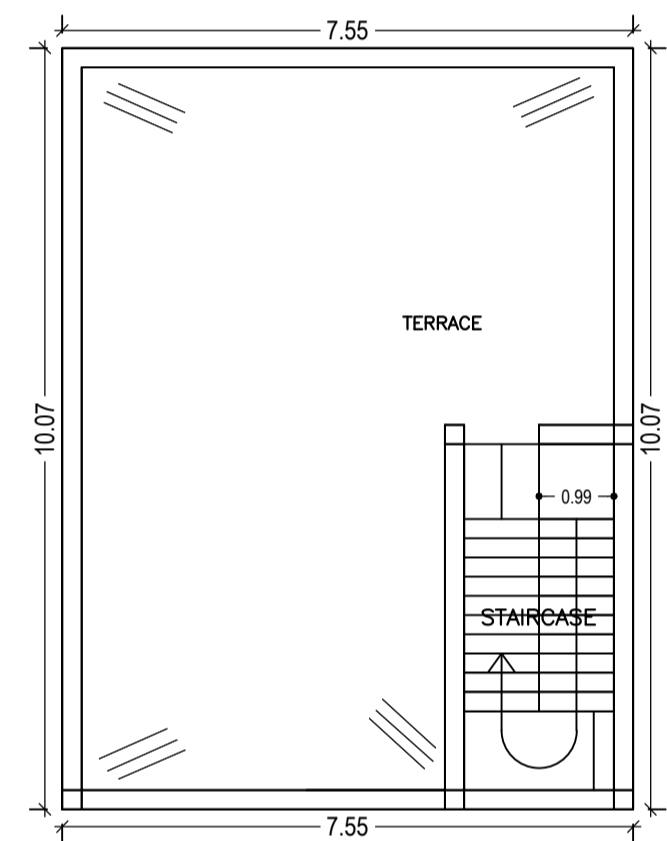
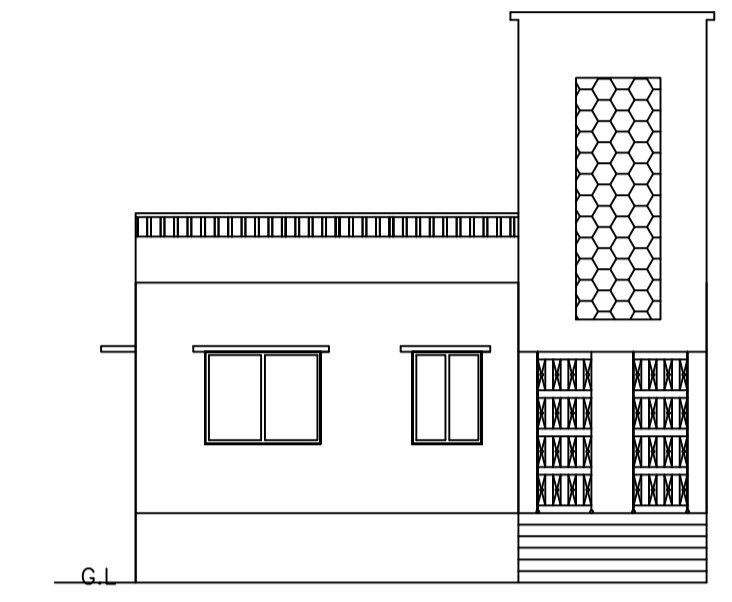
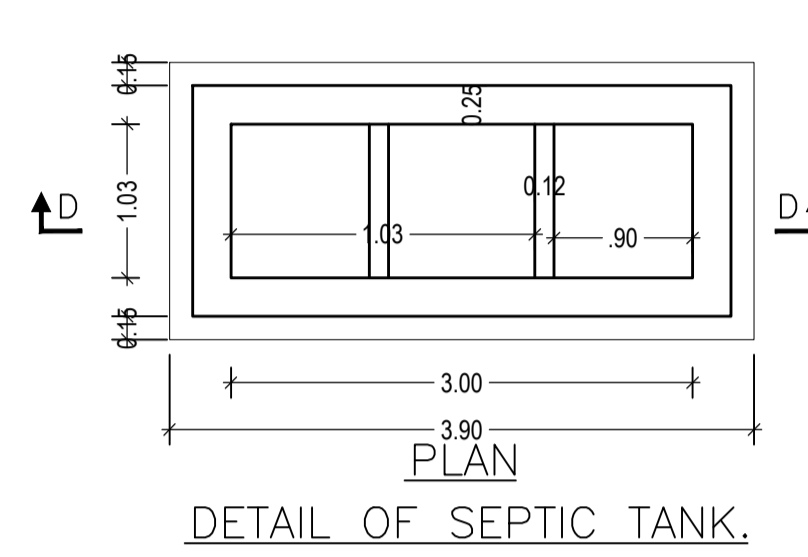
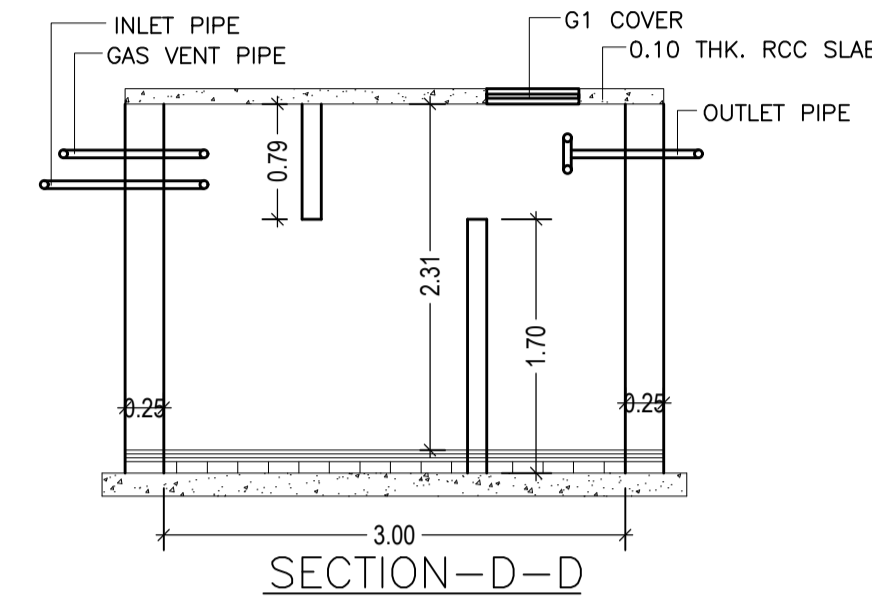
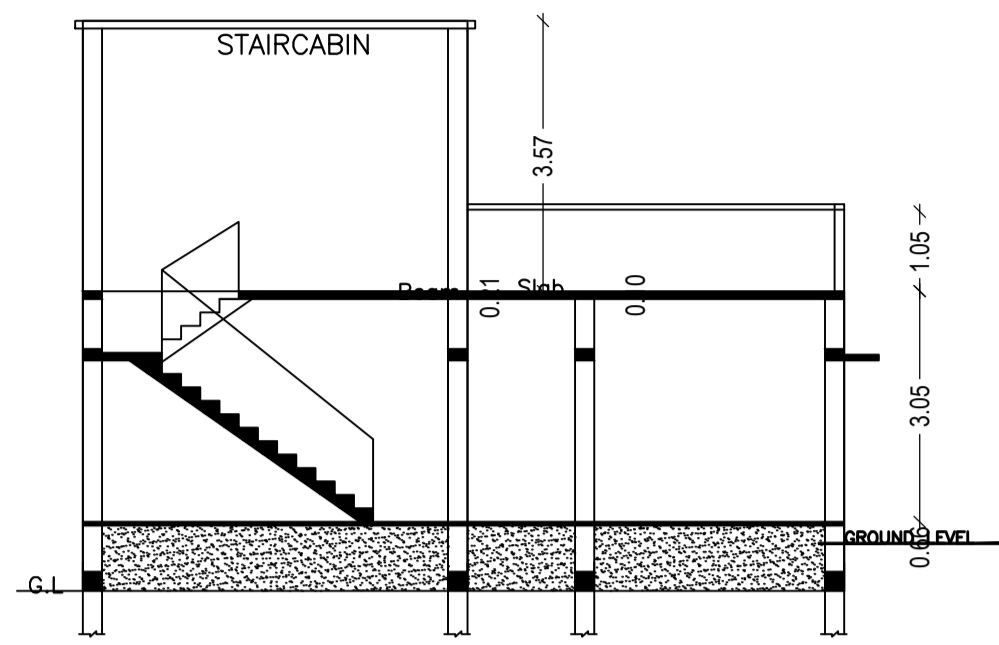
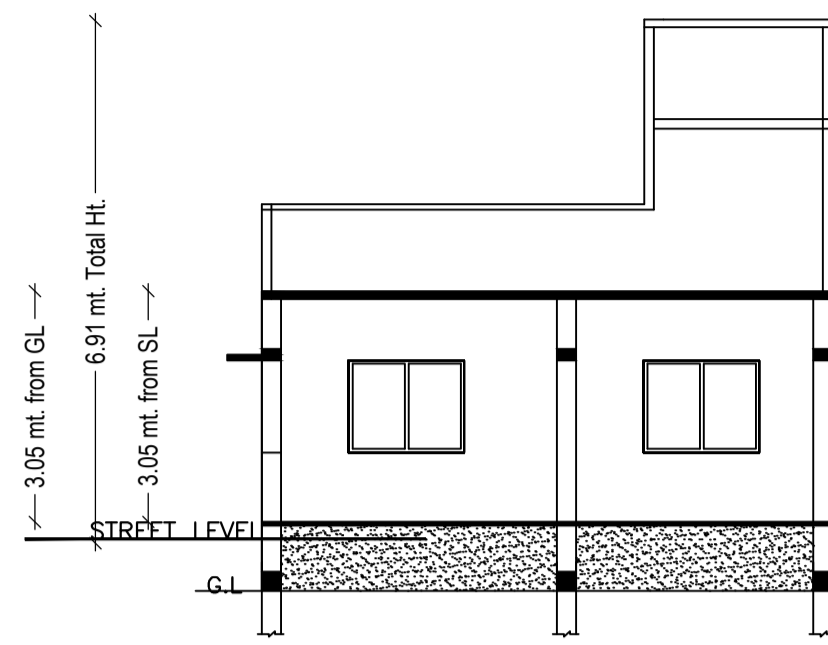
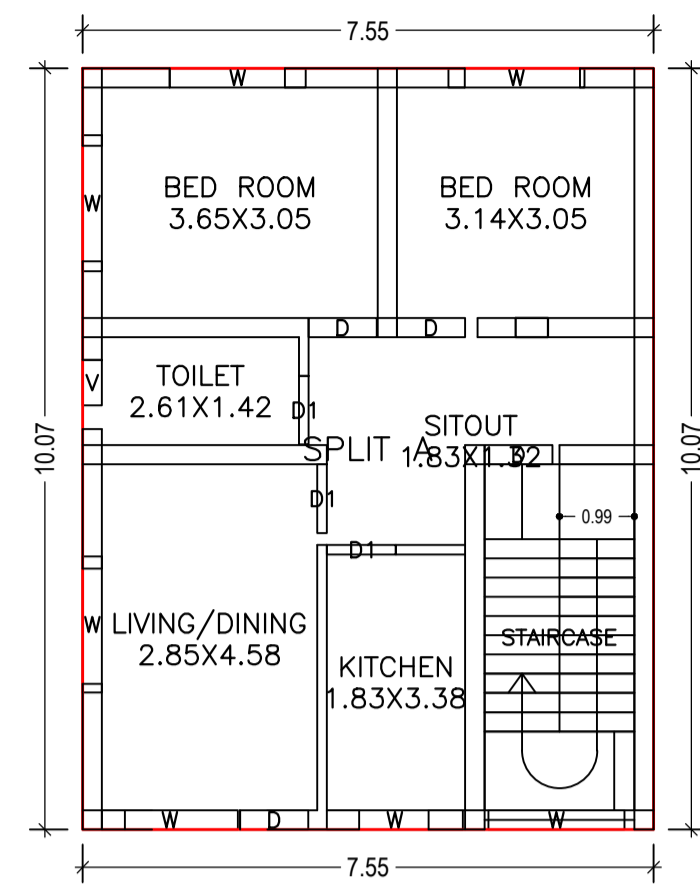

Building :A (SMT SWETA KIRAN)

Floor Name	Total Built Up Area (Sq.mt.)	Proposed FAR Area (Sq.mt.)	Total FAR Area (Sq.mt.)	Total Consumed Additional FAR Area (Sq.mt.)	Tnmt (No.)
Ground Floor	76.04	76.04	76.04	76.04	01
Terrace Floor	0.00	0.00	0.00	0.00	00
Total:	76.04	76.04	76.04	76.04	01
Total Number of Same Buildings	1				
Total:	76.04	76.04	76.04	76.04	01

SCHEDULE OF DOOR:

BUILDING NAME	NAME	LENGTH	HEIGHT	NOS
A (SMT SWETA KIRAN)	D	0.90	2.13	04
A (SMT SWETA KIRAN)	D1	0.91	2.13	03

SCHEDULE OF WINDOW/VENTILATION:

BUILDING NAME	NAME	LENGTH	HEIGHT	NOS
A (SMT SWETA KIRAN)	V	0.60	2.70	01
A (SMT SWETA KIRAN)	W	1.80	2.70	07

UnitBUA Table for Building :A (SMT SWETA KIRAN)

FLOOR	Name	UnitBUA Type	UnitBUA Area	Carpet Area	No. of Rooms	No. of Tenement
GROUND FLOOR PLAN	SPLIT A	FLAT	56.52	56.42	6	1
Total:	-	-	56.52	56.42	6	1

LTP NAME AND SIGNATURE	STRUCTURAL ENG'S NAME AND SIGNATURE	BUILDER NAME AND SIGNATURE	DIGITAL SIGNATURE
LAW CHATURVEDI CHNP/ENG/0004/2017			