

Proposal Basic Information	
Proposal File No.	CHNP/BP/0014/W03/2021
Owner Name	PRITI DEVI
Khata No	244
Plot No	131
Village Name	Chatra
Use	Residential
SubUse	Bungalow/ Dwelling / Non Apartment

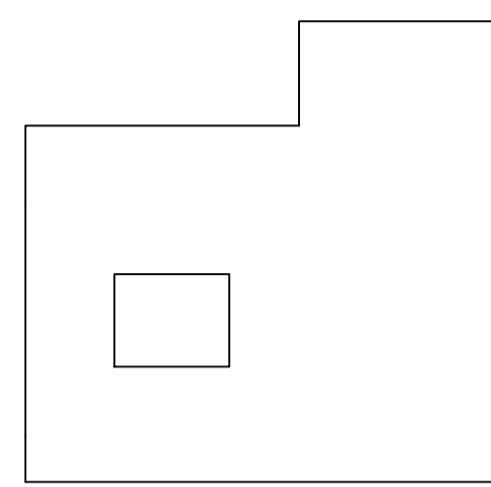

FRONT ELEVATION

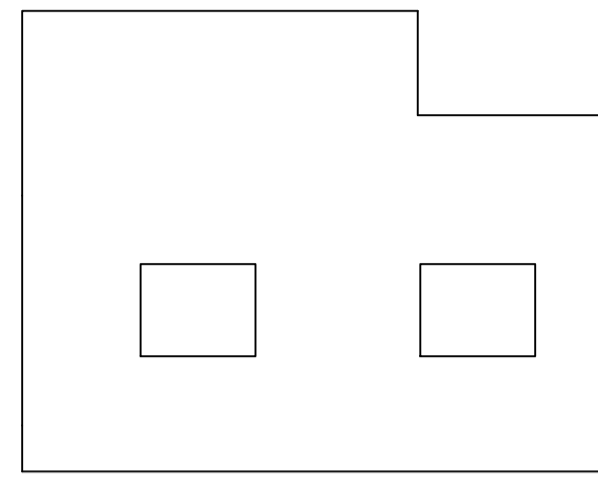

NORTH SIDE ELEVATION

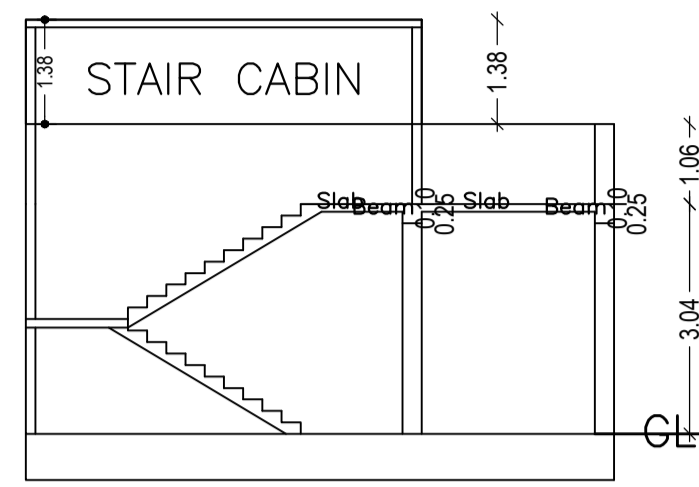

SECTION - XY

Buildingwise Floor FAR Details

Floor Name	Building Name A (SMT PRITI DEVI)		Total	
	Proposed Built Up Area (Sq.mt.)	Proposed FAR Area (Sq.mt.)	Total Proposed Built Up Area (Sq.mt.)	Total FAR Area (Sq.mt.)
Ground Floor	48.70	48.70	48.70	48.70
Terrace Floor	0.00	0.00	0.00	0.00
Total :	48.70	48.70	48.70	48.70

COLOR INDEX	
PLOT BOUNDARY	Black
ABUTTING ROAD	Green
PROPOSED CONSTRUCTION	Red
COMMON PLOT	Yellow
ROAD WIDENING AREA	Orange
EXISTING (To be retained)	Blue
EXISTING (To be demolished)	Light Blue

SCHEDULE OF DOOR:

BUILDING NAME	NAME	LENGTH	HEIGHT	NOS
A (SMT PRITI DEVI)	D2	0.76	2.13	01
A (SMT PRITI DEVI)	D1	0.90	2.13	01
A (SMT PRITI DEVI)	D	1.00	2.13	01

FAR & Tenement Details (Table 4c-1)

Building	No. of Same Bldg	Total Built Up Area (Sq.mt.)	Proposed FAR Area (Sq.mt.) Resi.	Total FAR Area (Sq.mt.)	Total Consumed Additional FAR Area (Sq.mt.)	Tnmt (No.)
A (SMT PRITI DEVI)	1	48.70	48.70	48.70	48.70	01
Grand Total :	1	48.70	48.70	48.70	48.70	01

SCHEDULE OF WINDOW/VENTILATION:

BUILDING NAME	NAME	LENGTH	HEIGHT	NOS
A (SMT PRITI DEVI)	V	0.36	1.00	02
A (SMT PRITI DEVI)	W	1.52	1.22	03

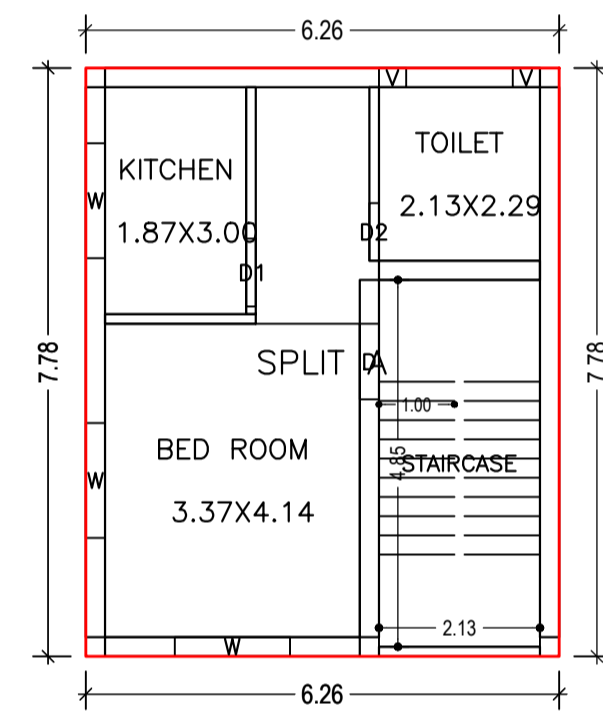

GROUND FLOOR PLAN (Proposed) (SCALE 1:100)

Building :A (SMT PRITI DEVI)

Floor Name	Total Built Up Area (Sq.mt.)	Proposed FAR Area (Sq.mt.) Resi.	Total FAR Area (Sq.mt.)	Total Consumed Additional FAR Area (Sq.mt.)	Tnmt (No.)
Ground Floor	48.70	48.70	48.70	48.70	01
Terrace Floor	0.00	0.00	0.00	0.00	00
Total :	48.70	48.70	48.70	48.70	01
Total Number of Same Buildings	1				
Total :	48.70	48.70	48.70	48.70	01

UnitBUA Table for Building :A (SMT PRITI DEVI)

FLOOR	Name	UnitBUA Type	UnitBUA Area	Carpet Area	No. of Rooms	No. of Tenement
GROUND FLOOR PLAN	SPLIT A	FLAT	48.70	39.75	3	1
Total:	-	-	48.70	39.75	3	1

AREA STATEMENT CHATRA NAGAR PRISHAD		VERSION NO.: 1.0.60
PROJECT DETAIL:		VERSION DATE: 16/10/2020
Region: JHARKHAND URBAN	Plot Use: Residential	
LOCAL BODIES	Plot SubUse: Bungalow/ Dwelling / Non Apartment	
District: CHATRA	PlotNearbyReligiousStructure: NA	
Authority: CHATRA NAGAR PRISHAD	PlotNearbyReligiousStructure: NA	
Inward_No: CHNP/BP/0014/W03/2021	Plot/SubPlot No: 131	
Application Type: General Proposal	North: Plot No. - NIZ VENDER	
Project Type: Building Permission	South: Plot No. - NIZ VENDER	
Nature of Development: New	East: Plot No. - POONAM DEVI	
Location of Development Area: Old Area	West: Road Width - ROAD	
AREA DETAILS:		
AREA OF PLOT (Minimum)	(A)	80.76 SQ.MT.
NET AREA OF PLOT(Gross Plot Area - Deduction from Gross Plot area)	(A-Deductions)	80.76
Deduction for Balance Plot Area(from Gross Plot Area)		
Common Plot		6.41
Total		6.41
BALANCE AREA OF PLOT(Net Plot Area - Recreational/Amenity space)	(A-Deductions)	74.35
PLOT AREA FOR COVERAGE(Net Plot Area)	(A-Deductions)	80.76
Plot Area for FAR (Net Plot Area + RoadWidening Area)	(A-Deductions)	80.76
COVERAGE CHECK		
Permissible Coverage area ( 70.00 % )		56.53
Proposed Coverage Area ( 60.30 % )		48.70
Total Prop. Coverage Area ( 60.3 % )		48.70
Balance coverage area ( 9.70 % )		7.83
FAR CHECK		
Perm. FAR Area ( 1.50 )		121.14
Total Perm. FAR area		121.14
Residential FAR		48.70
Proposed FAR Area		48.70
Total Proposed FAR Area		48.70
Consumed FAR (Factor)		0.60
Balance FAR Area		72.44
BUILT UP AREA CHECK		
Total Proposed BuiltUp Area		48.70
ARCHITECT (Regd)	LAW CHATURVEDI	
ENGINEER (Regd)		
SUPERVISOR (Regd)		
OWNER (Regd)	PRITI DEVI	
DEVELOPMENT AUTHORITY		LOCAL BODY

Building USE/SUBUSE Details

Building Name	Building Use	Building SubUse	Building Structure
A (SMT PRITI DEVI)	Residential	Bungalow/ Dwelling / Non Apartment	Non-Highrise

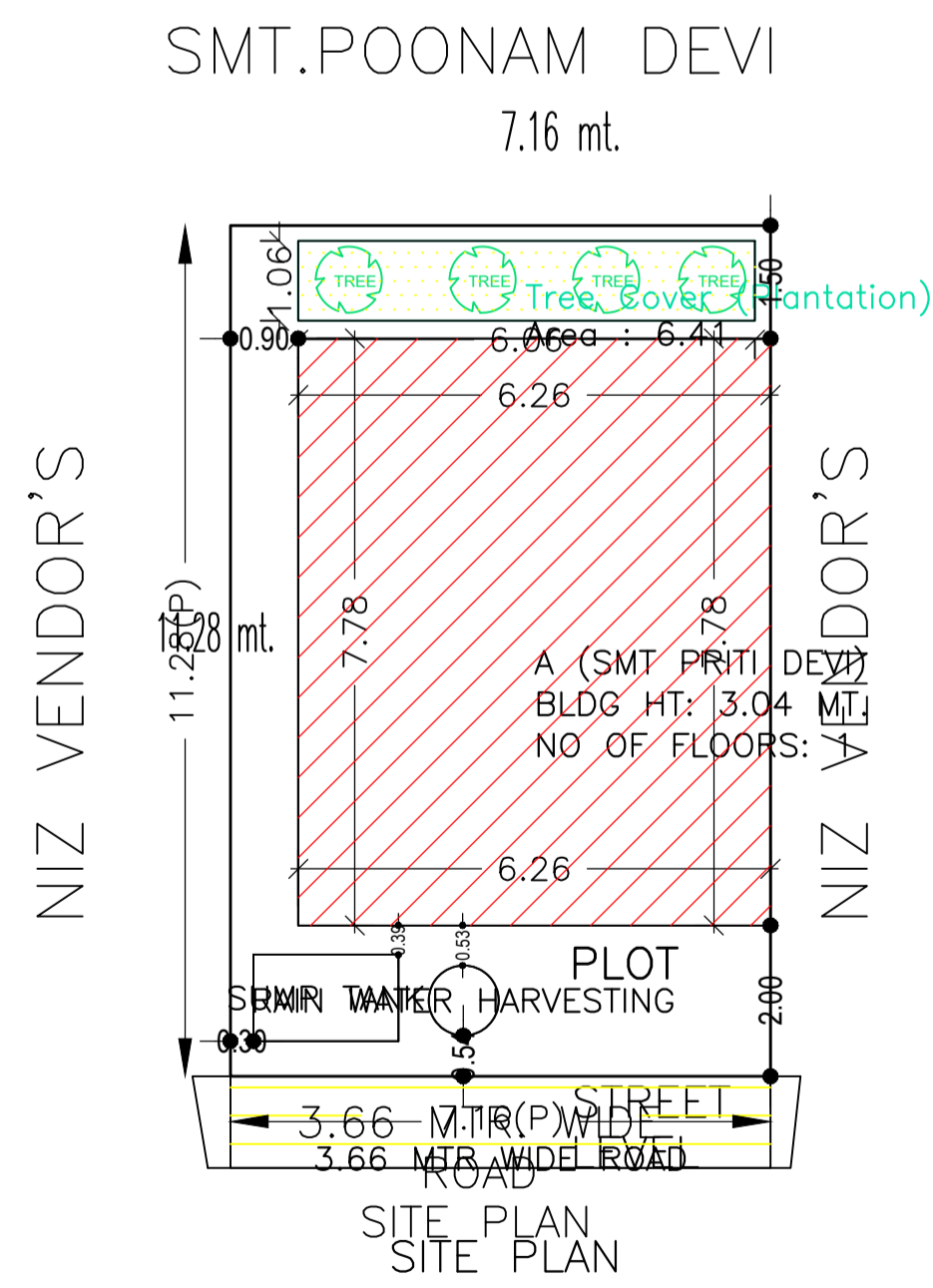

SITE PLAN (SCALE 1:100)

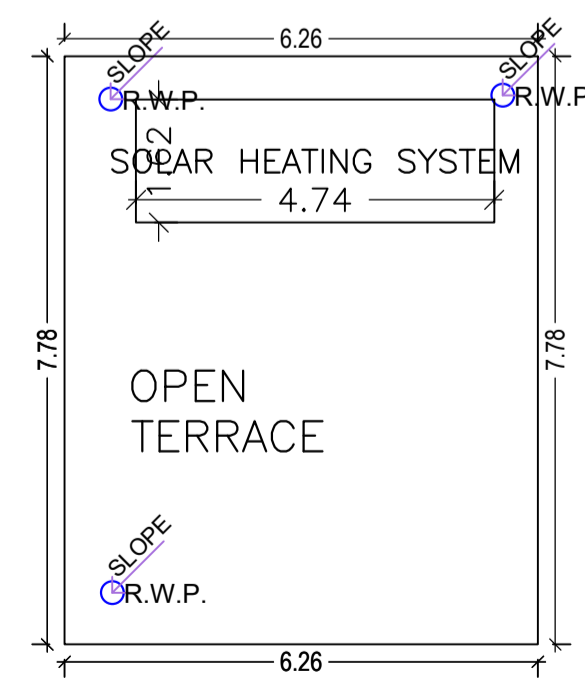

TERRACE FLOOR PLAN (SCALE 1:100)

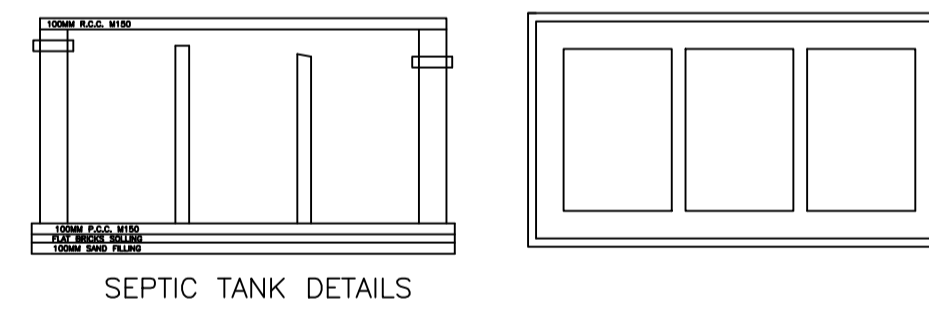

SEPTIC TANK DETAILS

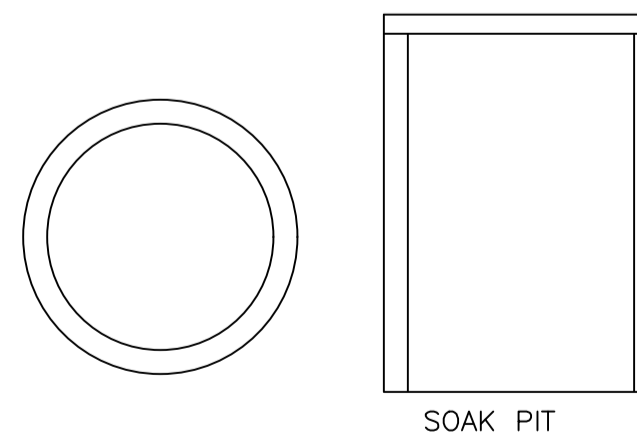

SOAK PIT

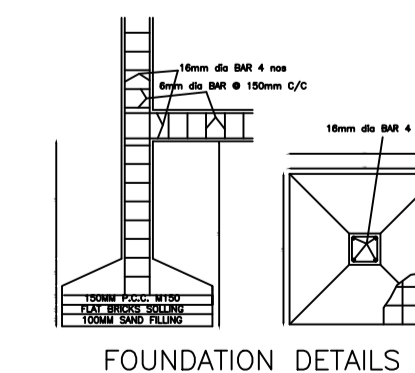

FOUNDATION DETAILS