

FRONT ELEVATION

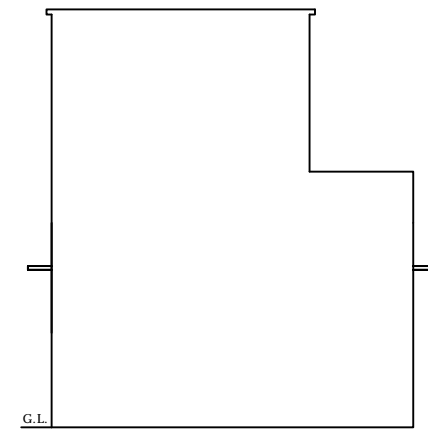

SOUTH SIDE ELEVATION

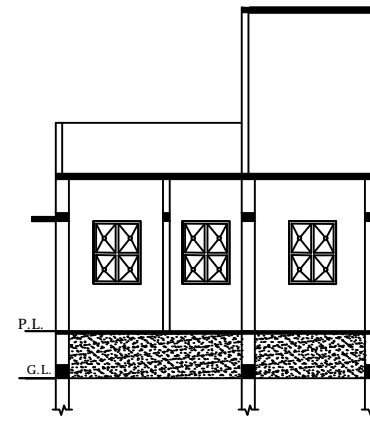

SECTION-YY

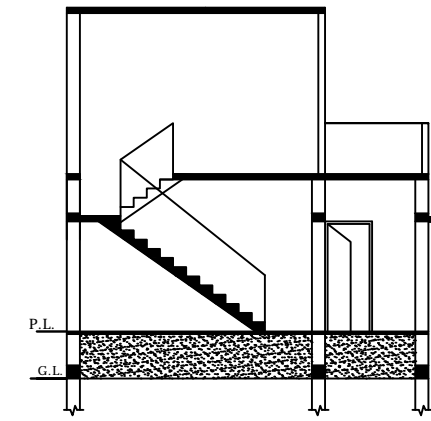

SECTION-XX

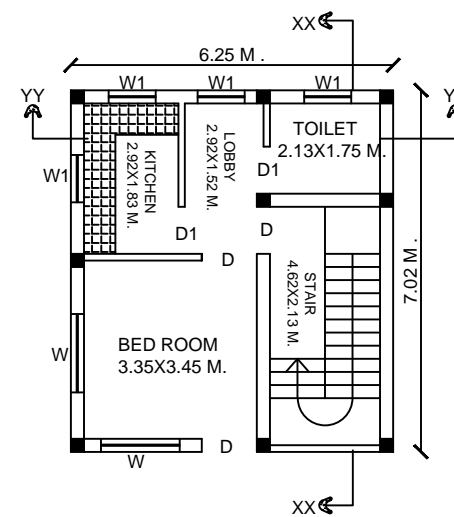

PROPOSED GROUND FLOOR PLAN

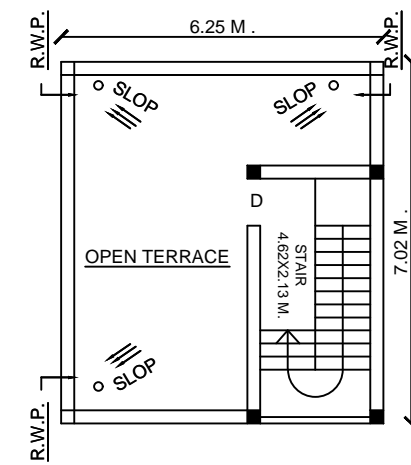

TERRACE FLOOR PLAN

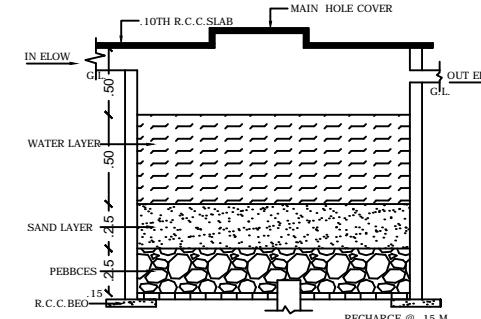

DETAIL OF RAIN WATER HARVESTING AND RECHARGE PIT (N.T.S.)

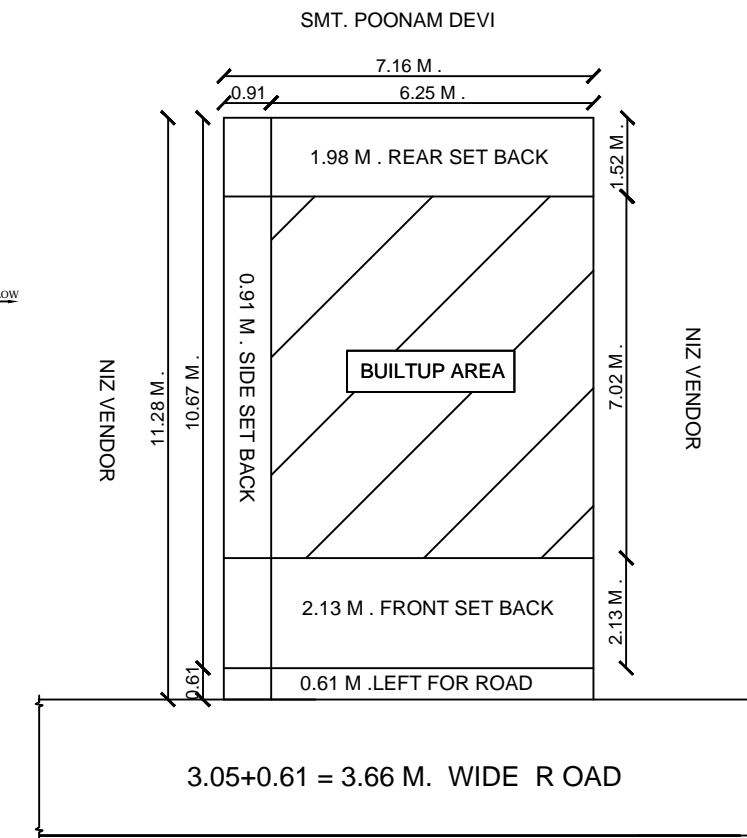

SITE PLAN

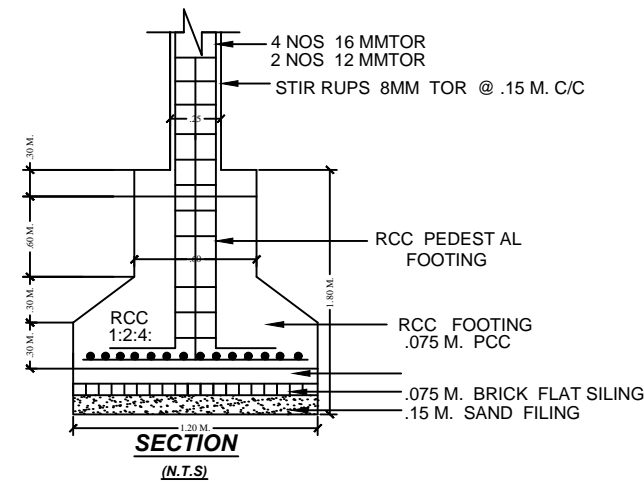

SECTION (N.T.S.)

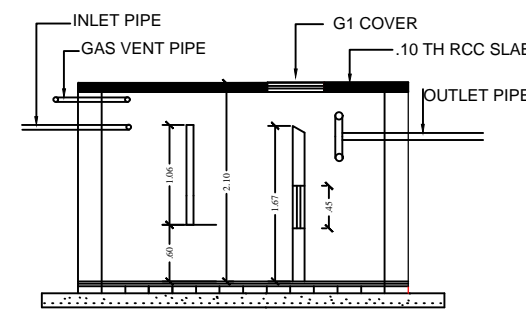

SECTION

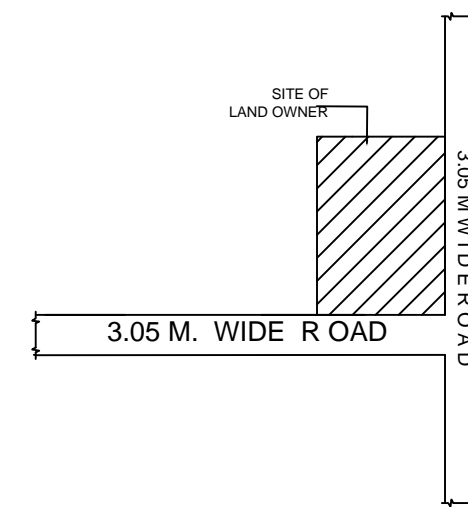
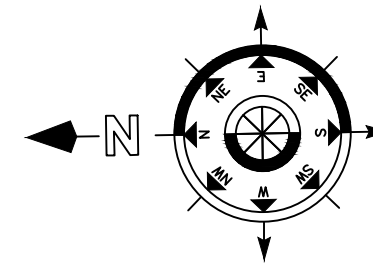

LOCATION PLAN

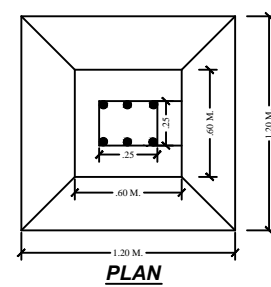

PLAN

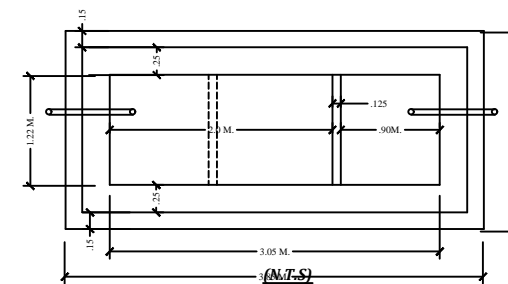

PLAN
DETAIL OF SEPTIC TANK

SCHEDULE OF DS & WS

TYPE	SIZE	REMARKS
D	1.06 M.X2.10 M.	F PANELED
D1	0.06 M.X2.10 M.	F PANELED
D2	0.75 M.X2.10 M.	F PANELED
W	1.50 M.X1.20 M.	F GLAZZED
W1	1.20 M.X1.20 M.	F GLAZZED
W2	0.91 M.X1.20 M.	F GLAZZED
C.GATE	2.10 M.X2.10 M.	IRON

SPECIFICATION

- 1 DETAIL OF R.C.C. FOOTING COLUMN FON (M.25)
- 2 1ST CLASS BRICK WORK IN CEMENT PLASTER (1:6)
- 3 1.25X.15TH. R.C.C. LINTEL BAND OVER DOOR'S & WINDOW'S
- 4 10TH. LIME CON. TERR.OVER .10TH. R.C.C. ROOF SLAB(M.25)
- 5 SAL WOOD FRAME & SUAM WOOD SHUTTER.
- 6 0.012TH. IN CEMENT PLASTER IN BOTH SIDE WACC (1:6)
- 7 MARBLE OR MOSAIC FLOORING OVER .110TH. DRY RAMMED KHOA OVER B.F. SOILING , OVER LOCAL SAND FILLING .
- 8 2 CUAT OF WHITE & COLOUR WASH AS PER CHOICE.
- 9 17CM.WIDE & 30 CM. PUCCA DRAIN AROUND THE BUILDING .

TOTAL PLOT AREA	=	80.76	SQM.
NET PLOT AREA	=	76.40	SQM.
TOTAL OPEN LAND AREA	=	32.53	SQM.
GROUND FLOOR BUILT UP AREA	=	43.87	SQM.
TOTAL	=	43.87	SQM.
F.A.R.	=	0.57	
% OF COVRED AREA	=	58 %	
BUILDING HEIGHT	=	3.96 M.	

PROPOSED RESIDENTIAL BUILDING OF

NAME- SMT. PRITI DEVI
 W/O. - SRI SANTOSH SONY
 MOUZA - NAGWAN
 P.S. - CHATRA
 P.S. NO.- 175
 WARD NO. - 03
 KHATA NO.- 244
 H. NO.-
 PLOT NO.- 131
 TOUZI NO.- 28
 DIST. - CHATRA (JHARKHAND)

SIGNATURE OF APPLICANT

MAP APPROVED BY

SIGNATURE OF ENGINEER