

FAR & Tenement Details (Table 4c-1)

Building	No. of Same Bldg	Total Built Up Area (Sq.mt.)	Proposed FAR Area (Sq.mt.) Resi.	Total FAR Area (Sq.mt.)	Total Consumed Additional FAR Area (Sq.mt.)	Tnmt (No.)
A (SMT PRIYANKA KUMARI)	1	141.89	141.89	141.89	141.89	01
Grand Total :	1	141.89	141.89	141.89	141.89	01

Proposal Basic Information

Proposal File No.	CHNP/BP/0013/W22/2021
Owner Name	SMT PRIYANKA KUMARI
Khata No	147
Plot No	941
Village Name	Nagma
Use	Residential
SubUse	Bungalow/ Dwelling / Non Apartment

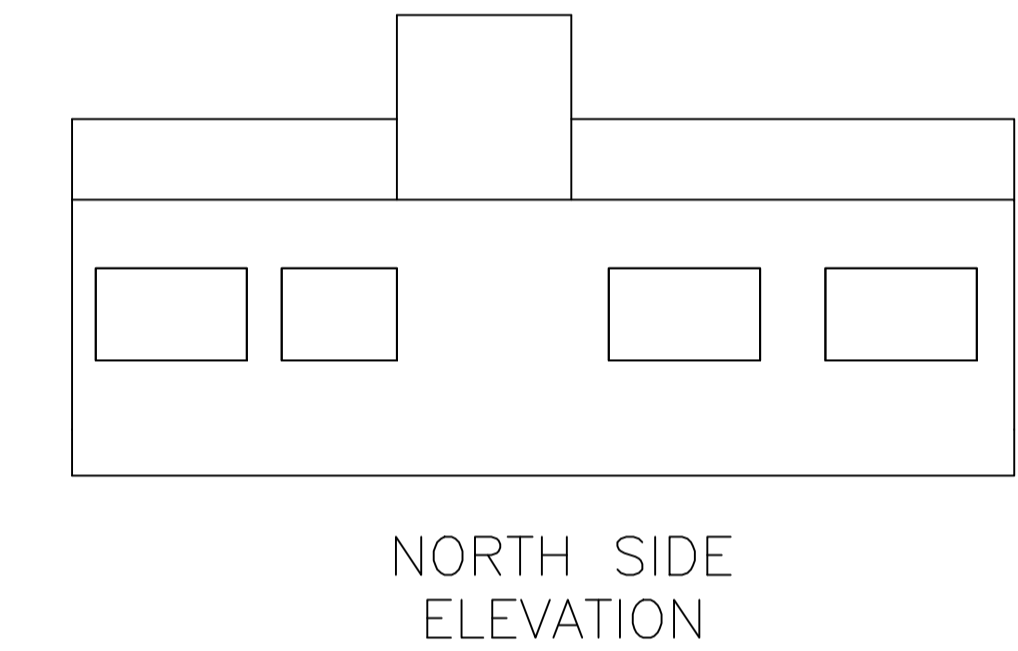
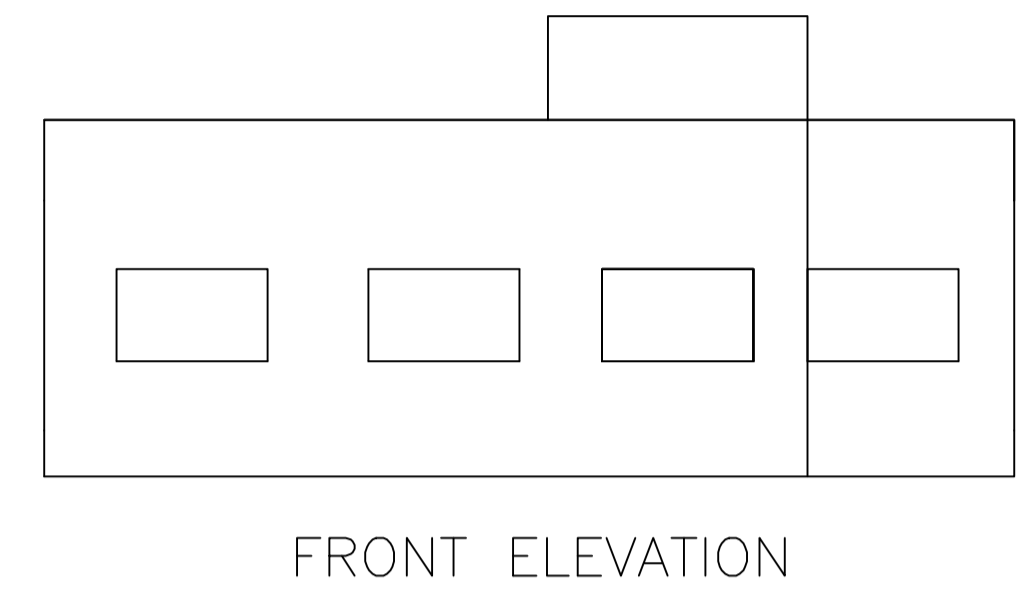

AREA STATEMENT CHATRA NAGAR PRISHAD

VERSION NO: 1.0.57
VERSION DATE: 16/10/2020

PROJECT DETAIL:

Region: JHARKHAND URBAN LOCAL BODIES	Plot Use: Residential
District: CHATRA	Plot SubUse: Bungalow/ Dwelling / Non Apartment
Authority: CHATRA NAGAR PRISHAD	PlotNearbyReligiousStructure: NA
Inward No: CHNP/BP/0013/W22/2021	Plot/SubPlot No: 941
Application Type: General Proposal	North: Survey No. - VENDOR'S LAND
Project Type: Building Permission	South: Survey No. - MD ISLAM
Nature of Development: New	East: Road Width - 3.66
Location of Development Area: Old Area	West: Survey No. - LAND OF RAJ KUMAR SAH

AREA DETAILS:

AREA OF PLOT (Minimum)	(A)	SQ.MT.
NET AREA OF PLOT(Gross Plot Area - Deduction from Gross Plot area)	(A-Deductions)	243.15
Deduction for Balance Plot Area(from Gross Plot Area)		
Common Plot		14.41
Total		14.41
BALANCE AREA OF PLOT(Net Plot Area - Recreational/Amenity space)	(A-Deductions)	228.74
PLOT AREA FOR COVERAGE(Net Plot Area)	(A-Deductions)	243.15
Plot Area for FAR (Net Plot Area + Road/Widening Area)	(A-Deductions)	243.15

COVERAGE CHECK

Permissible Coverage area (60.00 %)	145.89
Proposed Coverage Area (58.35 %)	141.89
Total Prop. Coverage Area (58.35 %)	141.89
Balance coverage area (1.65 %)	4.00

FAR CHECK

Perm. FAR Area (1.50)	364.72
Total Perm. FAR area	364.72
Residential FAR	141.89
Proposed FAR Area	141.89
Total Proposed FAR Area	141.89
Consumed FAR (Factor)	0.58
Balance FAR Area	222.83

BUILT UP AREA CHECK

Total Proposed BuiltUp Area	141.89
-----------------------------	--------

ARCHITECT (Regd) ABDUL KALAM
ENGINEER (Regd)
SUPERVISOR (Regd)
OWNER (Regd) SMT PRIYANKA KUMARI
DEVELOPMENT AUTHORITY LOCAL BODY

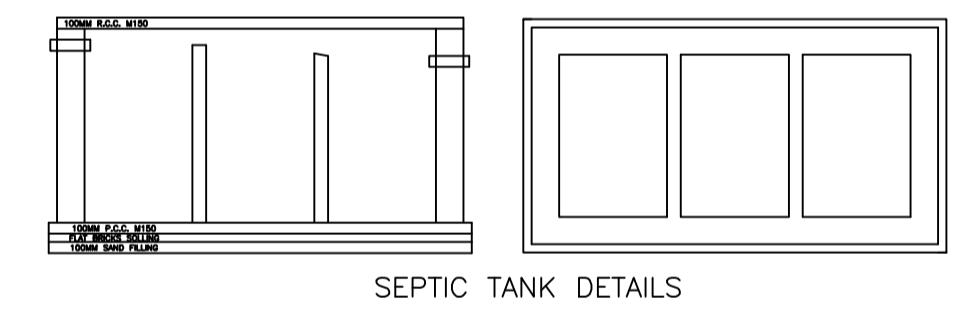
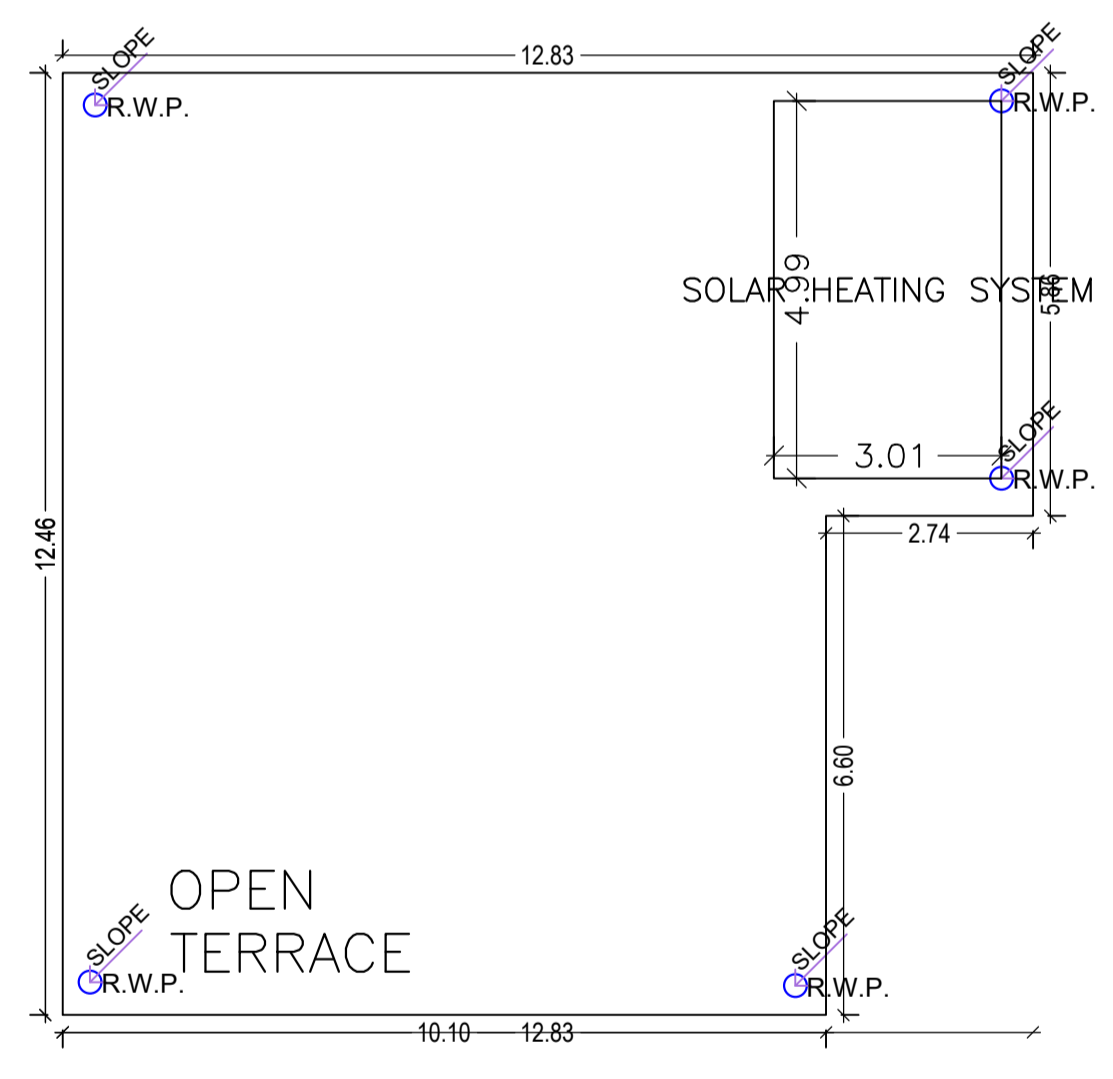
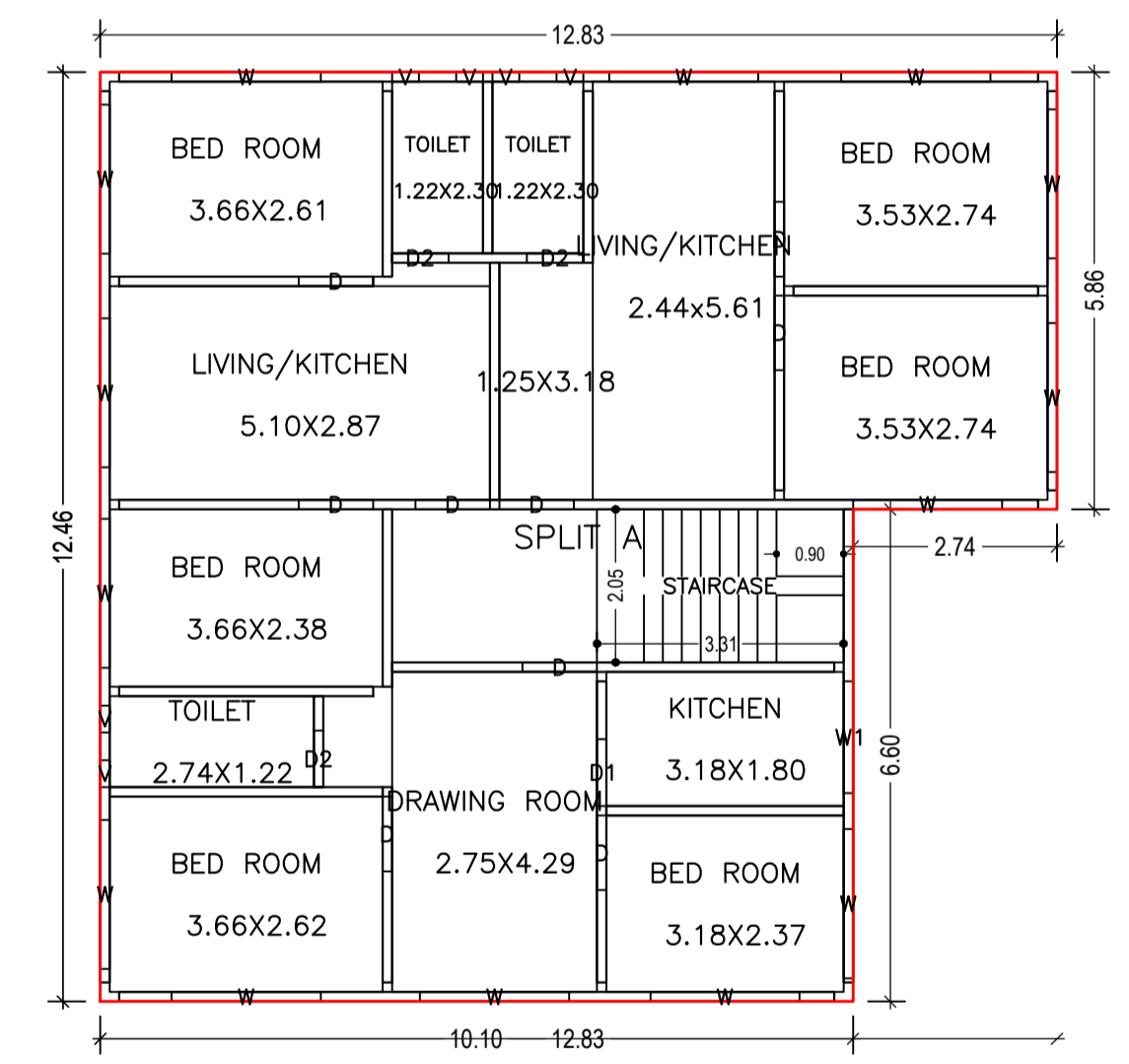

COLOR INDEX

PLOT BOUNDARY	Black
ABUTTING ROAD	Green
PROPOSED CONSTRUCTION	Red
COMMON PLOT	Yellow
ROAD WIDENING AREA	White
EXISTING (To be retained)	Blue
EXISTING (To be demolished)	Orange

Buildingwise Floor FAR Details

Floor Name	Building Name A (SMT PRIYANKA KUMARI)		Total	
	Proposed Built Up Area (Sq.mt.)	Proposed FAR Area (Sq.mt.)	Total Proposed Built Up Area (Sq.mt.)	Total FAR Area (Sq.mt.)
Ground Floor	141.89	141.89	141.89	141.89
Terrace Floor	0.00	0.00	0.00	0.00
Total :	141.89	141.89	141.89	141.89

Building :A (SMT PRIYANKA KUMARI)

Floor Name	Total Built Up Area (Sq.mt.)	Proposed FAR Area (Sq.mt.) Resi.	Total FAR Area (Sq.mt.)	Total Consumed Additional FAR Area (Sq.mt.)	Tnmt (No.)
Ground Floor	141.89	141.89	141.89	141.89	01
Terrace Floor	0.00	0.00	0.00	0.00	00
Total :	141.89	141.89	141.89	141.89	01
Total Number of Same Buildings	1				
Total :	141.89	141.89	141.89	141.89	01

SCHEDULE OF DOOR:

BUILDING NAME	NAME	LENGTH	HEIGHT	NOS
A (SMT PRIYANKA KUMARI)	D2	0.76	2.13	03
A (SMT PRIYANKA KUMARI)	D1	0.90	2.13	01
A (SMT PRIYANKA KUMARI)	D	1.00	2.13	09

SCHEDULE OF WINDOW/VENTILATION:

BUILDING NAME	NAME	LENGTH	HEIGHT	NOS
A (SMT PRIYANKA KUMARI)	V	0.36	1.00	06
A (SMT PRIYANKA KUMARI)	W1	1.50	1.22	01
A (SMT PRIYANKA KUMARI)	W	2.00	1.22	14

UnitBUA Table for Building :A (SMT PRIYANKA KUMARI)

FLOOR	Name	UnitBUA Type	UnitBUA Area	Carpet Area	No. of Rooms	No. of Tenement
GROUND FLOOR PLAN	SPLIT A	FLAT	141.89	128.02	13	1
Total:	-	-	141.89	128.02	13	1

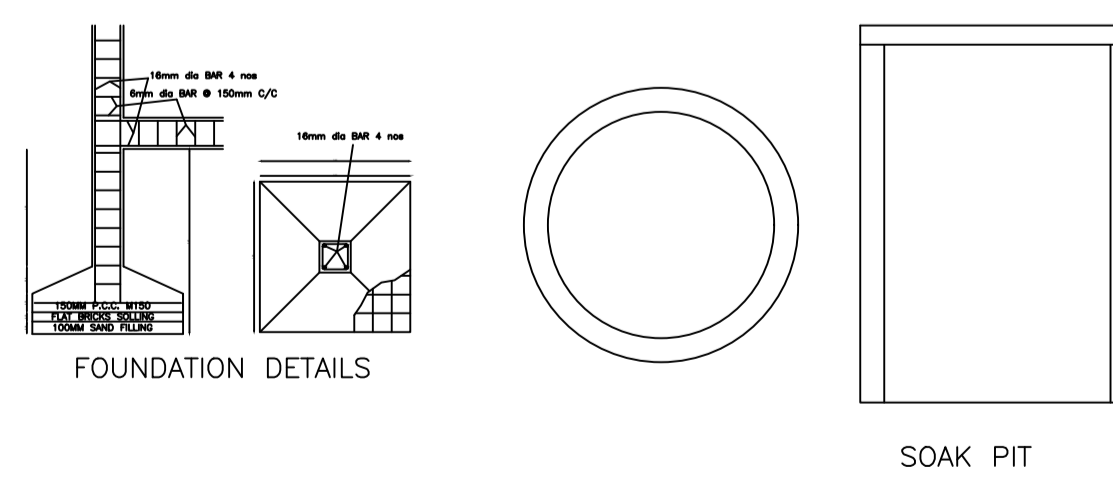

LTP NAME AND SIGNATURE	STRUCTURAL ENG'S NAME AND SIGNATURE	BUILDER NAME AND SIGNATURE	DIGITAL SIGNATURE
ABDUL KALAM CHNP/ENG/0016/2019			