

SITE PLAN

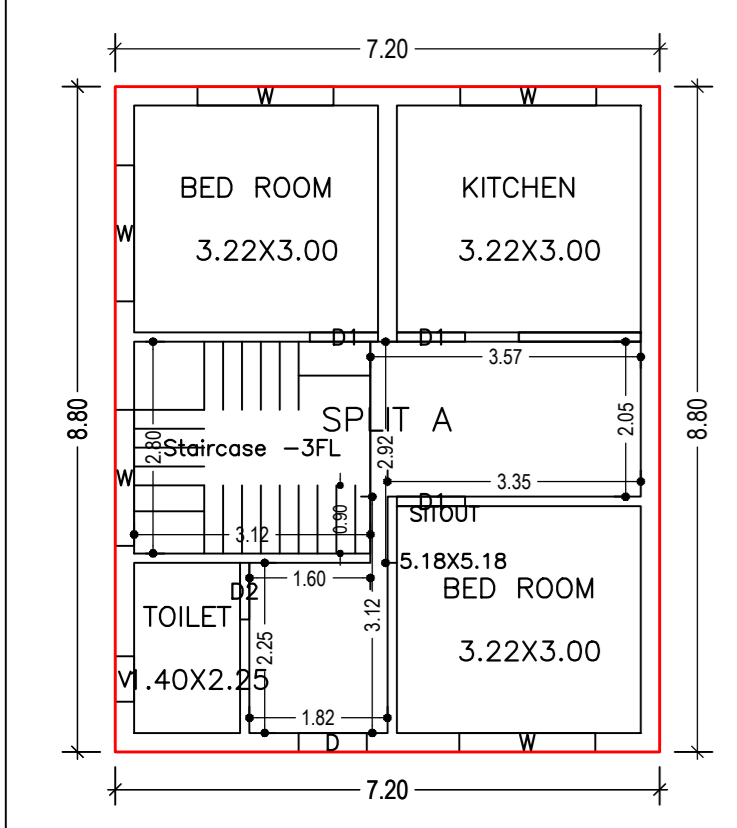

GROUND FLOOR PLAN (Proposed) (SCALE 1:100)

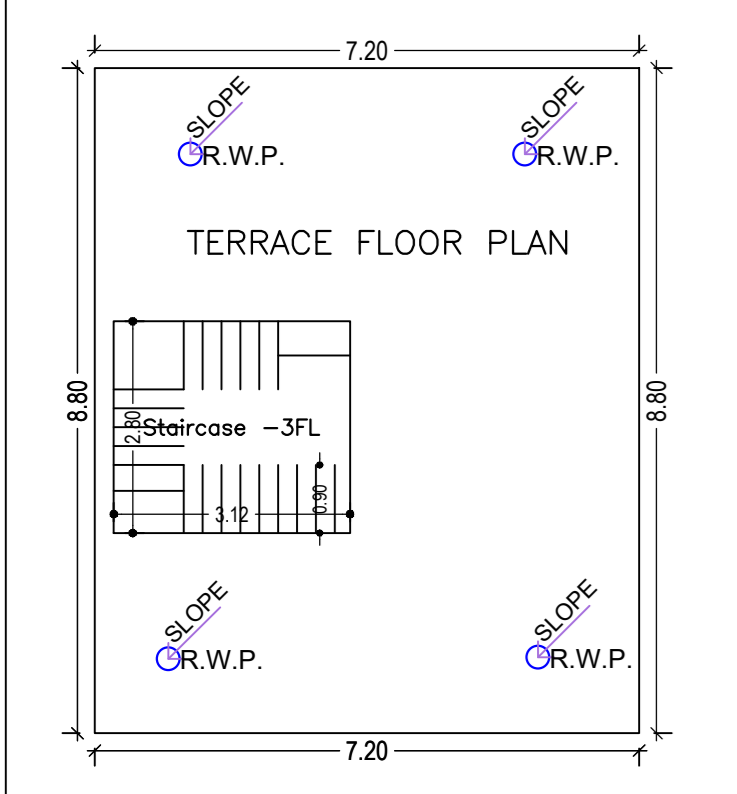

TERRACE FLOOR PLAN (SCALE 1:100)

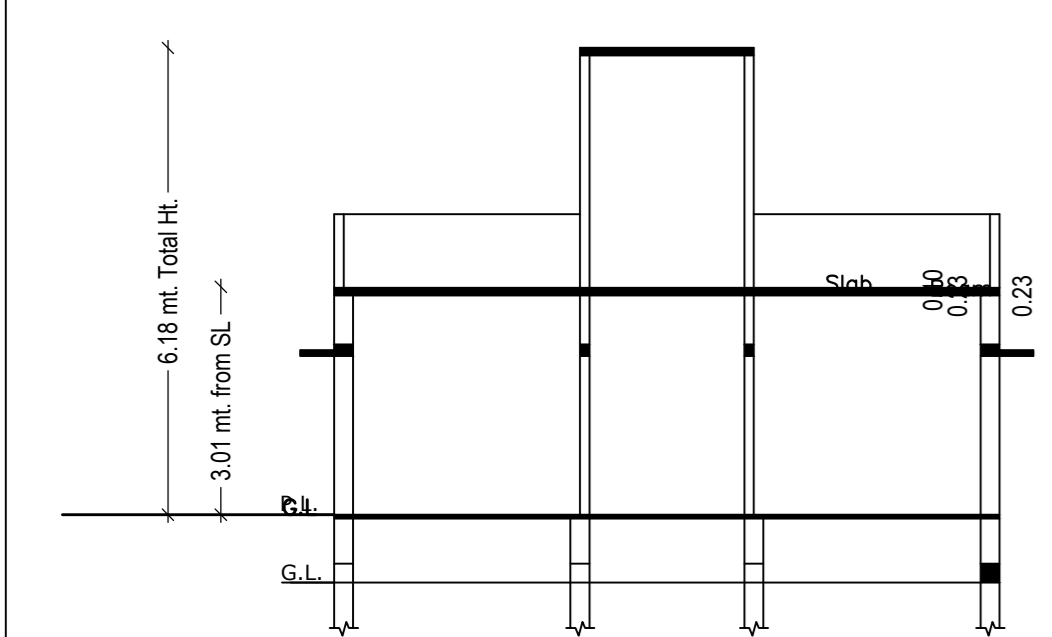

SECTION-YY

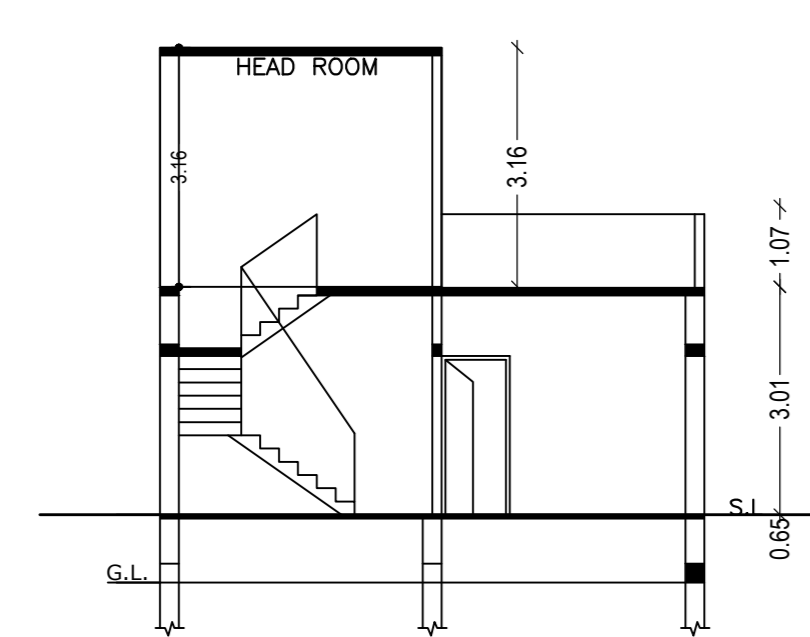

SECTION-YY

Building :A (SMT GURIA KUMARI)

Floor Name	Total Built Up Area (Sq.mt)	Proposed FAR Area (Sq.mt)	Total FAR Area (Sq.mt)	Total Consumed Additional FAR Area (Sq.mt)	Trmt (No.)
Ground Floor	63.36	63.36	63.36	63.36	01
Terrace Floor	0.00	0.00	0.00	0.00	00
<b>Total</b>	<b>63.36</b>	<b>63.36</b>	<b>63.36</b>	<b>63.36</b>	<b>01</b>

SCHEDULE OF DOOR:

BUILDING NAME	NAME	LENGTH	HEIGHT	NOS
A (SMT GURIA KUMARI)	D2	0.75	2.13	01
A (SMT GURIA KUMARI)	D1	0.90	2.13	03
A (SMT GURIA KUMARI)	D	0.90	2.13	01

SCHEDULE OF WINDOW/VENTILATION:

BUILDING NAME	NAME	LENGTH	HEIGHT	NOS
A (SMT GURIA KUMARI)	V	0.60	2.70	01
A (SMT GURIA KUMARI)	W	1.80	2.70	05

Unit/BUA Table for Building :A (SMT GURIA KUMARI)

FLOOR	Name	Unit/BUA Type	Unit/BUA Area	Carpet Area	No. of Rooms	No. of Tenement
GROUND FLOOR PLAN	SPLIT A	FLAT	46.08	45.88	5	1
Total	-	-	46.08	45.88	5	1

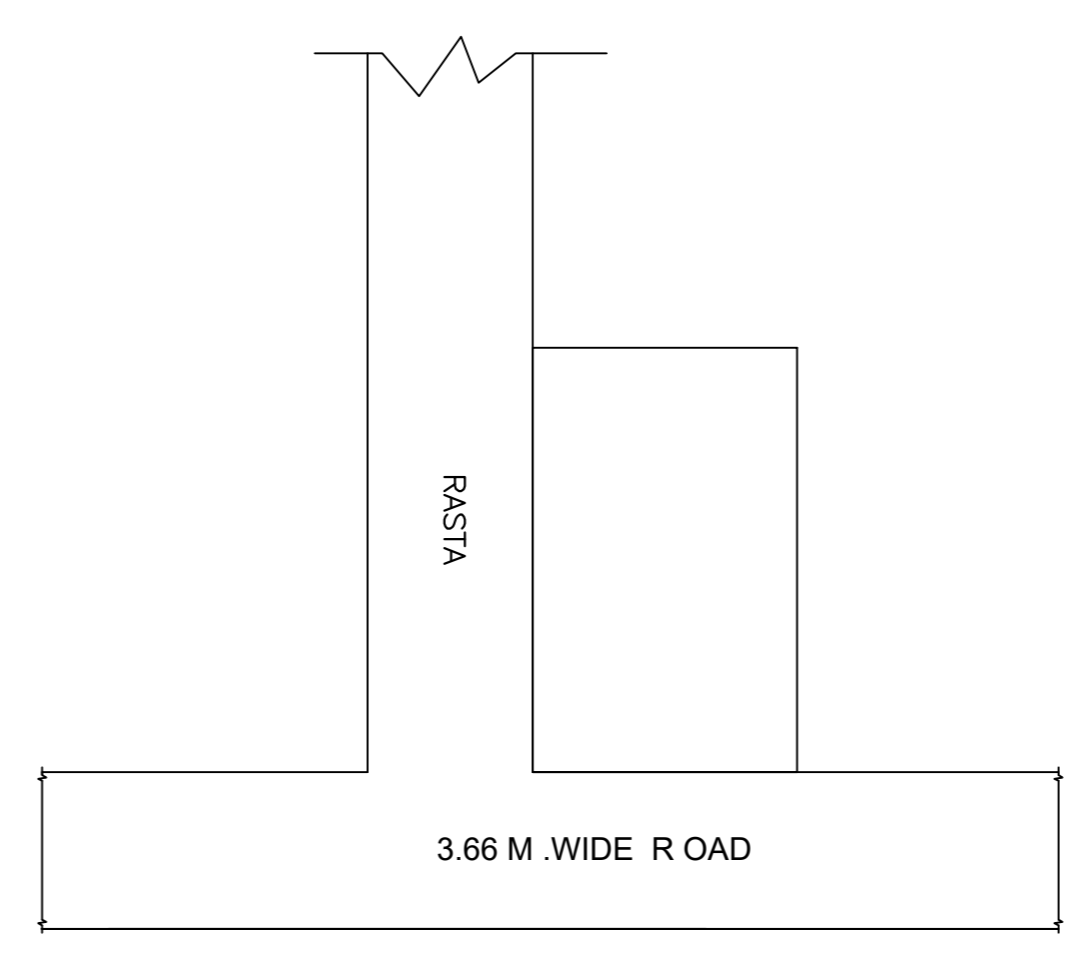

LOCATION PLAN

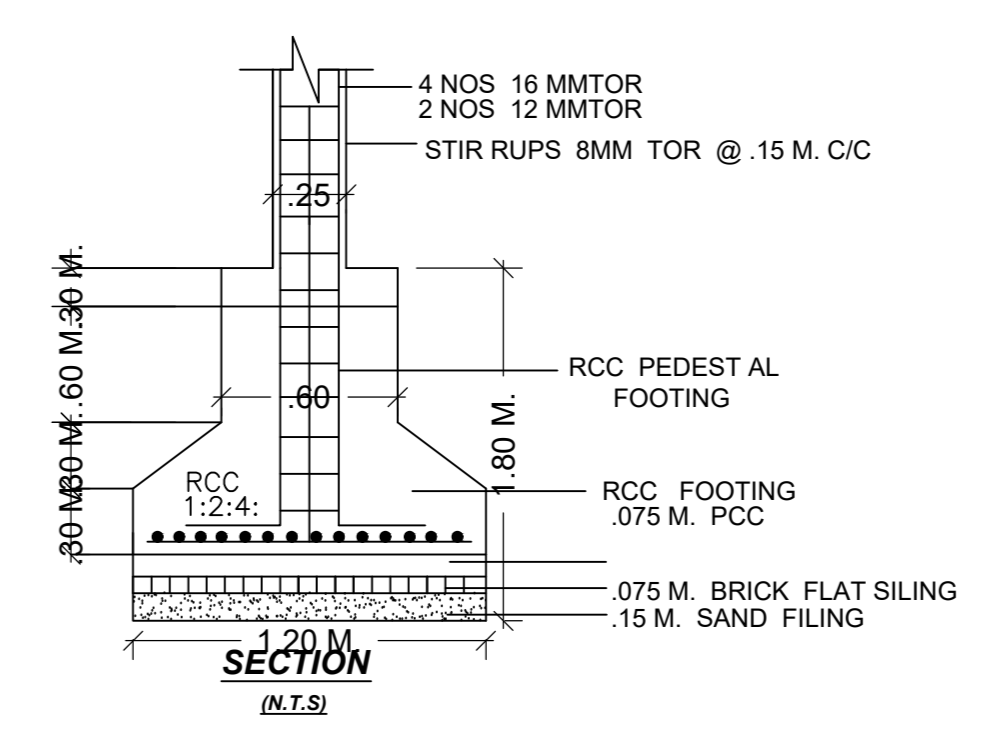

SECTION (N.E.S.)

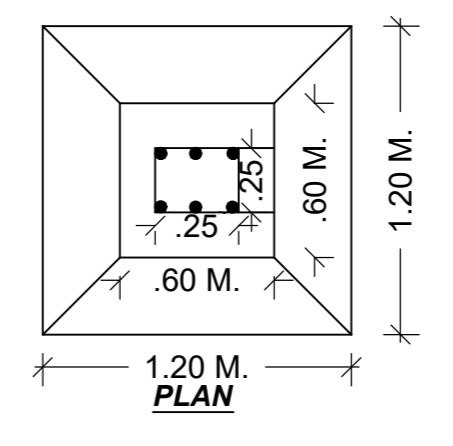

PLAN

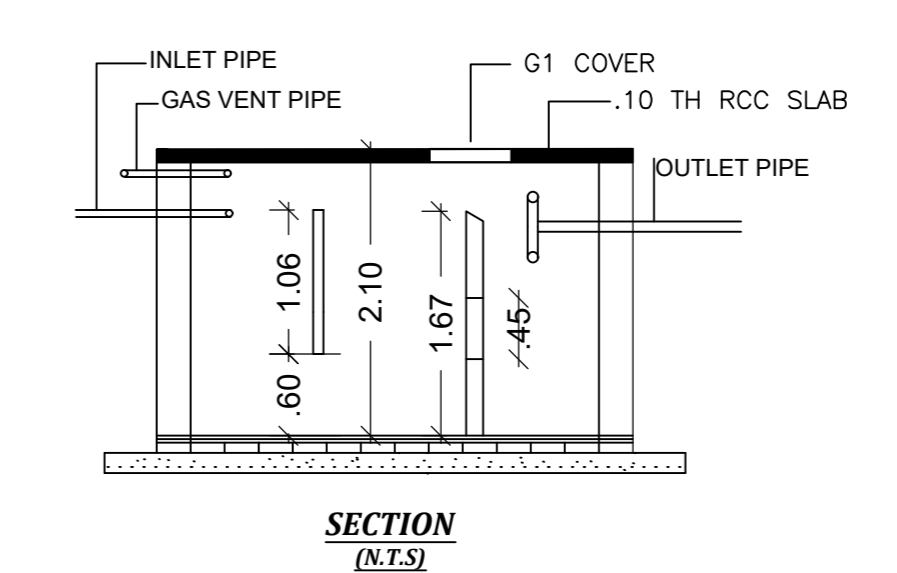

SECTION (N.E.S.)

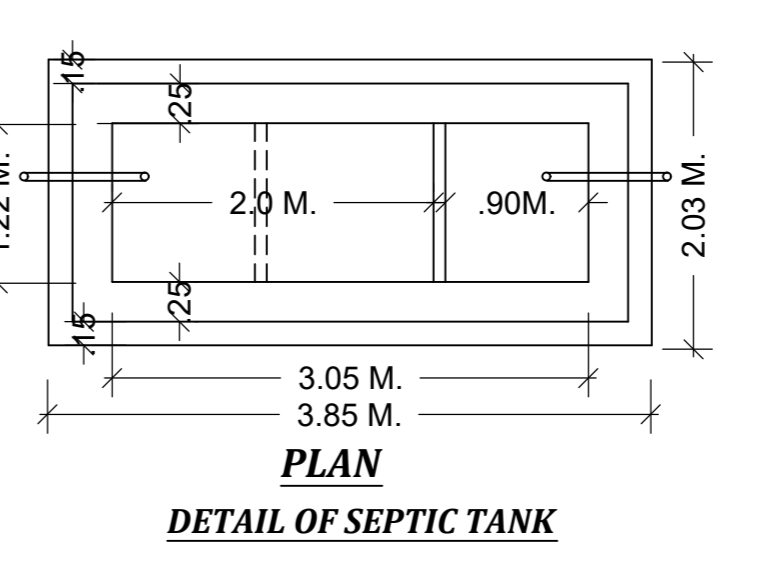

PLAN  
DETAIL OF SEPTIC TANK

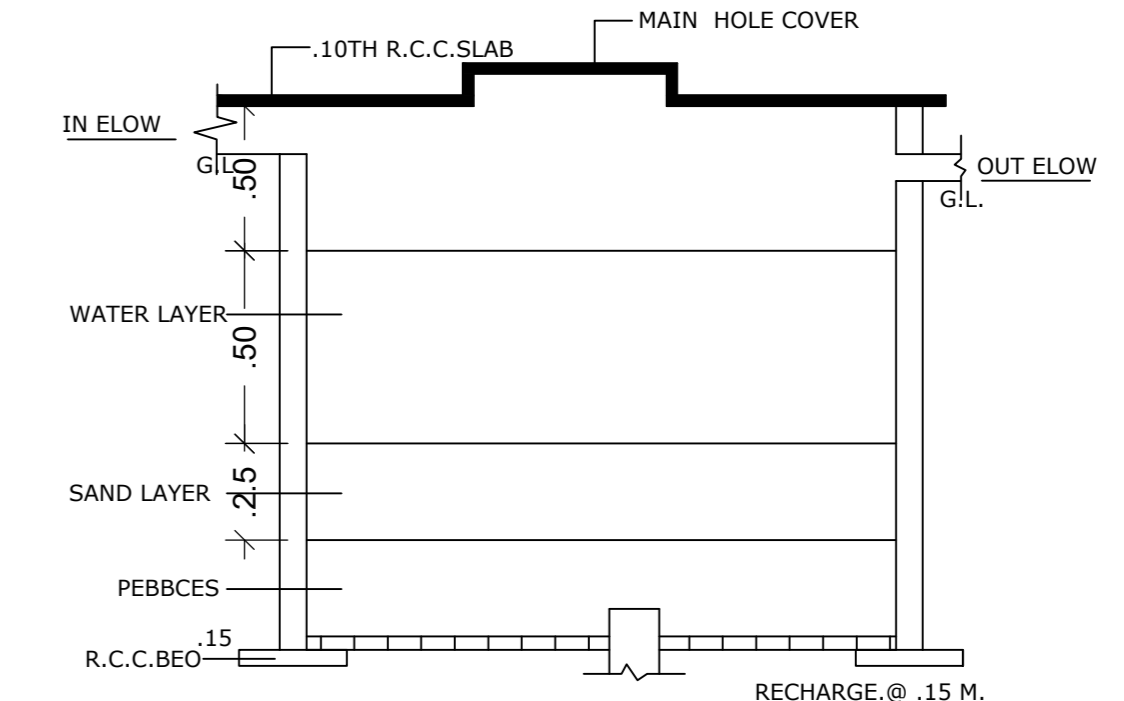

DETAIL OF RAIN WATER HARVESTING AND RECHARGE PIT (N.T.S.)

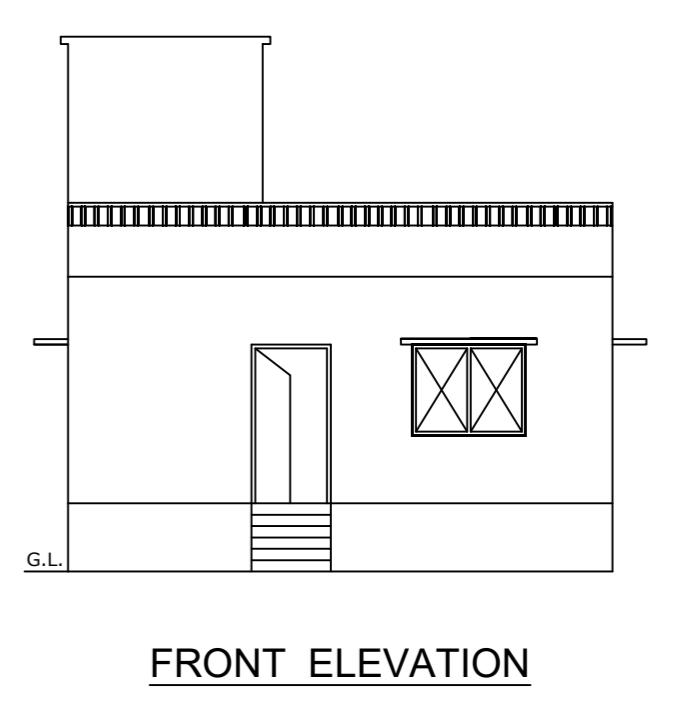

FRONT ELEVATION

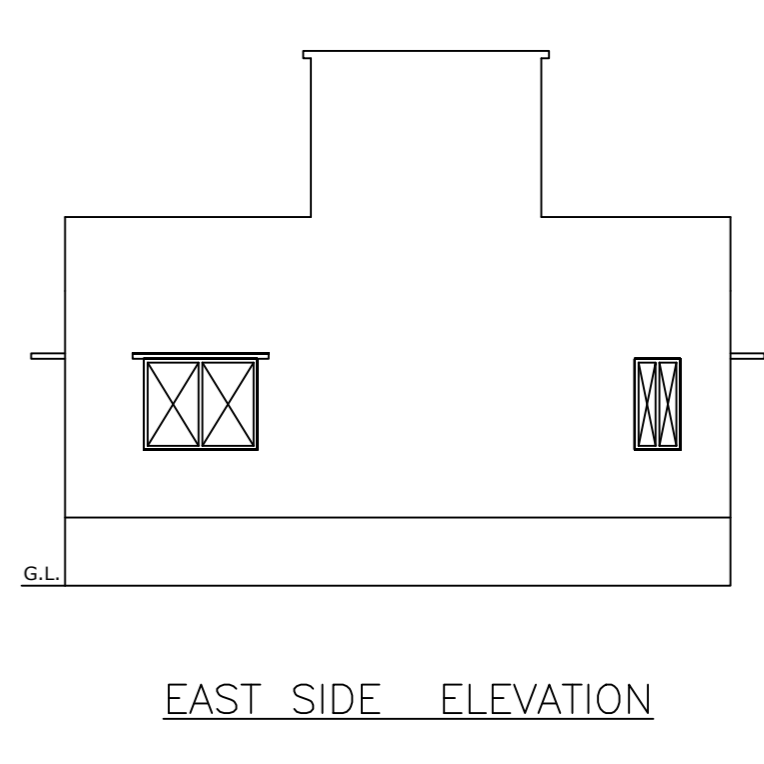

EAST SIDE ELEVATION

Proposal Basic Information

Proposal File No.	CHNP/0012/W03/2021
Owner Name	GUDYA KUMARI
Khata No.	244
Plot No.	125
Village Name	Chatra
Use	Residential
SubUse	Bungalow Dwelling / Non Apartment

AREA STATEMENT CHATRA NAGAR PRISHAD

VERSION NO. 1.0.55  
VERSION DATE: 16/10/2020

PROJECT DETAIL:	Region:	JHARKHAND URBAN	Plot Use:	Residential
LOCAL BODIES	District:	CHATRA	Plot SubUse:	Bungalow Dwelling / Non Apartment
Authority:	CHATRA NAGAR PRISHAD	Plot Nearest/Religious/Structure:	NA	
Inward No.	CHNP/0012/W03/2021	Plot/SubPlot No.:	125	
Application Type:	General Proposal	North Road Width - ROAD		
Project Type:	Building Permission	South Plot No. - PLOT NO.-125		
Nature of Development:	New	East Road Width - ROAD		
Location of Development Area:	Old	West Plot No. - 125		

AREA DETAILS:	Area	SQ.MT.
AREA OF PLOT (Minimum)	(A)	101.48
NET AREA OF PLOT (Gross Plot Area - Deduction from Green Plot Area)	(A-Deductions)	101.48
Deduction for Balance Plot Area/From Gross Plot Area		
Common Plot		12.91
Total		12.91
BALANCE AREA OF PLOT (Net Plot Area - Non-Residential/Amenity space)	(A-Deductions)	88.57
FLOOR AREA FOR COVERAGE (Net Plot Area)	(A-Deductions)	101.48
Plot Area for FAR (Net Plot Area + Road/Widening Area)	(A-Deductions)	101.48

COVERAGE CHECK

Permissible Coverage area (70.00 %)	71.03
Proposed Coverage Area (62.44 %)	63.36
Total Prop. Coverage Area (62.44 %)	63.36
Balance coverage area (7.56 %)	7.67

FAR CHECK

Form FAR Area (1.50)	152.21
Total Perm. FAR area	152.21
Residential FAR	63.36
Proposed FAR Area	63.36
Total Proposed FAR Area	63.36
Consumed FAR (Factor)	0.62
Balance FAR Area	88.85
BUILT UP AREA CHECK	
Total Proposed BuiltUp Area	63.36

ARCHITECT (Regd) LAW CHATURVEDI  
ENGINEER (Regd)  
SUPERVISOR (Regd)  
OWNER (Regd) GUDYA KUMARI  
DEVELOPMENT AUTHORITY LOCAL BODY

COLOR INDEX

PLOT BOUNDARY	Green
ADJUTING ROAD	Red
PROPOSED CONSTRUCTION	Yellow
COMMON PLOT	Blue
ROAD WIDENING AREA	Orange
EXISTING (To be retained)	Light Blue
EXISTING (To be demolished)	Dark Blue

Buildingwise Floor FAR Details

Floor Name	Building Name		Total	
	Proposed Built Up Area (Sq.mt)	Proposed FAR Area (Sq.mt)	Total Proposed Built Up Area (Sq.mt)	Total FAR Area (Sq.mt)
Ground Floor	63.36	63.36	63.36	63.36
Terrace Floor	0.00	0.00	0.00	0.00
<b>Total</b>	<b>63.36</b>	<b>63.36</b>	<b>63.36</b>	<b>63.36</b>

Building USE/SUBUSE Details

Building Name	Building Use	Building SubUse	Building Structure
A (SMT GURIA KUMARI)	Residential	Bungalow Dwelling / Non Apartment	Non-Highrise

FAR & Tenement Details (Table 4c-1)

Building	No. of Same Bldg	Total Built Up Area (Sq.mt)	Proposed FAR Area (Sq.mt)	Total FAR Area (Sq.mt)	Total Consumed Additional FAR Area (Sq.mt)	Trmt (No.)
A (SMT GURIA KUMARI)	1	63.36	63.36	63.36	63.36	01
<b>Grand Total</b>	<b>1</b>	<b>63.36</b>	<b>63.36</b>	<b>63.36</b>	<b>63.36</b>	<b>01</b>

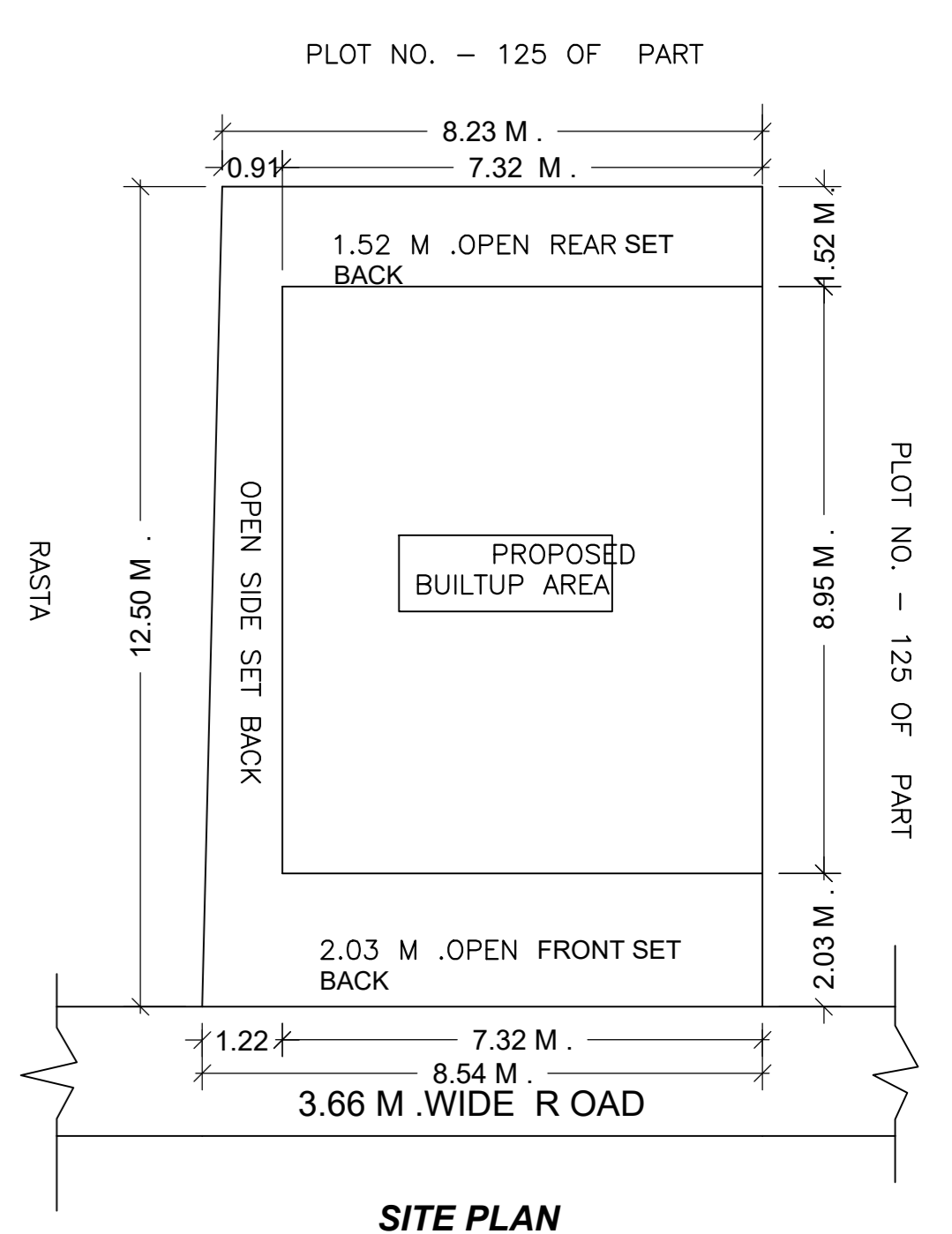

SITE PLAN

LTP NAME AND SIGNATURE LAW CHATURVEDI CHNP/ENG/004/2017	STRUCTURAL ENGS NAME AND SIGNATURE	BUILDER NAME AND SIGNATURE	DIGITAL SIGNATURE
---	------------------------------------	----------------------------	-------------------