

FRONT ELEVATION

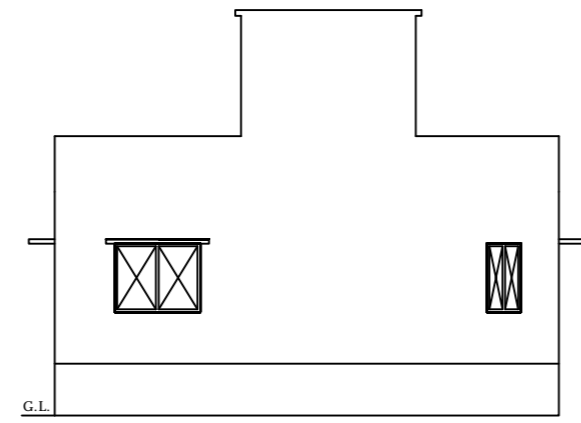

EAST SIDE ELEVATION

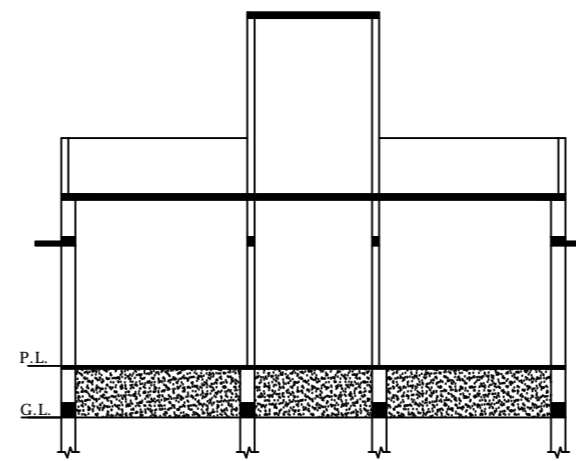

SECTION- YY

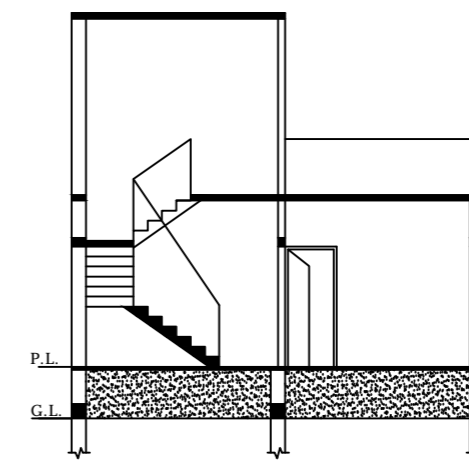

SECTION- YY

SCHEDULE OF DS & WS		
TYPE	SIZE	REMARKS
D	1.06 M.X2.10 M.	F PANELED
D1	0.06 M.X2.10 M.	F PANELED
D2	0.75 M.X2.10 M.	F PANELED
W	1.50 M.X1.20 M.	F GLAZZED
W1	1.20 M.X1.20 M.	F GLAZZED
W2	0.91 M.X1.20 M.	F GLAZZED
C.GATE	2.10 M.X2.10 M.	IRON

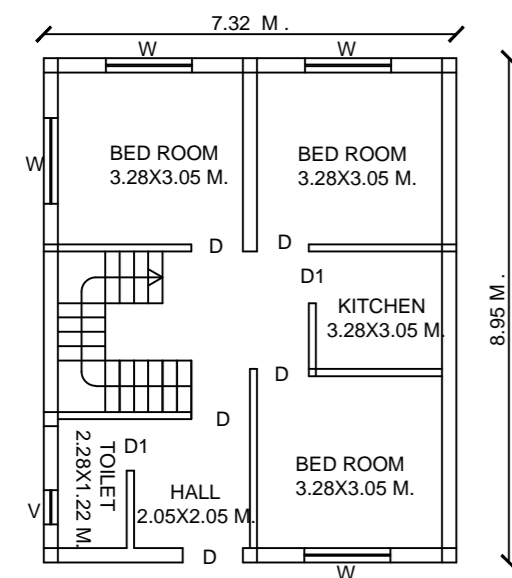

PROPOSED GROUND FLOOR PLAN

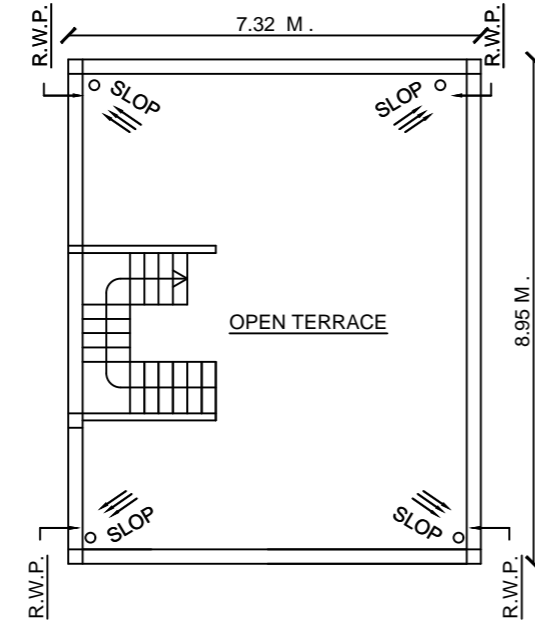

TERRACE FLOOR PLAN

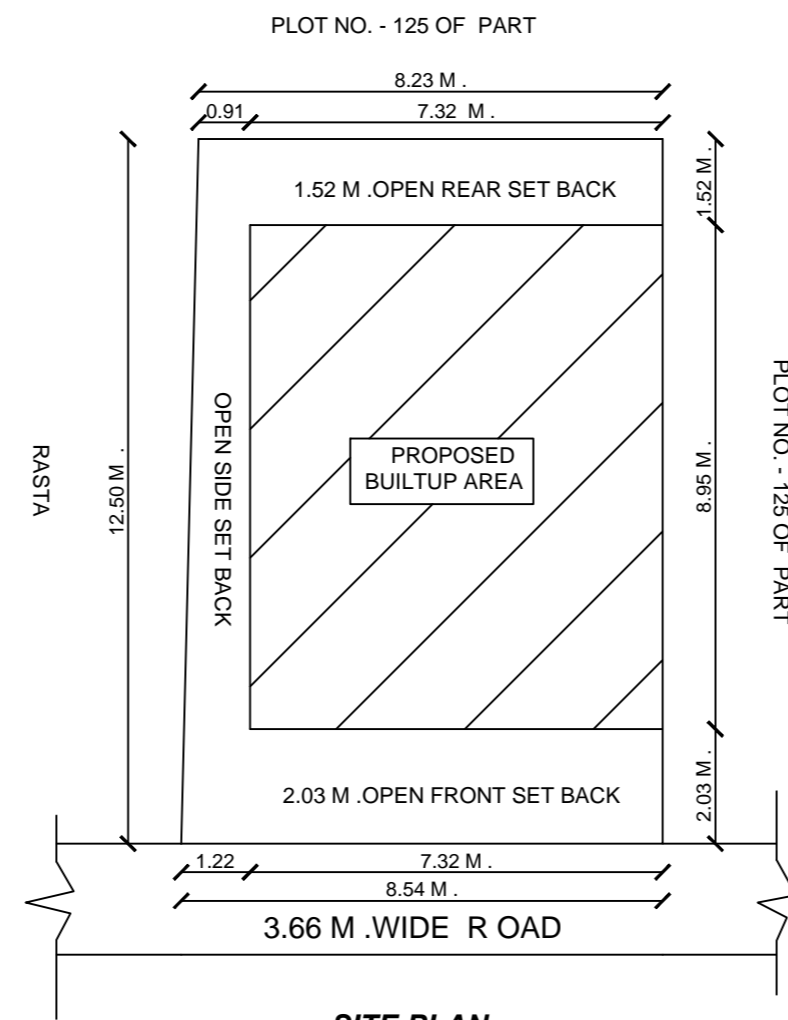

SITE PLAN

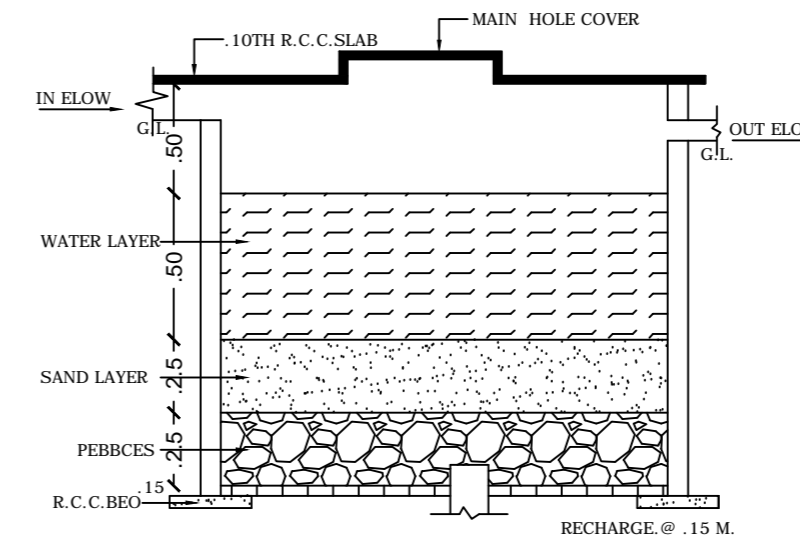

DETAIL OF RAIN WATER HARVESTING AND RECHARGE PIT. (N.T.S.)

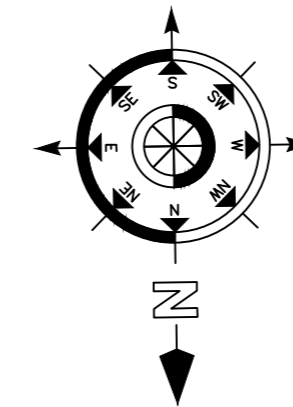

SPECIFICATION		
1	DETAIL OF R.C.C. FOOTING COLUMN FON ( M.25 )	
2	1ST CLASS BRICK WORK IN CEMENT PLASTER ( 1:6 )	
3	1.25X.15TH. R.C.C. LINTEL BAND OVER DOOR'S & WINDOW'S	
4	10TH. LIME CON. TERR.OVER .10TH. R.C.C. ROOF SLAB(M.25)	
5	SAL WOOD FRAME & SUAM WOOD SHUTTER.	
6	0.012TH. IN CEMENT PLASTER IN BOTH SIDE WACC ( 1:6 )	
7	MARBLE OR MOSAIC FLOORING OVER .110TH. DRY RAPPED KHOA OVER B.F. SOILING , OVER LOCAL SAND FILLING .	
8	2 CUAT OF WHITE & COLOUR WASH AS PER CHOICE.	
9	17CM.WIDE & 30 CM. PUCCA DRAIN AROUND THE BUILDING .	

  

TOTAL PLOT AREA	=	104.75	SQM.
NET PLOT AREA	=	104.75	SQM.
TOTAL OPEN LAND AREA	=	131.87	SQM.
GROUND FLOOR BUILT UP AREA	=	65.51	SQM.
TOTAL	=	65.51	SQM.
F.A.R.	=	0.62	
% OF COVRED AREA	=	62 %	
BUILDING HEIGHT	=	3.96 M.	

PROPOSED RESIDENTIAL BUILDING OF  
 NAME- SMT . GURIA KUMARI  
 W/O. - SRI RAVI SHANKAR YADAV  
 MOH.- DARJI BIGHA  
 MAUZA CHATRA  
 P.S. - CHATRA  
 P.S. NO.- 175  
 WARD NO. - 03  
 KHATA NO.- 244  
 H. NO.-  
 PLOT NO.- 125  
 TOUZI NO.- 28  
 DIST. - CHATRA (JHARKHAND)

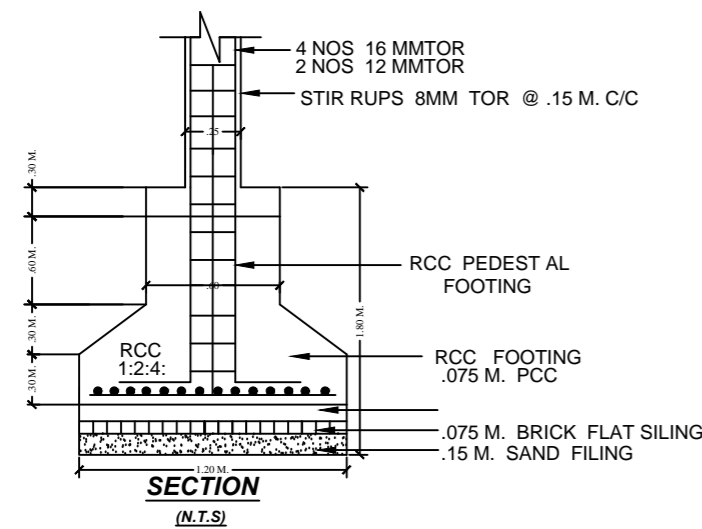

SECTION (N.T.S)

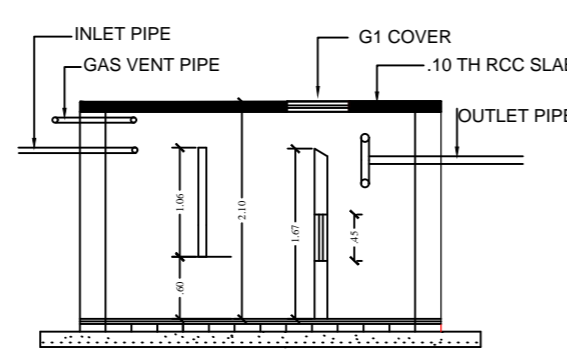

SECTION (N.T.S)

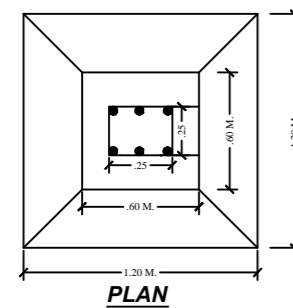

PLAN

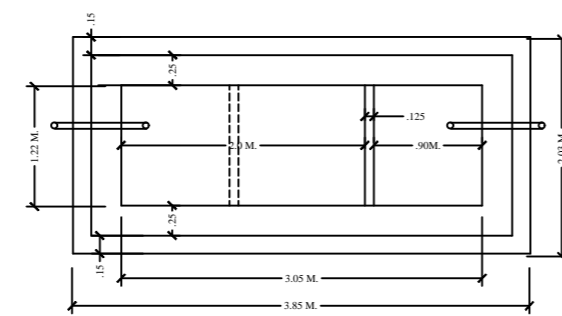

PLAN  
 DETAIL OF SEPTIC TANK

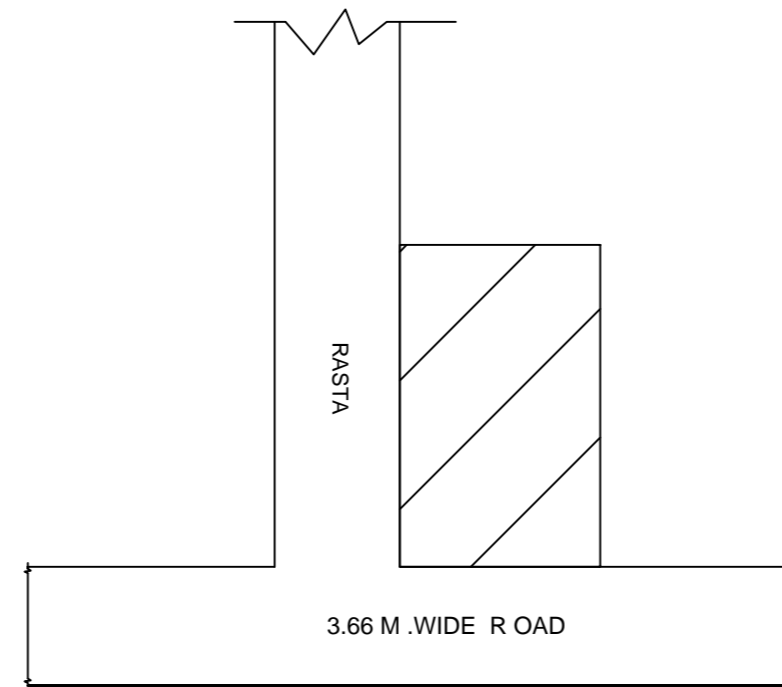

LOCATION PLAN

MAP APPROVED BY

SIGNATURE OF APPLICANT

SIGNATURE OF ENGINEER