

Proposal Basis Information	
Proposal File No	CHNP/BP/0017/W02/2024
Owner Name	AMITABH KUMAR
Khata No	33
Plot No	299,300
Village Name	Chor
Use	Commercial
SubUse	Shop

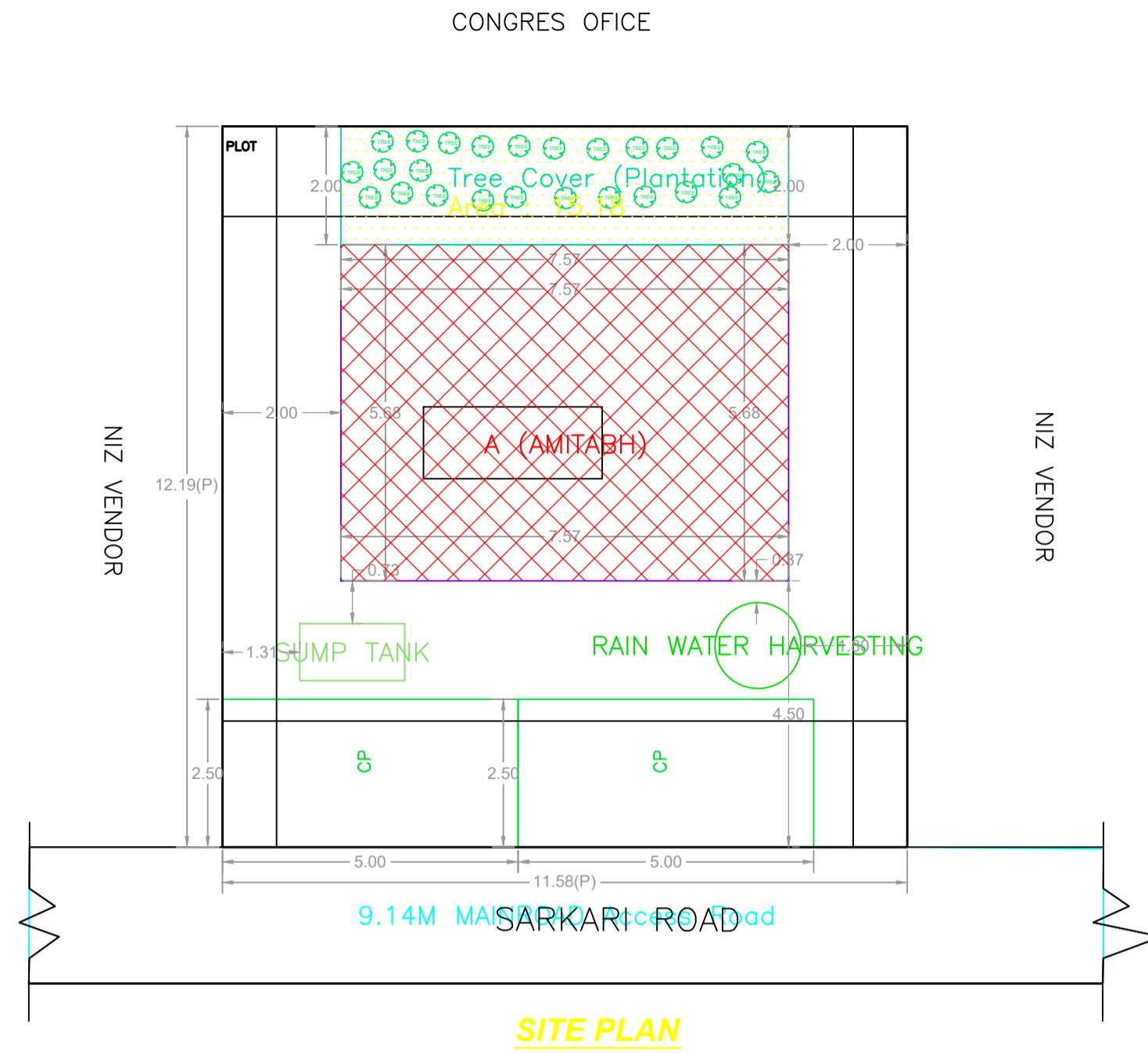

COLOR INDEX	
PLOT BOUNDARY	Black
ABUTTING ROAD	Green
PROPOSED CONSTRUCTION	Red
COMMON PLOT	Yellow
ROAD WIDENING AREA	Blue
EXISTING (To be retained)	Light Blue
EXISTING (To be demolished)	Orange

AREA STATEMENT CHATRA NAGAR PRISHAD		VERSION NO. 1.0.73
PROJECT DETAIL		VERSION DATE: 16/10/2020
Region: JHARKHAND URBAN LOCAL BODIES	Plot Use: Commercial	
District: CHATRA PRISHAD	Plot SubUse: Shop	
Authority: CHATRA NAGAR PRISHAD	PlotNearbyReligiousStructure: NA	
Inward No: CHNP/BP/0017/W02/2024	Plot/SubPlot No: 299,300	
Application Type: General Proposal	North: Plot No. - NIZ VENDOR	
Project Type: Building Permission	South: Plot No. - NIZ VENDOR	
Nature of Development: New	East: Plot No. - CONGRESH OFFIC	
Location of Development Area: Old Area	West: Road Width - 9.14	
AREA DETAILS:		SQ.MT.
AREA OF PLOT (Minimum)	(A)	141.21
NET AREA OF PLOT(Gross Plot Area - Deduction from Gross Plot area)	(A-Deductions)	141.21
Deduction for Balance Plot Area(from Gross Plot Area)		
Common Plot		15.18
Total		15.18
BALANCE AREA OF PLOT(Net Plot Area - Recreational/Amenity space)	(A-Deductions)	126.04
PLOT AREA FOR COVERAGE(Net Plot Area)	(A-Deductions)	141.21
Plot Area for FAR (Net Plot Area + RoadWidening Area)	(A-Deductions)	141.21
COVERAGE CHECK		
Permissible Coverage area (50.00 %)		70.61
Proposed Coverage Area (30.49 %)		43.05
Total Prop. Coverage Area (30.49 %)		43.05
Balance coverage area (19.52 %)		27.56
FAR CHECK		
Perm. FAR Area (2.00)		282.42
Total Perm. FAR area		282.42
Commercial FAR		86.10
Proposed FAR Area		95.97
Total Proposed FAR Area		95.97
Consumed FAR (Factor)		0.68
Balance FAR Area		186.45
BUILT UP AREA CHECK		
Total Proposed BuiltUp Area		129.15
ARCHITECT (Regd)		LAW CHATURVEDI
ENGINEER (Regd)		
SUPERVISOR (Regd)		
OWNER (Regd)		AMITABH KUMAR
DEVELOPMENT AUTHORITY		LOCAL BODY

Building USE/SUBUSE Details

Building Name	Building Use	Building SubUse	Building Structure	Floor Name	Floor Use	Floor SubUse	FAR Name	FAR Use	FAR SubUse
A (AMITABH)	Commercial	Shop	Non-Highrise	GROUND FLOOR PLAN	Commercial	Shop	-	-	-
				TYPICAL 1 & 2 FLOOR PLAN	Commercial	Shop	Commercial FAR	Commercial	Shop
				TERRACE FLOOR PLAN	Commercial	Shop	-	-	-

Buildingwise Floor FAR Details

Floor Name	Building Name A (AMITABH)		Total	
	Proposed Built Up Area (Sq.mt.)	Proposed FAR Area (Sq.mt.)	Total Proposed Built Up Area (Sq.mt.)	Total FAR Area (Sq.mt.)
Ground Floor	43.05	9.86	43.05	9.86
First Floor	43.05	43.05	43.05	43.05
Second Floor	43.05	43.05	43.05	43.05
Terrace Floor	0.00	0.00	0.00	0.00
Total :	129.15	95.96	129.15	95.96

FAR & Tenement Details (Table 4c-1)

Building	No. of Same Bldg	Total Built Up Area (Sq.mt.)	Deductions (Area in Sq.mt.)	Proposed FAR Area (Sq.mt.)	Add Area In FAR (Sq.mt.)	Total FAR Area (Sq.mt.)	Total Consumed Additional FAR Area (Sq.mt.)	Trmt (No.)
			Parking					
A (AMITABH)	1	129.15	33.19	86.10	9.86	95.96	95.96	02
Grand Total :	1	129.15	33.19	86.10	9.86	95.96	95.96	02

Required Parking(Table 7a)

Building Name	Type	SubUse	Area (Sq.mt.)	Units		Car		TwoWheeler	
				Reqd.	Prop.	Reqd./Unit	Prop.	Reqd./Unit	Reqd.
A (AMITABH)	Commercial	Shop	>0	50	66.38	1	1	-	-
Total :			-	-	-	1	2	-	3

Parking Check (Table 7b)

Vehicle Type	Reqd.		Prop.	
	No.	Area	No.	Area
Car	-	-	2	25.00
Total Car	1	12.50	2	25.00
TwoWheeler	-	-	5	10.00
Total TwoWheeler	3	6.00	5	10.00
Other Parking	-	-	-	23.19
Total	-	18.50	-	68.19

LTP NAME AND SIGNATURE	STRUCTURAL ENG'S NAME AND SIGNATURE	BUILDER NAME AND SIGNATURE	DIGITAL SIGNATURE
LAW CHATURVEDI CHNP/ENG/0004/2017			



Proposal Basic Information	
Proposal File No.	CHNP/BP/0017/W02/2024
Owner Name	AMITABH KUMAR
Khata No	33
Plot No	299,300
Village Name	Chor
Use	Commercial
SubUse	Shop

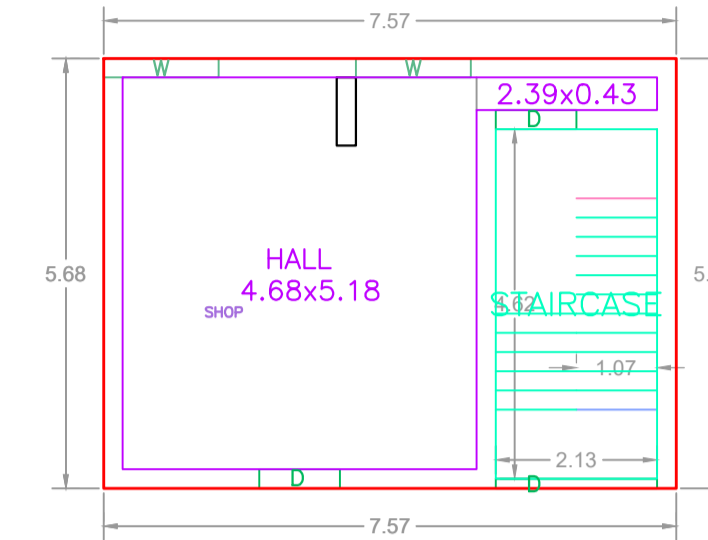
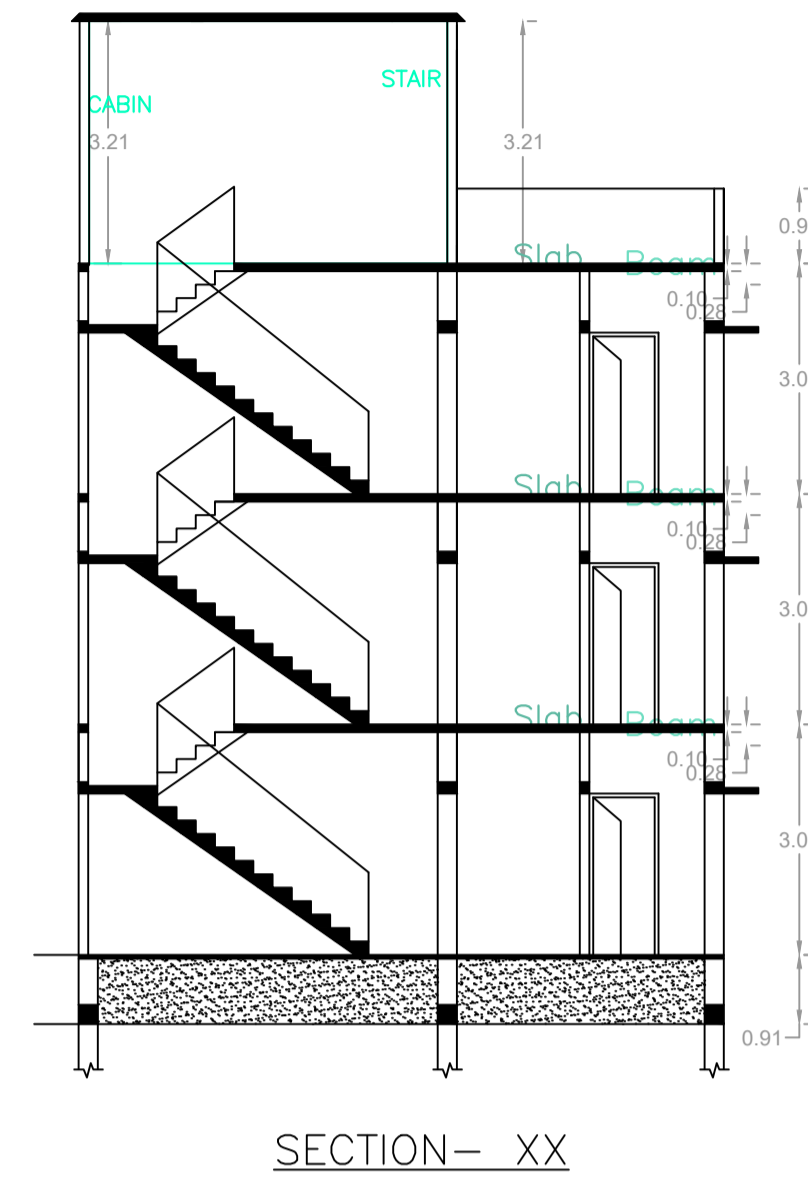
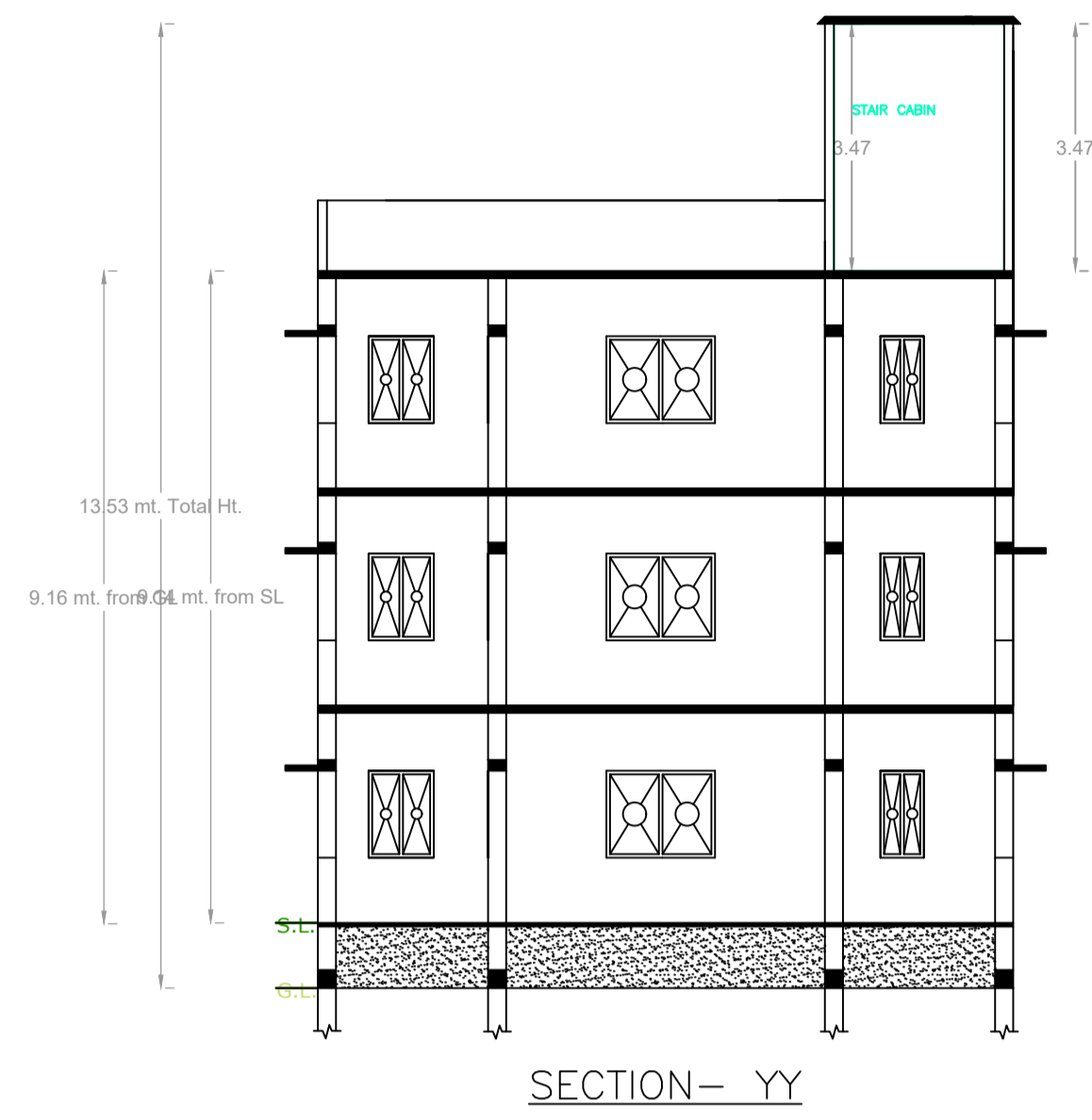

UnitBUA Table for Building :A (AMITABH)

FLOOR	Name	UnitBUA Type	UnitBUA Area	Carpet Area	No. of Rooms	No. of Tenement
TYPICAL - 1& 2 FLOOR PLAN	SHOP	SHOP	25.28	25.05	1	2
Total:	-	-	50.57	50.11	2	2

SCHEDULE OF DOOR:

BUILDING NAME	NAME	LENGTH	HEIGHT	NOS
A (AMITABH)	D	1.07	2.10	04

SCHEDULE OF WINDOW/VENTILATION:

BUILDING NAME	NAME	LENGTH	HEIGHT	NOS
A (AMITABH)	W	1.52	1.20	04

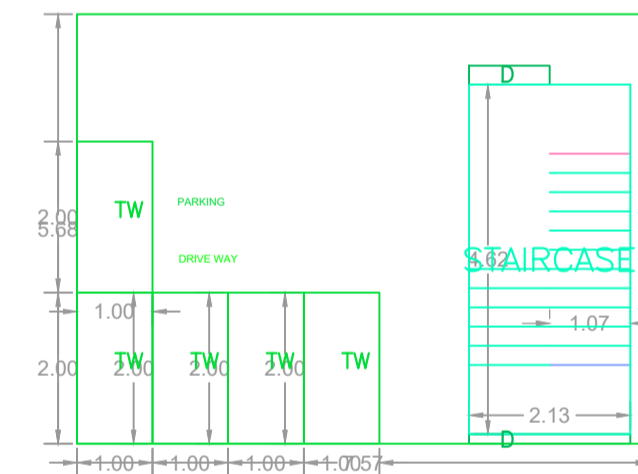
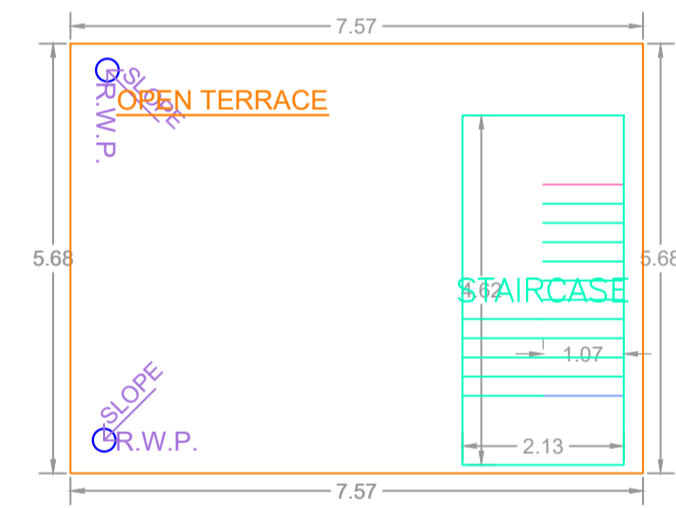

Building :A (AMITABH)

Floor Name	Total Built Up Area (Sq.mt.)	Deductions (Area in Sq.mt.)		Proposed FAR Area (Sq.mt.)	Add Area In FAR (Sq.mt.)	Total FAR Area (Sq.mt.)	Total Consumed Additional FAR Area (Sq.mt.)	Tnmt (No.)
		Parking	Commercial					
Ground Floor	43.05	33.19	0.00	9.86	9.86	9.86	00	
First Floor	43.05	0.00	43.05	0.00	43.05	43.05	01	
Second Floor	43.05	0.00	43.05	0.00	43.05	43.05	01	
Terrace Floor	0.00	0.00	0.00	0.00	0.00	0.00	00	
Total :	129.15	33.19	86.10	9.86	95.96	95.96	02	
Total Number of Same Buildings :	1							
Total :	129.15	33.19	86.10	9.86	95.96	95.96	02	

LTP NAME AND SIGNATURE	STRUCTURAL ENG'S NAME AND SIGNATURE	BUILDER NAME AND SIGNATURE	DIGITAL SIGNATURE
LAW CHATURVEDI CHNP/ENG/0004/2017			



DATE	22-10-2024
SHEET NO.	3

Proposal Basis Information	
Proposal File No.	CHNP/BP/0017/W02/2024
Owner Name	AMITABH KUMAR
Khata No	33
Plot No	299,300
Village Name	Chor
Use	Commercial
SubUse	Shop

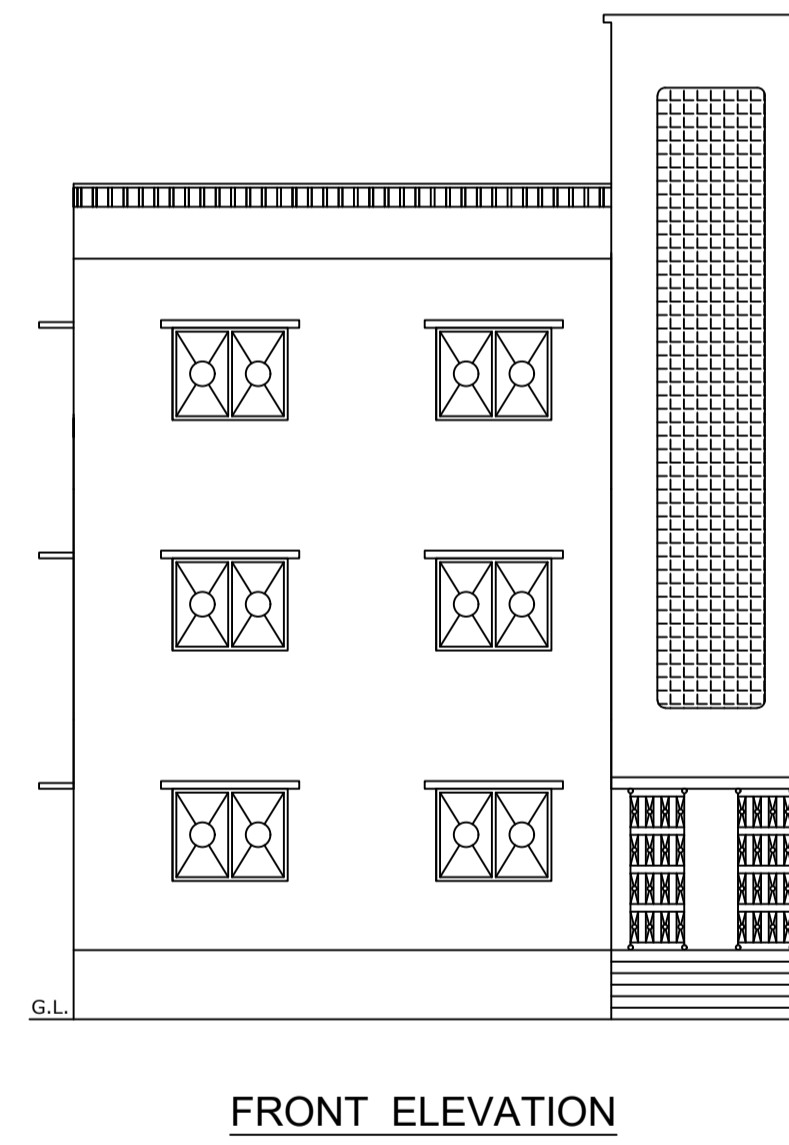
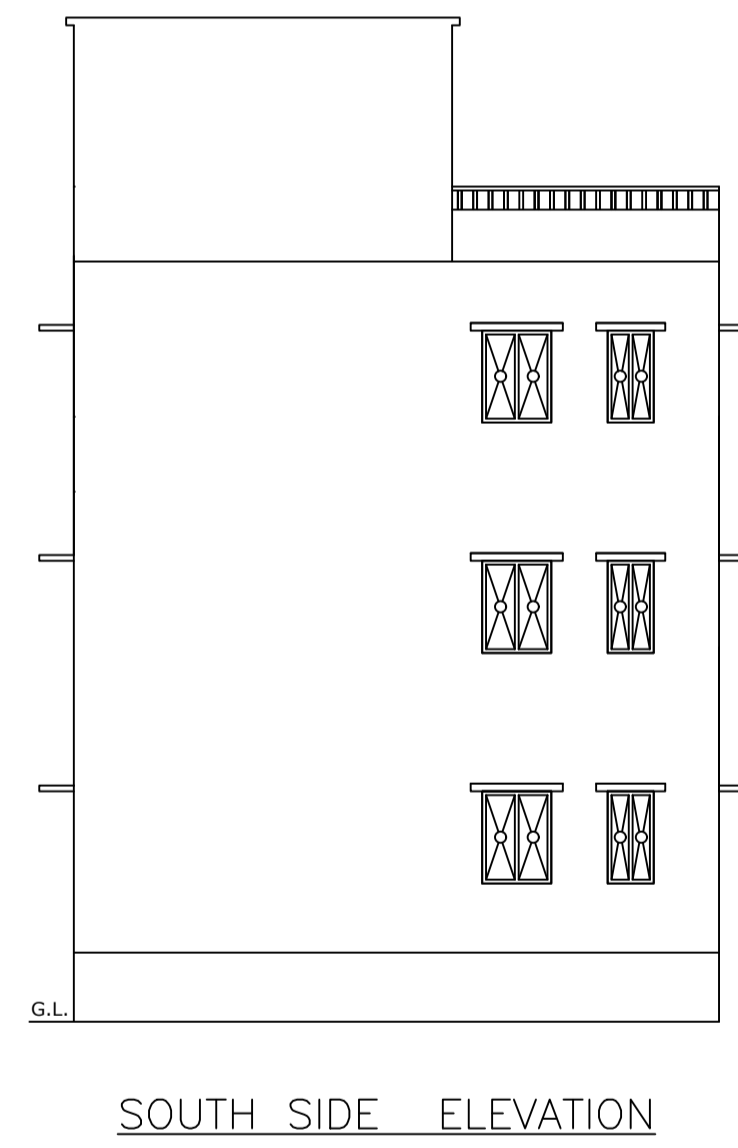
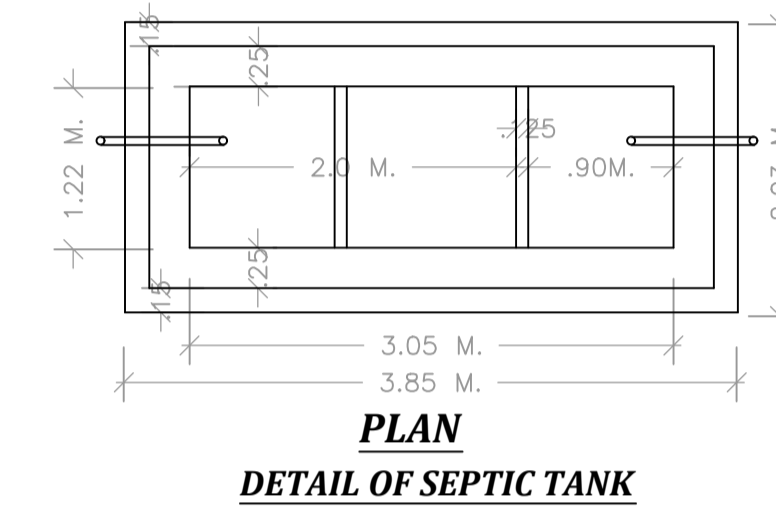
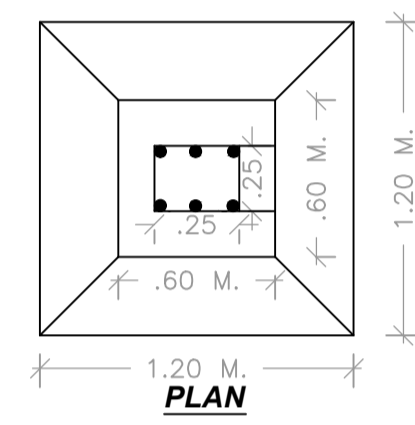
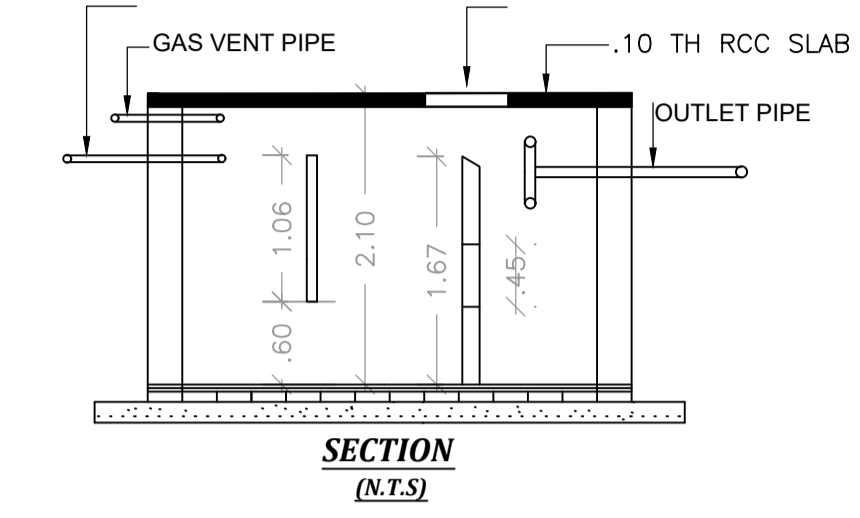
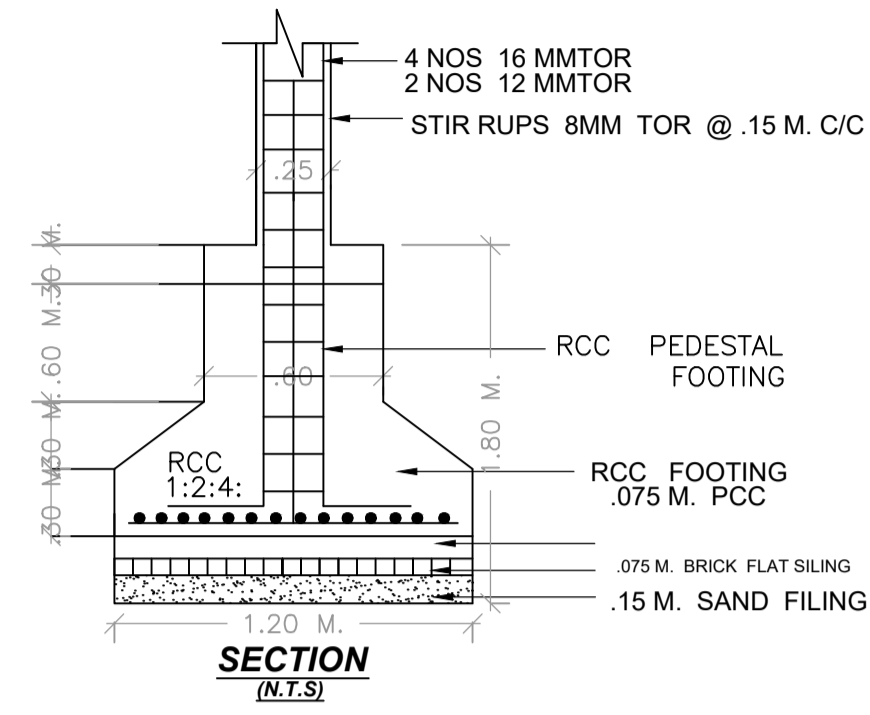
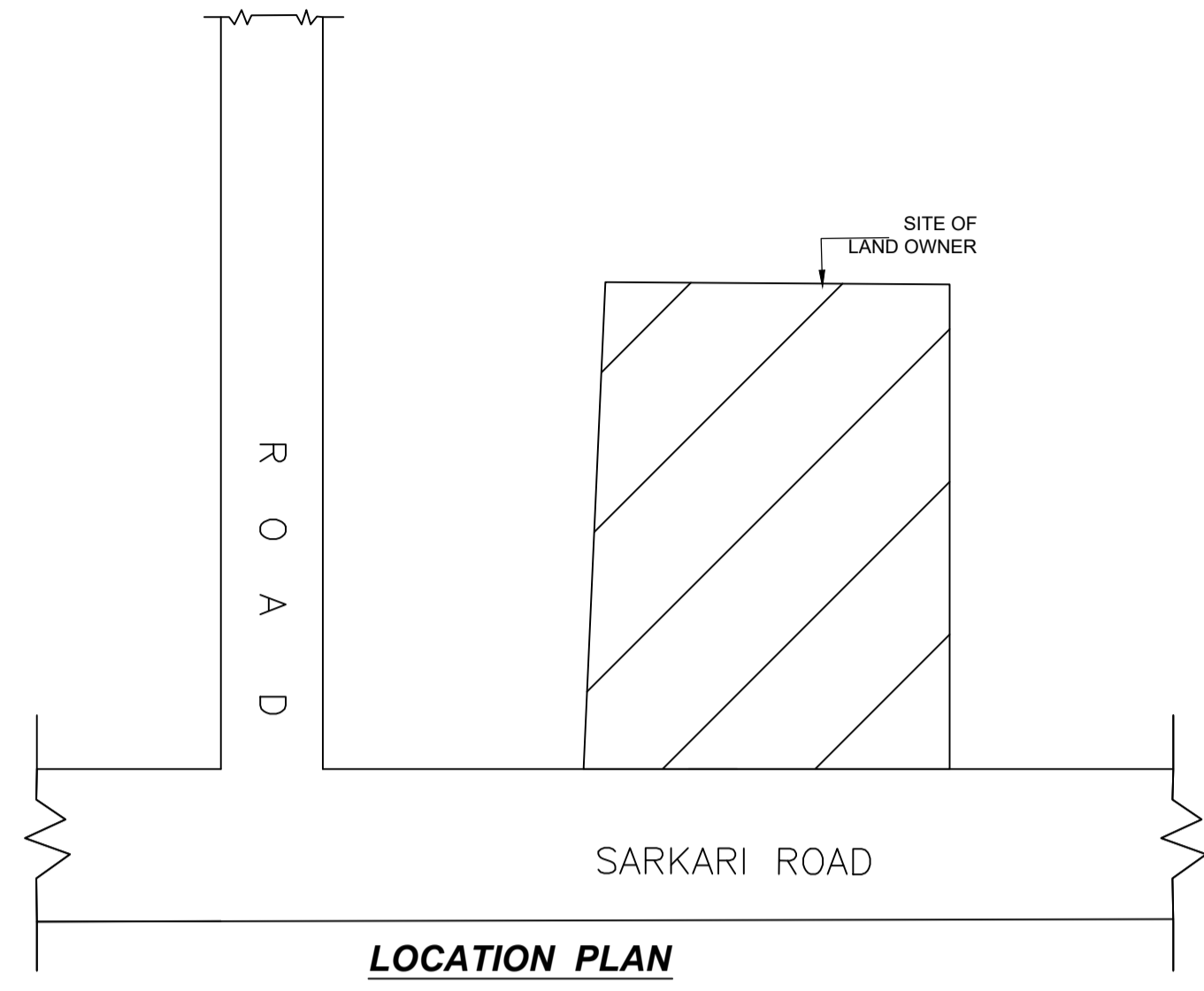

LTP NAME AND SIGNATURE	STRUCTURAL ENG'S NAME AND SIGNATURE	BUILDER NAME AND SIGNATURE	DIGITAL SIGNATURE
LAW CHATURVEDI CHNP/ENG/0004/2017			