

Proposal Basic Information	
Proposal File No.	CNP/BP/0004/W18/2019
Owner Name	SMT. BHAGWATI DEVI
Khata No	61
Plot No	70/310
Village Name	Amla Tola
Use	Residential
SubUse	Bungalow/ Dwelling / Non Apartment

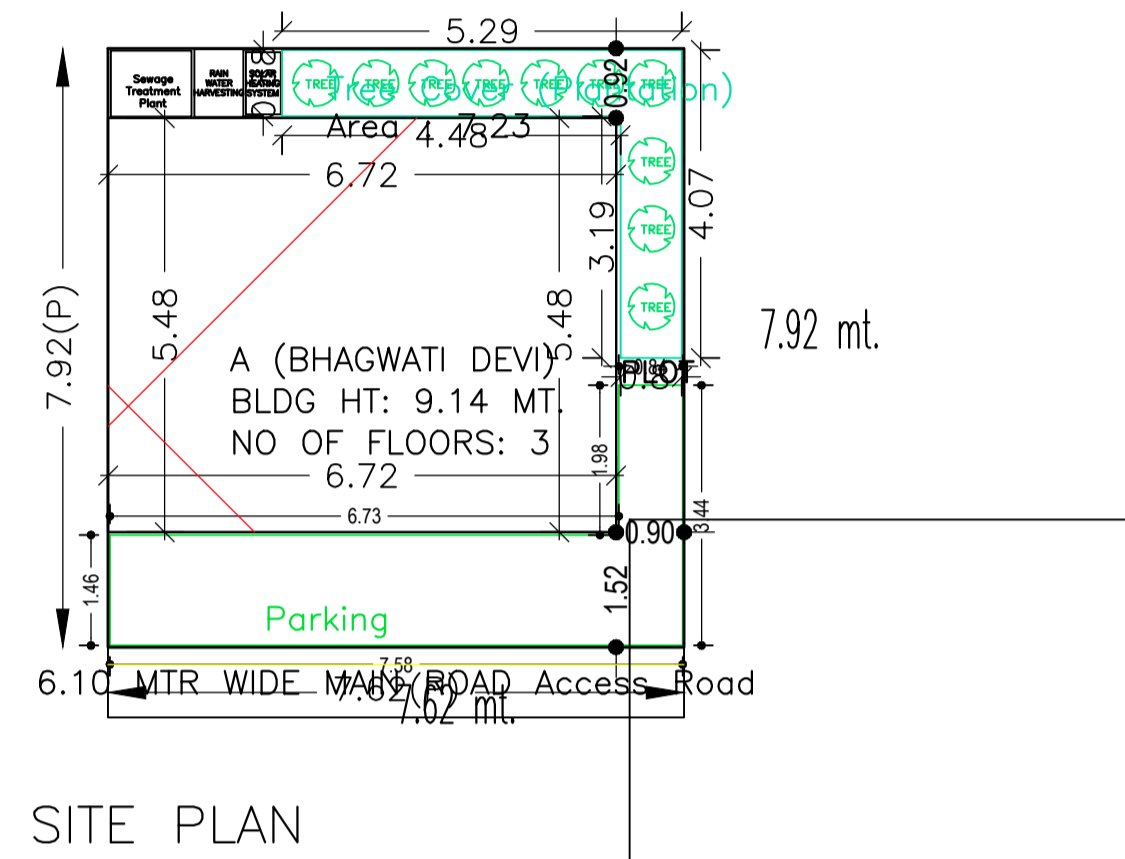

AREA STATEMENT		VERSION NO. : 1.0.35
CHAIBASA NAGAR		VERSION DATE: 13/03/2019
PARISHAD		
PROJECT DETAIL:		
Region: JHARKHAND URBAN LOCAL BODIES	Plot Use: Residential	
District: WEST SINGHBHUM	Plot SubUse: Bungalow/ Dwelling / Non Apartment	
Authority: CHAIBASA NAGAR PARISHAD	PlotNearbyReligiousStructure: NA	
Inward No: CNP/BP/0004/W18/2019	Plot/SubPlot No: 70/310	
Application Type: General Proposal	North Road Width - GALLI	
Project Type: Building Permission	South Plot No. - BANWARI LAL	
Nature of Development: New	East: Plot No. -76	
Location of Development Area: New Area	West: Road Width - GALLI	
AREA DETAILS:		SQ.MT.
AREA OF PLOT (Minimum)	(A)	60.35
NET AREA OF PLOT(Gross Plot Area - Deduction from Gross Plot area)	(A-Deductions)	60.35
Deduction for Balance Plot Area(from Gross Plot Area)		
Common Plot		7.23
Total		7.23
BALANCE AREA OF PLOT(Net Plot Area - Recreational/Amenity space)	(A-Deductions)	53.12
PLOT AREA FOR COVERAGE(Net Plot Area)	(A-Deductions)	60.35
Plot Area for FAR (Net Plot Area + RoadWidening Area)	(A-Deductions)	60.35
COVERAGE CHECK		
Permissible Coverage area (70.00 %)		42.24
Proposed Coverage Area (61.03 %)		36.83
Total Prop. Coverage Area (61.03 %)		36.83
Balance coverage area (8.96 %)		5.41
FAR CHECK		
Perm. FAR Area (2.00)		120.70
Total Perm. FAR area		120.70
Residential FAR		110.48
Proposed FAR Area		110.48
Total Proposed FAR Area		110.48
Consumed FAR (Factor)		1.83
Balance FAR Area		10.22
BUILT UP AREA CHECK		
Total Proposed BuiltUp Area		110.49
ARCHITECT (Regd)	KUNAL GUIN	
ENGINEER (Regd)		
SUPERVISOR (Regd)		
OWNER (Regd)	SMT. BHAGWATI DEVI	
DEVELOPMENT AUTHORITY		LOCAL BODY

COLOR INDEX	
PLOT BOUNDARY	Black
ABUTTING ROAD	Green
PROPOSED CONSTRUCTION	Red
COMMON PLOT	Yellow
ROAD WIDENING AREA	Orange
EXISTING (To be retained)	Blue
EXISTING (To be demolished)	Light Blue

Buildingwise Floor FAR Details

Floor Name	A (BHAGWATI DEVI)			
	Ground Floor		36.83	36.83
Second Floor	36.83		36.83	
Total :	110.49	110.49	110.49	

Building USE/SUBUSE Details

Building Name	Building Use	Building SubUse	Building Structure
A (BHAGWATI DEVI)	Residential	Bungalow/ Dwelling / Non Apartment	Non-Highrise

FAR & Tenement Details (Table 4c-1)

Building	No. of Same Bldg	Total Built Up Area (Sq.mt.)	Proposed FAR Area (Sq.mt.) Resi.	Total FAR Area (Sq.mt.)	Total Consumed Additional FAR Area (Sq.mt.)	Tnmt (No.)
A (BHAGWATI DEVI)	1	110.49	110.49	110.49	110.49	01
Grand Total :	1	110.49	110.49	110.49	110.49	01

LTP NAME AND SIGNATURE	STRUCTURAL ENG'S NAME AND SIGNATURE	BUILDER NAME AND SIGNATURE	DIGITAL SIGNATURE
KUNAL GUIN CNP/ENG/0006/2017			

Proposal Basic Information	
Proposal File No.	CNP/BP/0004/W18/2019
Owner Name	SMT. BHAGWATI DEVI
Khata No	61
Plot No	70/310
Village Name	Amla Tola
Use	Residential
SubUse	Bungalow/ Dwelling / Non Apartment

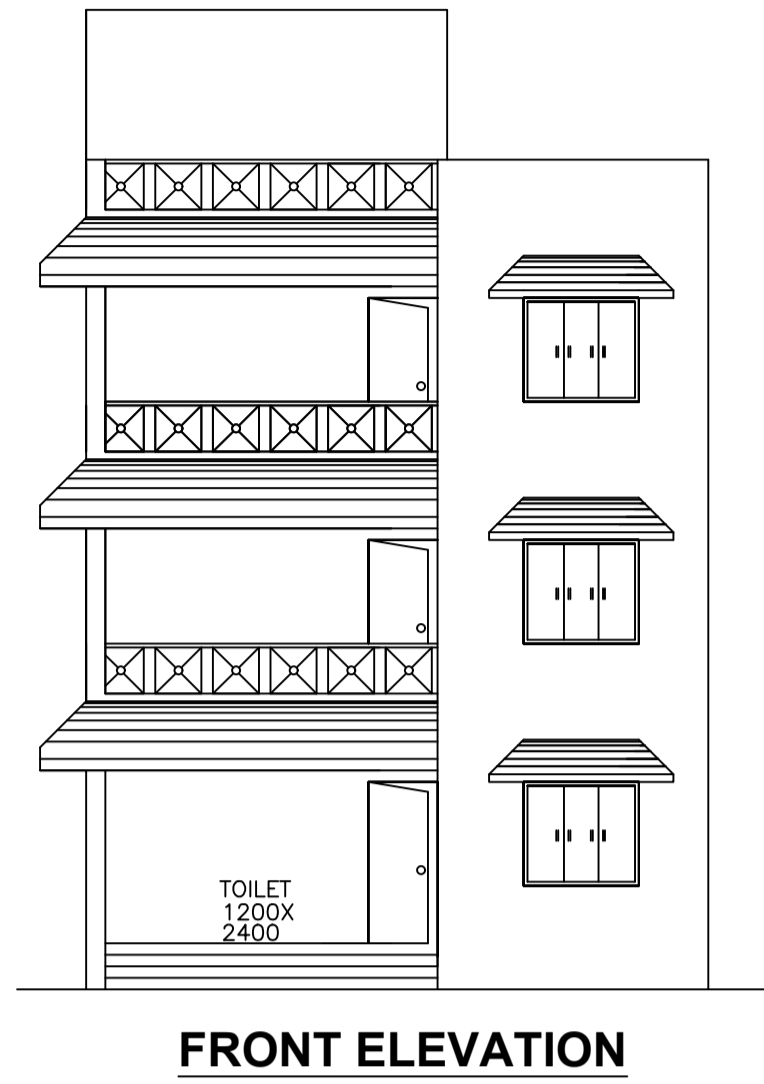
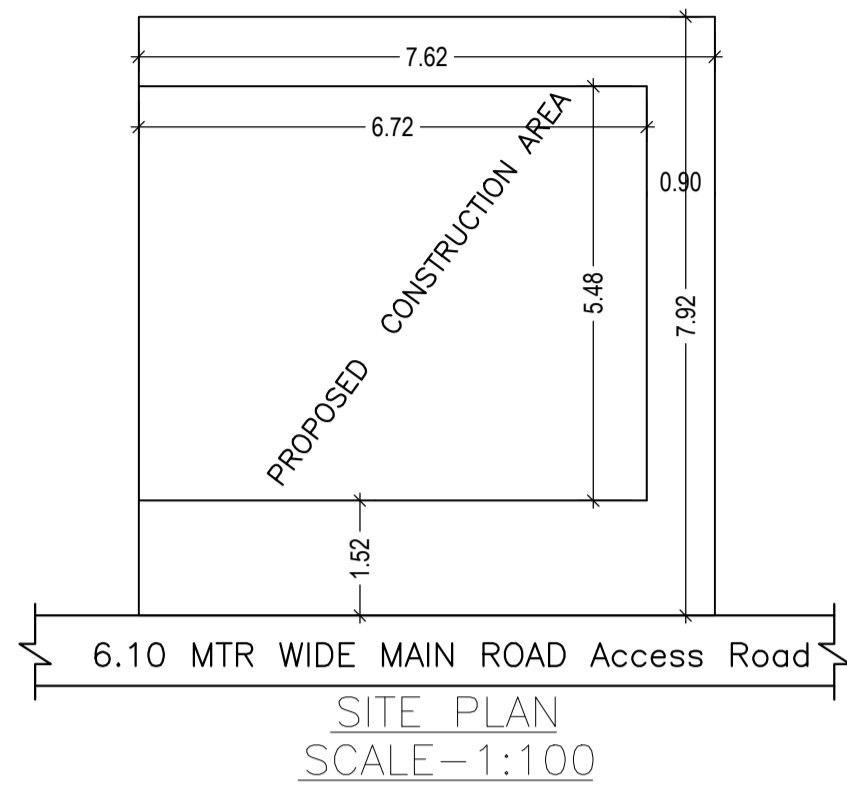

DETAILS OF RAIN WATER HARVESTING STRUCTURES

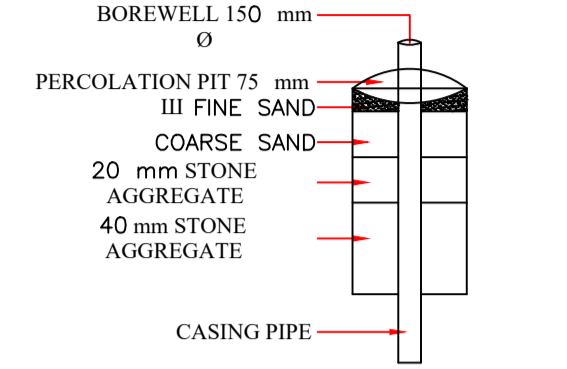

CROSS SECTION OF RAIN WATER 1.00M DIA PERCOLATION WELL FOR RECHARGING BORE WELL

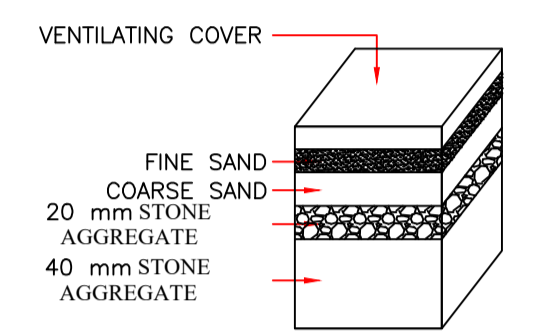

CROSS SECTION OF PERCOLATION PIT/TRENCH OF RAIN WATER

SCALE = N.T.S.

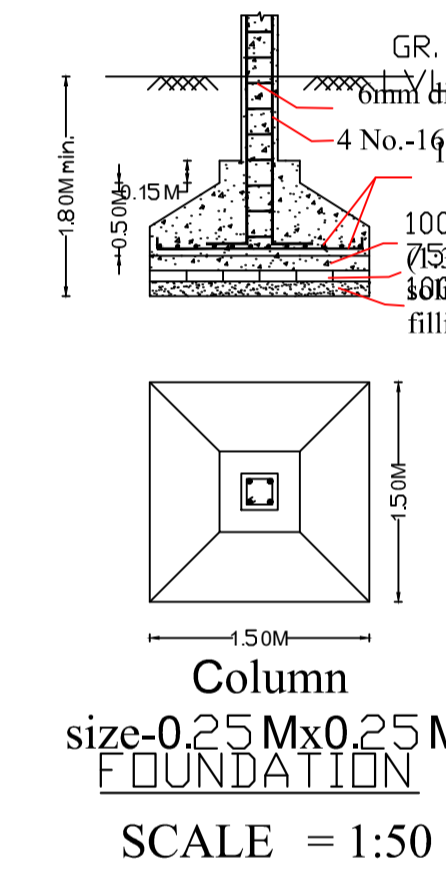
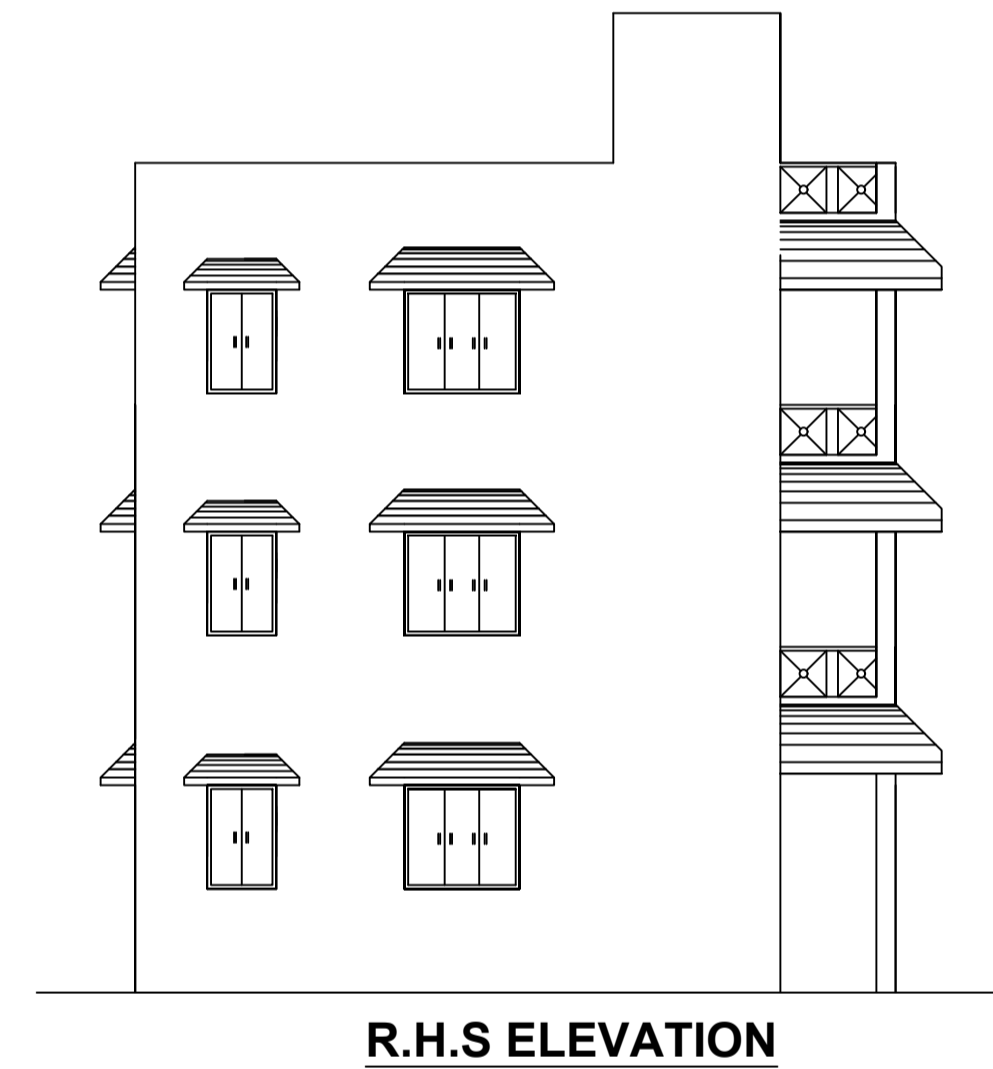
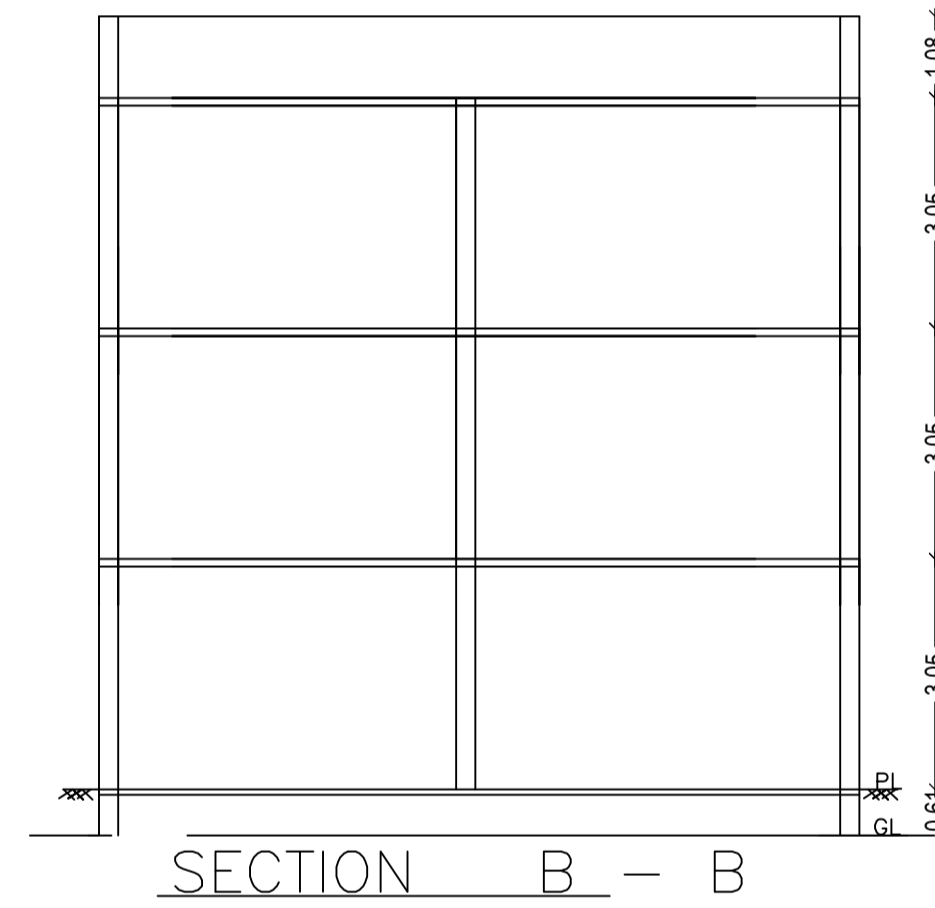
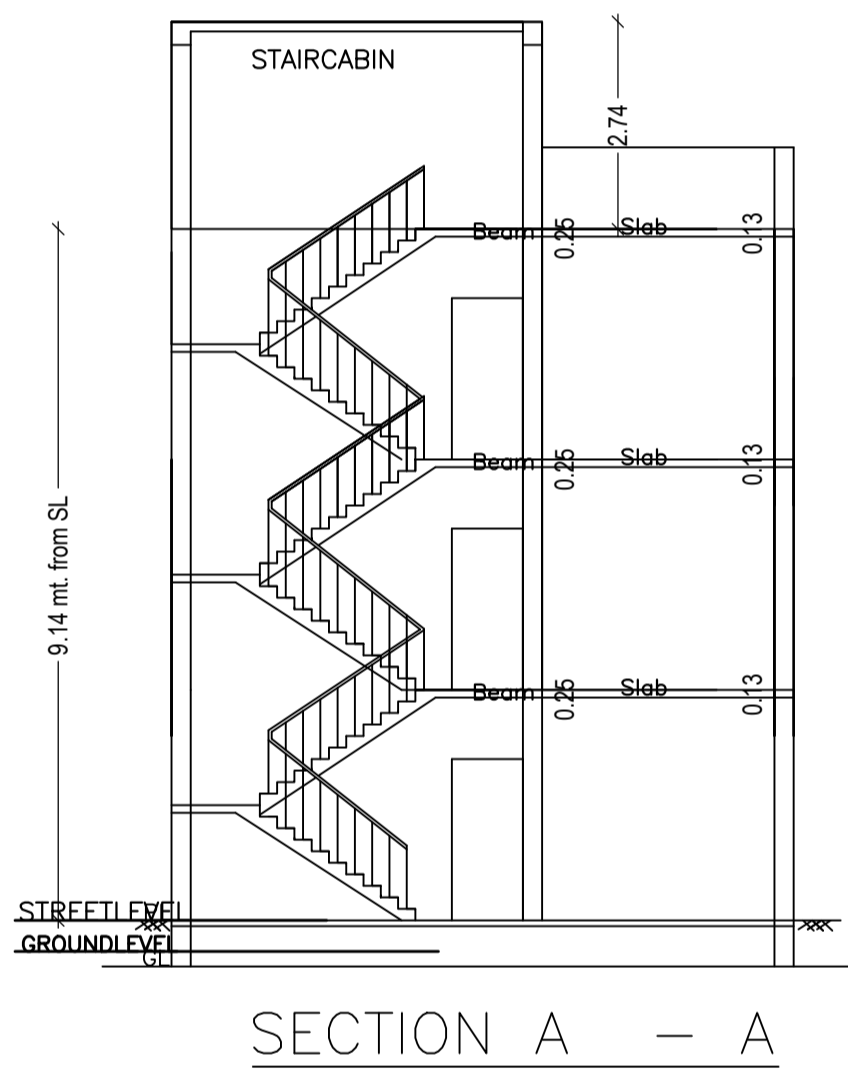
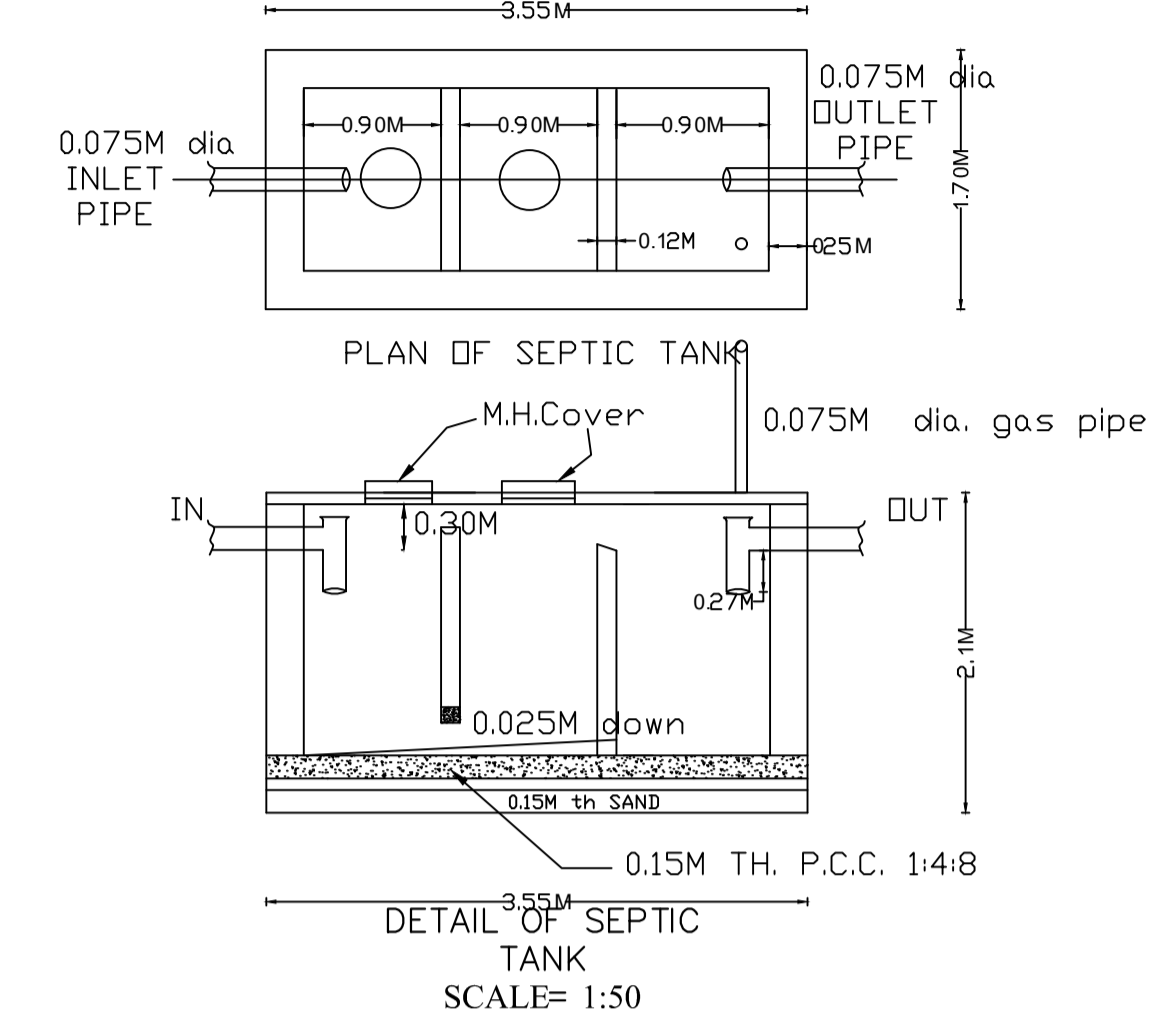

UnitBUA Table for Building :A (BHAGWATI DEVI)

FLOOR	Name	UnitBUA Type	UnitBUA Area	Carpet Area	No. of Rooms	No. of Tenement
GROUND FLOOR PLAN	SPLIT A	FLAT	73.91	73.54	3	1
FIRST FLOOR PLAN	SPLIT A	FLAT	0.00	0.00	3	0
SECOND FLOOR PLAN	SPLIT A	FLAT	0.00	0.00	3	0
Total:	-	-	73.91	73.54	9	1

SCHEDULE OF DOOR:

BUILDING NAME	NAME	LENGTH	HEIGHT	NOS
A (BHAGWATI DEVI)	D1	0.75	2.13	06
A (BHAGWATI DEVI)	D	0.90	2.13	03

SCHEDULE OF WINDOW/VENTILATION:

BUILDING NAME	NAME	LENGTH	HEIGHT	NOS
A (BHAGWATI DEVI)	V	0.60	2.70	03
A (BHAGWATI DEVI)	W1	0.90	2.70	03
A (BHAGWATI DEVI)	W	1.50	2.70	06

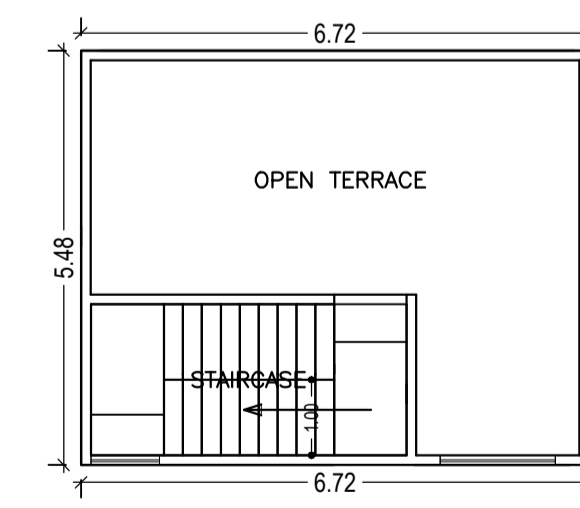
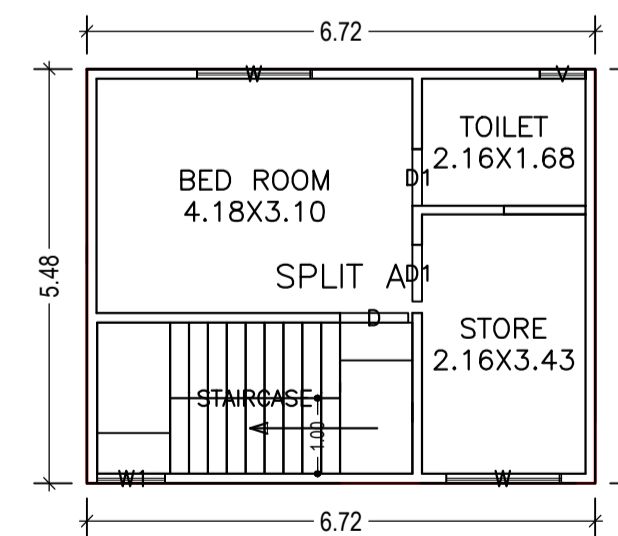
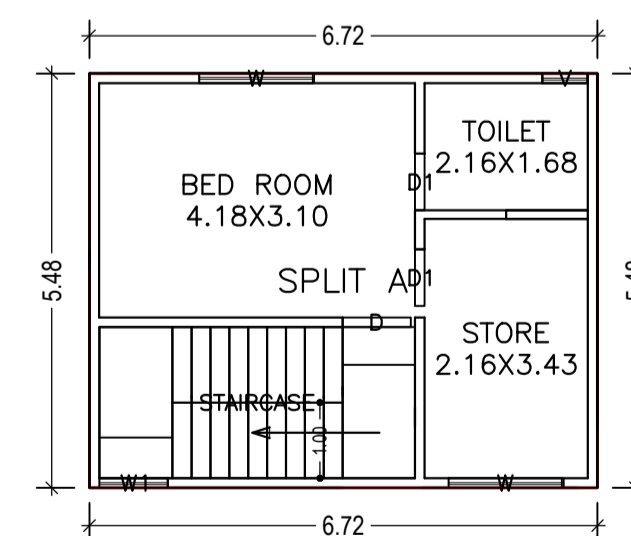
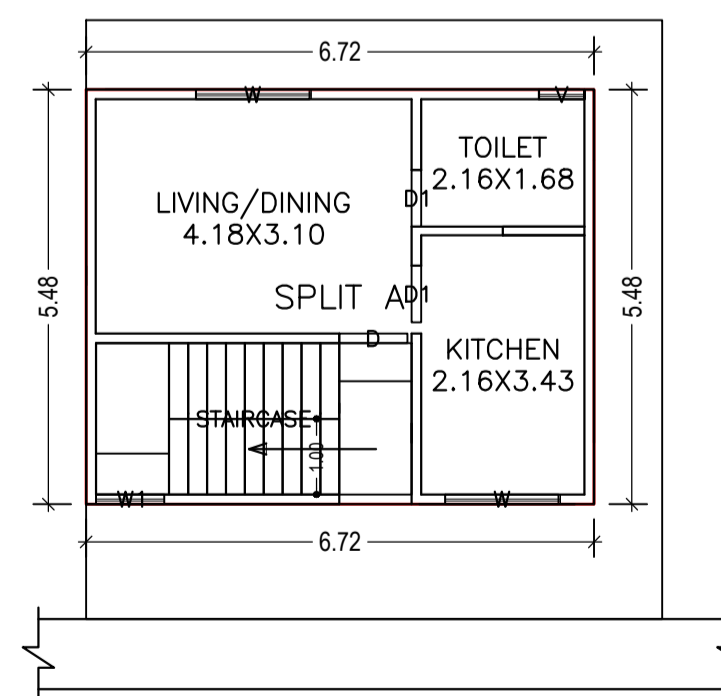

Building :A (BHAGWATI DEVI)

Floor Name	Total Built Up Area (Sq.mt.)	Proposed FAR Area (Sq.mt.) Res.	Total FAR Area (Sq.mt.)	Total Consumed Additional FAR Area (Sq.mt.)	Trmt (No.)
Ground Floor	36.83	36.83	36.83	36.83	01
First Floor	36.83	36.83	36.83	36.83	00
Second Floor	36.83	36.83	36.83	36.83	00
Terrace Floor	0.00	0.00	0.00	0.00	00
Total:	110.49	110.49	110.49	110.49	01
Total Number of Same Buildings	1				
Total:	110.49	110.49	110.49	110.49	01

LTP NAME AND SIGNATURE	STRUCTURAL ENG'S NAME AND SIGNATURE	BUILDER NAME AND SIGNATURE	DIGITAL SIGNATURE
KUNAL GUIN CNP/ENG/0006/2017			