

Project Title :SARAD KUMAR SINGH

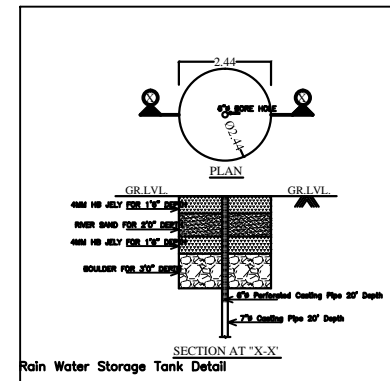

PROPOSED BUILDING FOR:-
01. SRI SARAD KUMAR SINGH
S/O- LATE FAKIRCHAND SINGH
AT- SADAR CHAIBASA, WEST SINGHBHUM,
JHARKHAND
P.O.- CHAIBASA
P.S.- SADAR
WARD NO.- 17(NEW)
THANA NO.-644
KHATA NO.- 95
PLOT NO.- 2175
MOUZA.- SADAR BAZAR
WEST SINGHBHUM (JHARKHAND)

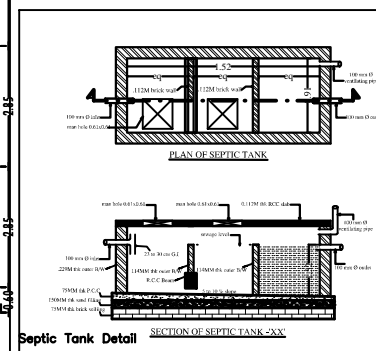
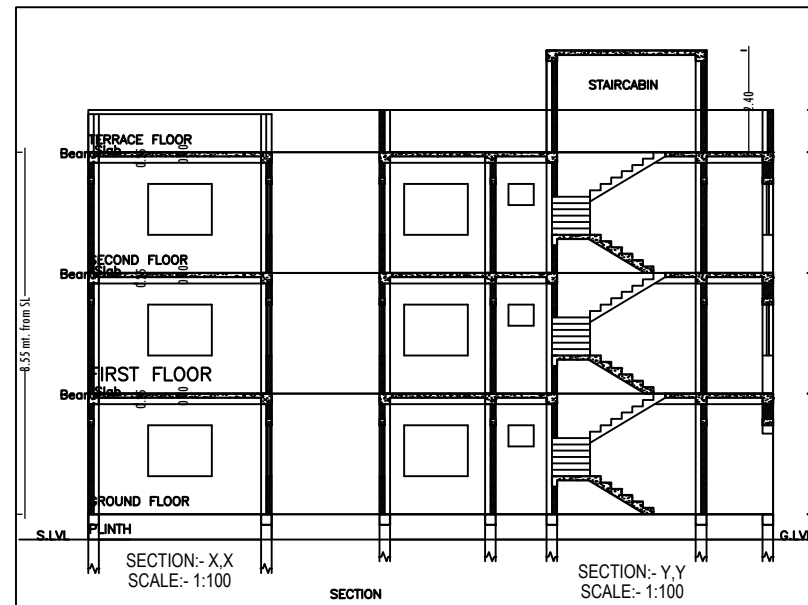
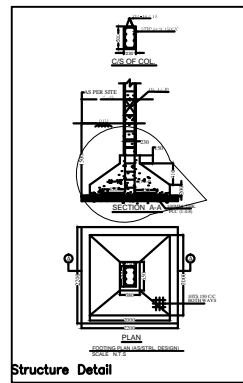
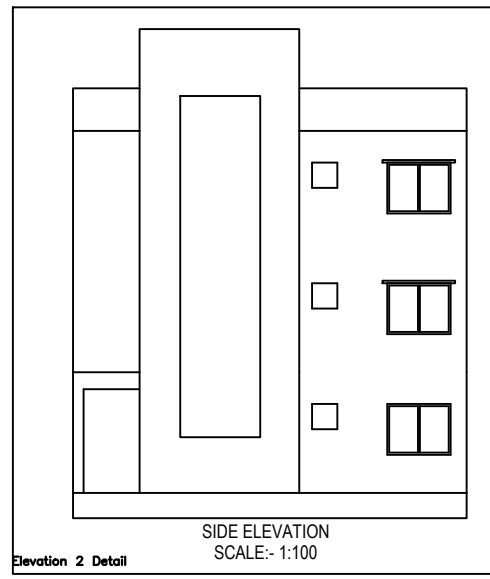
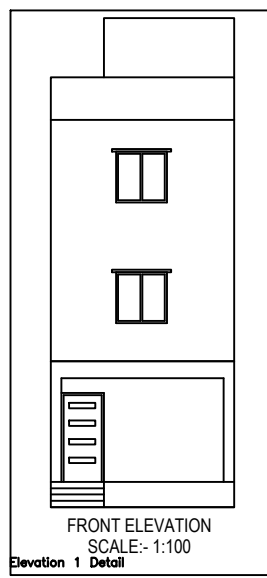
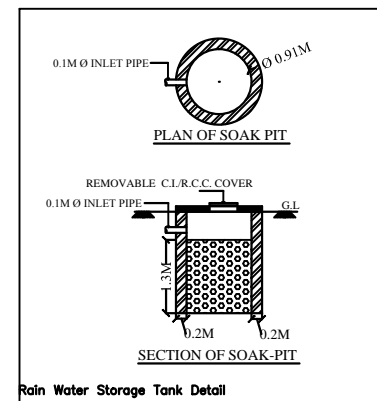
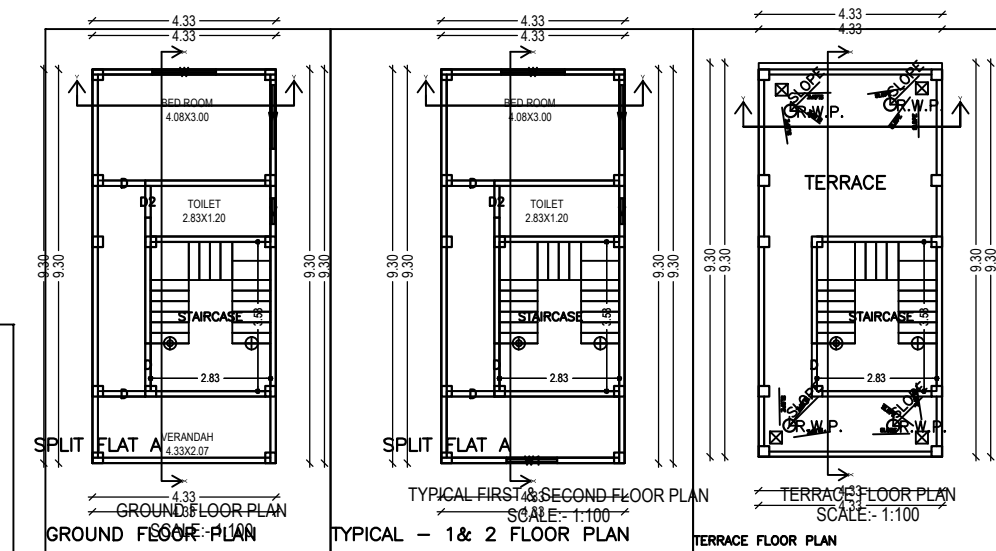

SIGNATURE OF OWNER

SIGNATURE OF ENGINEER

SITE PLAN, FLOOR PLANS, ELEVATIONS (2-nos.),
SECTIONS (2-nos.), AREA CALCULATION,
LOCATION
PLAN, DRAINAGE PLAN, FOOTING DETAILS &
WATER TANK

SHEET NO. = 1/1

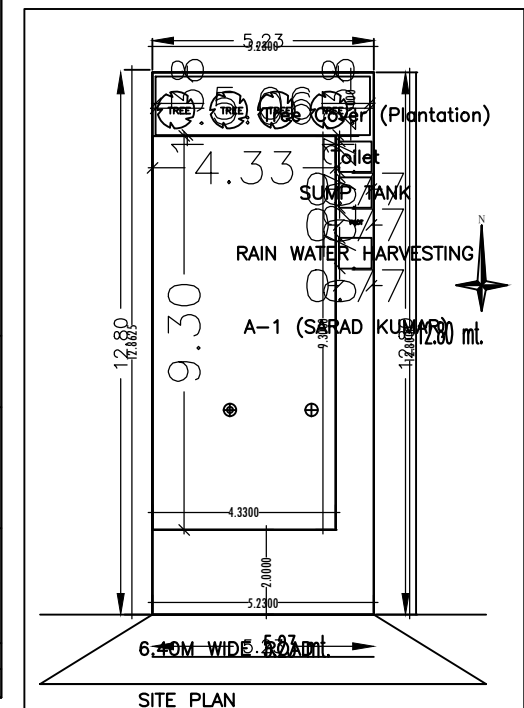

Building :A (SARAD KUMAR)

Floor Name Proposed FAR Area