

FAR & Tenement Details (Table 4c-1)

Building	No. of Same Bldg	Total Built Up Area (Sq.mt.)	Deductions (Area in Sq.mt.)		Proposed FAR Area (Sq.mt.)	Total FAR Area (Sq.mt.)	Total Consumed Additional FAR Area (Sq.mt.)	Trnmt (No.)
			Void	Resi.				
A (SMT REETA VERMA)	1	39.06	0.90		38.16	38.16	38.16	01
Grand Total :	1	39.06	0.90		38.16	38.16	38.16	01

Proposal Basic Information

Proposal File No.	CNP/BB/0017/W01/2021
Owner Name	REETA VERMA
Khata No	06
Plot No	152
Village Name	Pulhatu
Use	Residential
SubUse	Bungalow/ Dwelling / Non Apartment

AREA STATEMENT		VERSION NO. : 1.0.55
CHAIBASA NAGAR PARISHAD		VERSION DATE: 16/10/2020
PROJECT DETAIL:		
Region: JHARKHAND URBAN LOCAL BODIES	Plot Use: Residential	
District: WEST SINGHBHUM	Plot SubUse: Bungalow/ Dwelling / Non Apartment	
Authority: CHAIBASA NAGAR PARISHAD	PlotNearby/ReligiousStructure: NA	
Inward No: CNP/BB/0017/W01/2021	PlotSubPlot No: 152	
Application Type: General Proposal	North: Road Width - road and part of plot no. 152	
Project Type: Building Permission	South: Plot No. - sub plot no. 21B	
Nature of Development: New	East: Road Width - road and part of plot no. 152	
Location of Development Area: Old Area	West: Plot No. - sub plot no. 16	
AREA DETAILS:		
AREA OF PLOT (Minimum)	(A)	65.04
NET AREA OF PLOT(Gross Plot Area - Deduction from Gross Plot area)	(A-Deductions)	65.04
Deduction for Balance Plot Area(from Gross Plot Area)		
Common Plot		9.48
Total		9.48
BALANCE AREA OF PLOT(Net Plot Area - Recreational/Amenity space)	(A-Deductions)	55.56
PLOT AREA FOR COVERAGE(Net Plot Area)	(A-Deductions)	65.04
Plot Area for FAR (Net Plot Area + Road Widening Area)	(A-Deductions)	65.04
COVERAGE CHECK		
Permissible Coverage area (70.00 %)		45.53
Proposed Coverage Area (60.06 %)		39.06
Total Prop. Coverage Area (60.06 %)		39.06
Balance coverage area (9.95 %)		6.47
FAR CHECK		
Perm. FAR Area (1.50)		97.56
Total Perm. FAR area		97.56
Residential FAR		38.16
Proposed FAR Area		38.16
Total Proposed FAR Area		38.16
Consumed FAR (Factor)		0.59
Balance FAR Area		59.40
BUILT UP AREA CHECK		
Total Proposed BuiltUp Area		39.06
ARCHITECT (Regd)		KUNAL GUIN
ENGINEER (Regd)		
SUPERVISOR (Regd)		
OWNER (Regd)		REETA VERMA
DEVELOPMENT AUTHORITY		LOCAL BODY

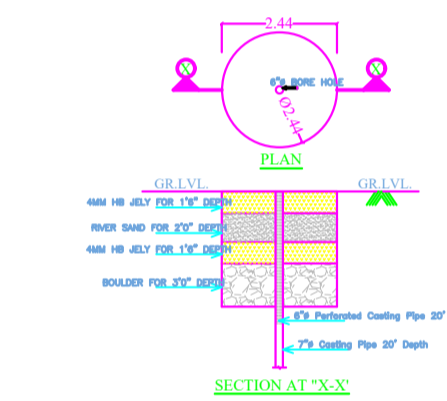
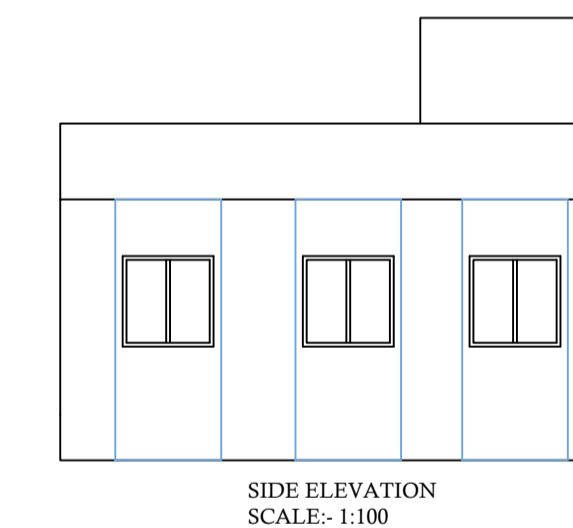
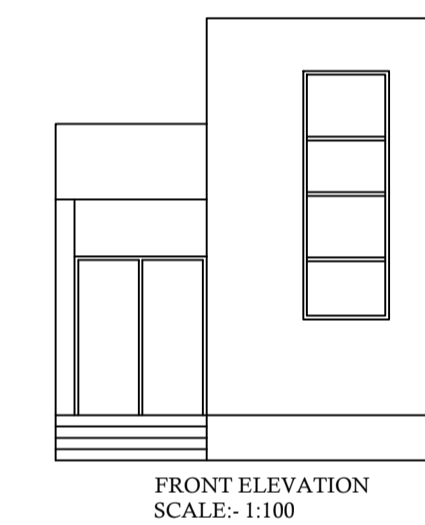
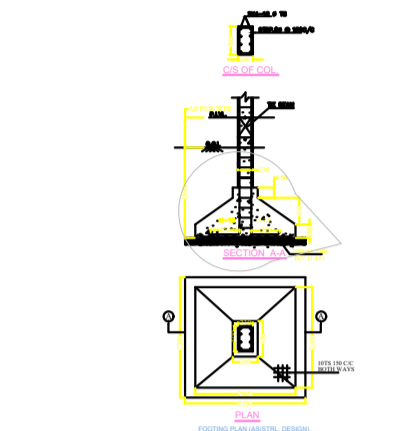

COLOR INDEX	
PLOT BOUNDARY	Black
ABUTTING ROAD	Green
PROPOSED CONSTRUCTION	Red
COMMON PLOT	Yellow
ROAD WIDENING AREA	Blue
EXISTING (To be retained)	Light Blue
EXISTING (To be demolished)	White

Building :A (SMT REETA VERMA)

Floor Name	Total Built Up Area (Sq.mt.)	Deductions (Area in Sq.mt.)	Proposed FAR Area (Sq.mt.)	Total FAR Area (Sq.mt.)	Total Consumed Additional FAR Area (Sq.mt.)	Trnmt (No.)
Ground Floor	39.06	0.90	38.16	38.16	38.16	01
Terrace Floor	0.00	0.00	0.00	0.00	0.00	00
Total :	39.06	0.90	38.16	38.16	38.16	01
Total Number of Same Buildings	1					
Total :	39.06	0.90	38.16	38.16	38.16	01

SCHEDULE OF DOOR:

BUILDING NAME	NAME	LENGTH	HEIGHT	NOS
A (SMT REETA VERMA)	D2	0.75	2.10	01
A (SMT REETA VERMA)	D1	0.90	2.13	01
A (SMT REETA VERMA)	D	1.00	2.13	01
A (SMT REETA VERMA)	G	1.75	2.10	01

SCHEDULE OF WINDOW/VENTILATION:

BUILDING NAME	NAME	LENGTH	HEIGHT	NOS
A (SMT REETA VERMA)	V	0.60	0.60	01
A (SMT REETA VERMA)	W1	1.20	1.20	04
A (SMT REETA VERMA)	W	1.50	1.20	01

UnitBUA Table for Building :A (SMT REETA VERMA)

FLOOR	Name	UnitBUA Type	UnitBUA Area	Carpet Area	No. of Rooms	No. of Tenement
GROUND FLOOR PLAN	SPLIT FLAT A	FLAT	28.14	26.22	5	1
Total:	-	-	28.14	26.22	5	1

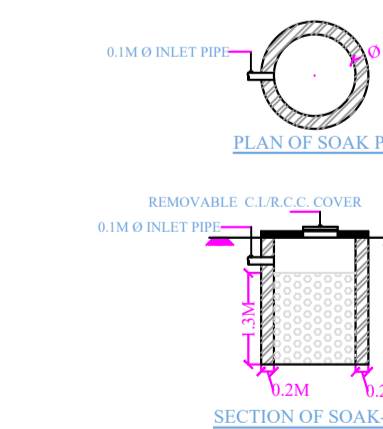

LTP NAME AND SIGNATURE	STRUCTURAL ENG'S NAME AND SIGNATURE	BUILDER NAME AND SIGNATURE	DIGITAL SIGNATURE
KUNAL GUIN CNP/ENG/0006/2017			