

GROUND FLOOR PLAN (Proposed) SCALE 1:100

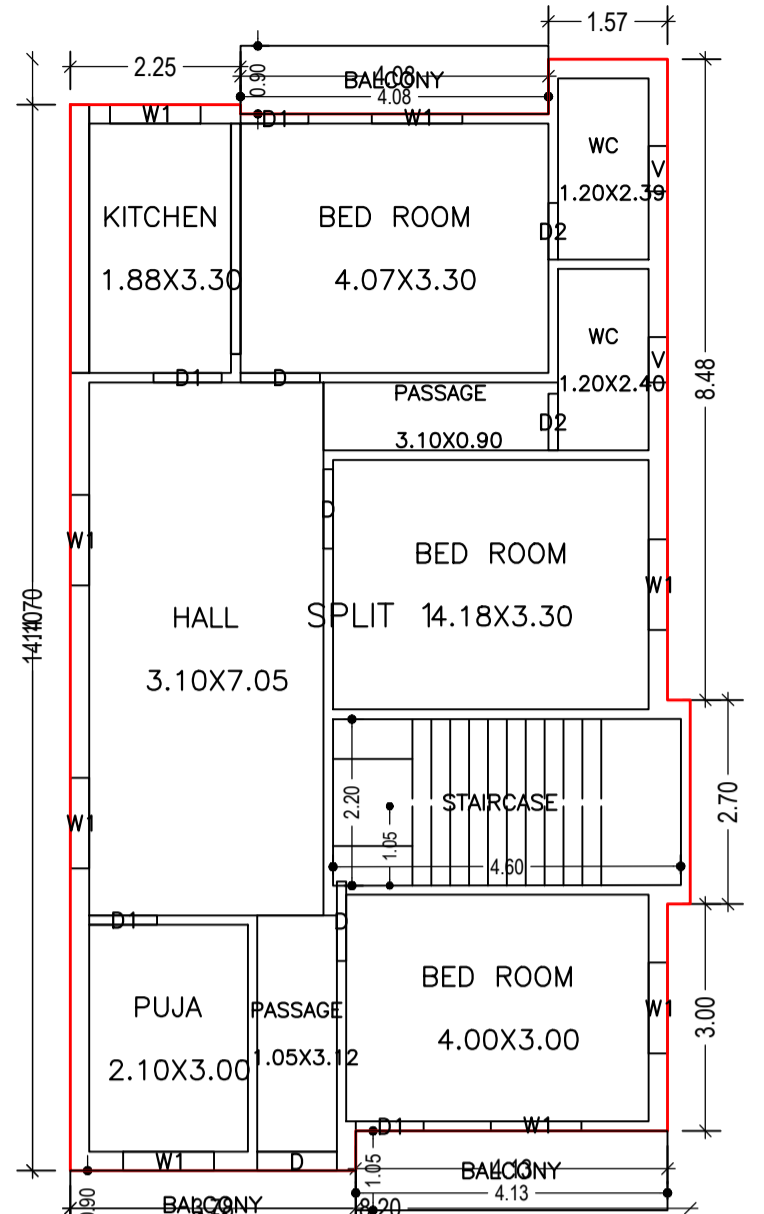

TYPICAL - 1 & 2 FLOOR PLAN (Proposed) SCALE 1:100

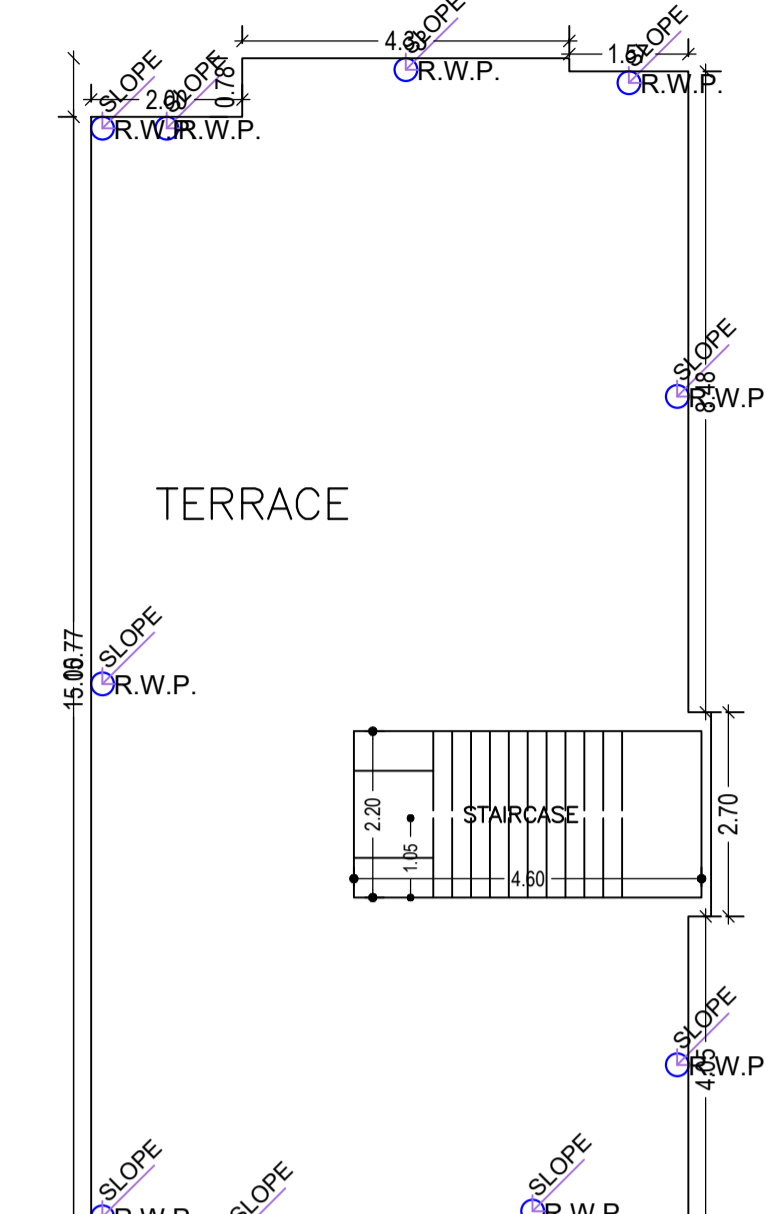

TERRACE FLOOR PLAN (SCALE 1:100)

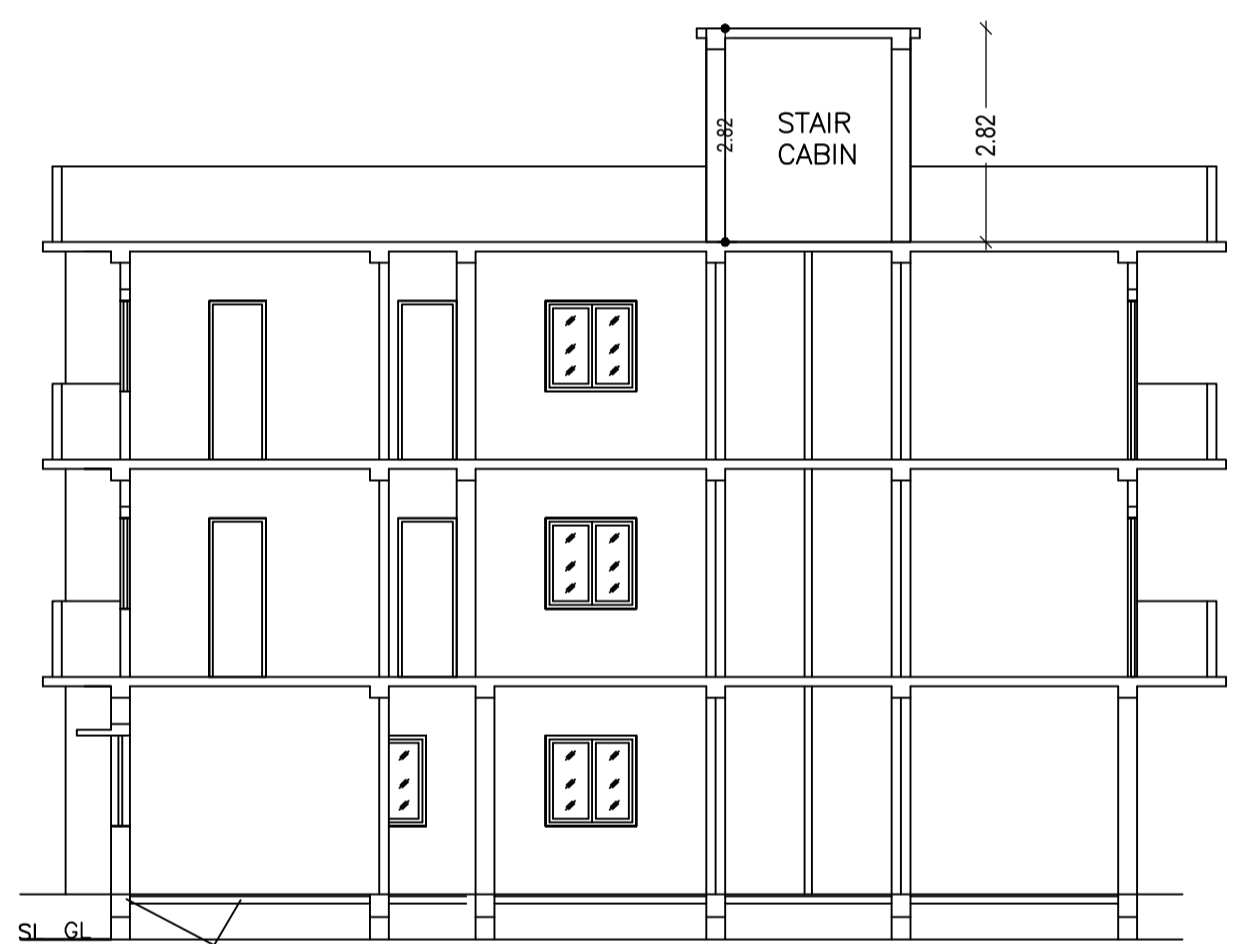

SECTION-XX SCALE: 1:100

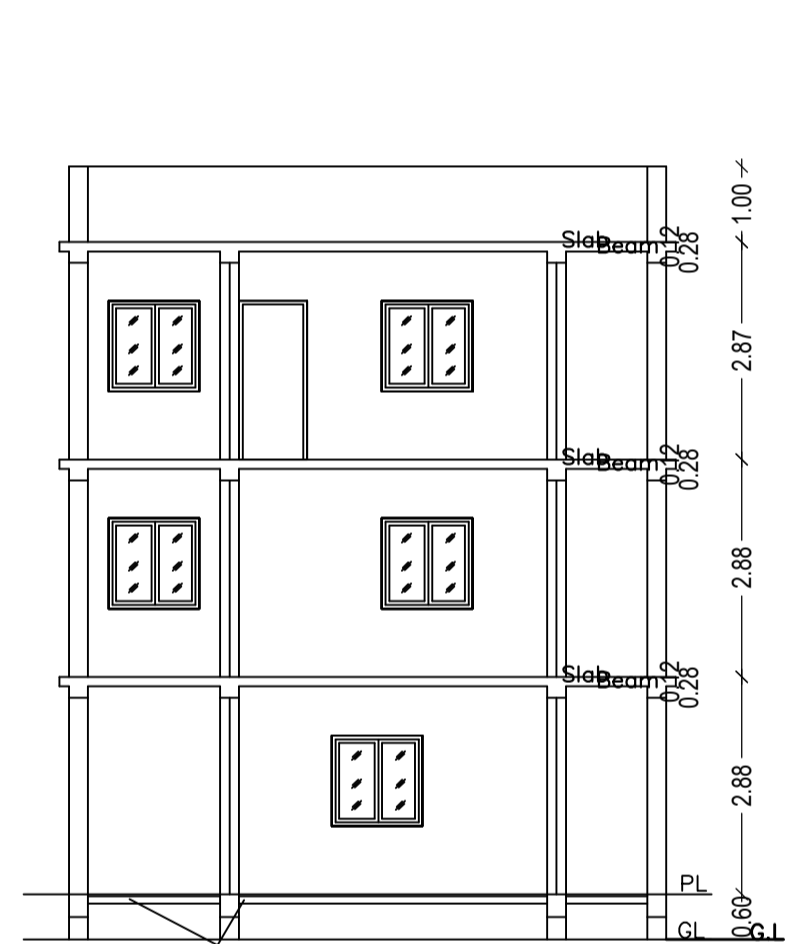

SECTION-YY SCALE: 1:100

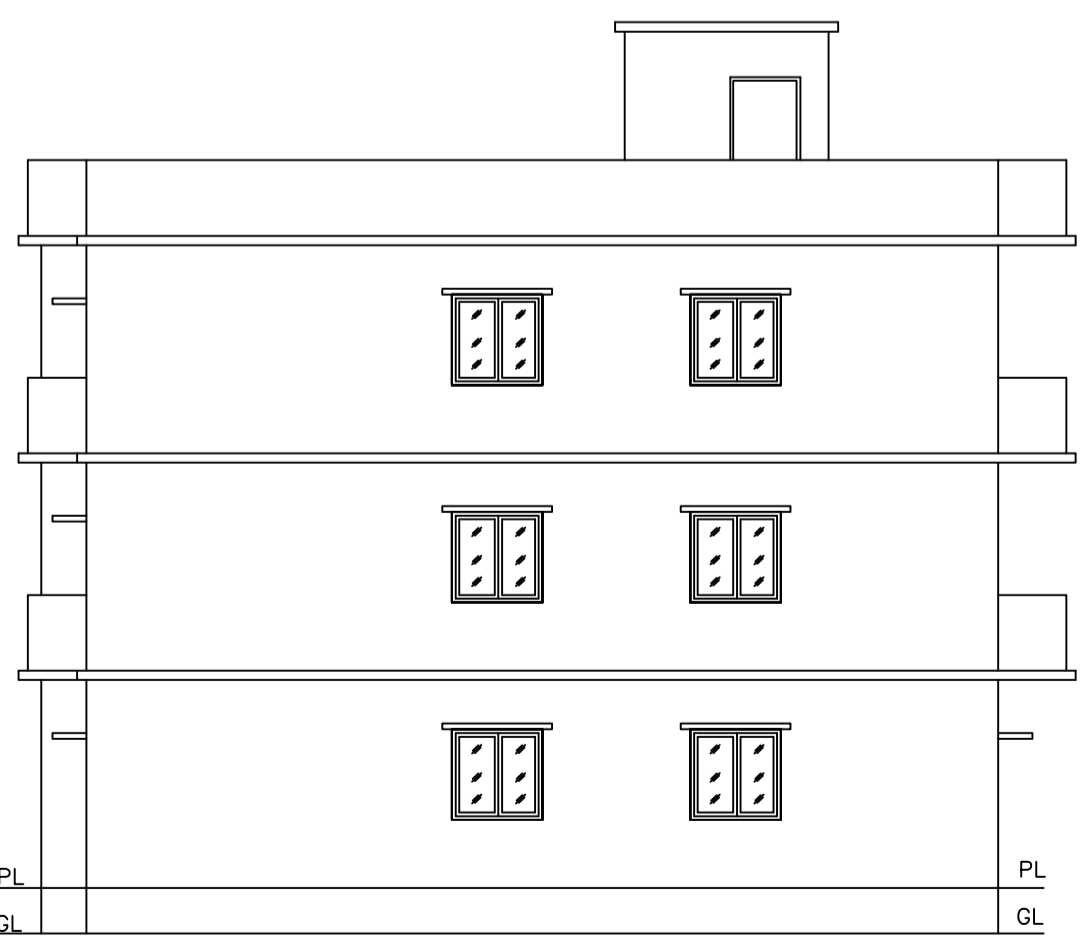

SIDE ELEVATIO SCALE- 1:100

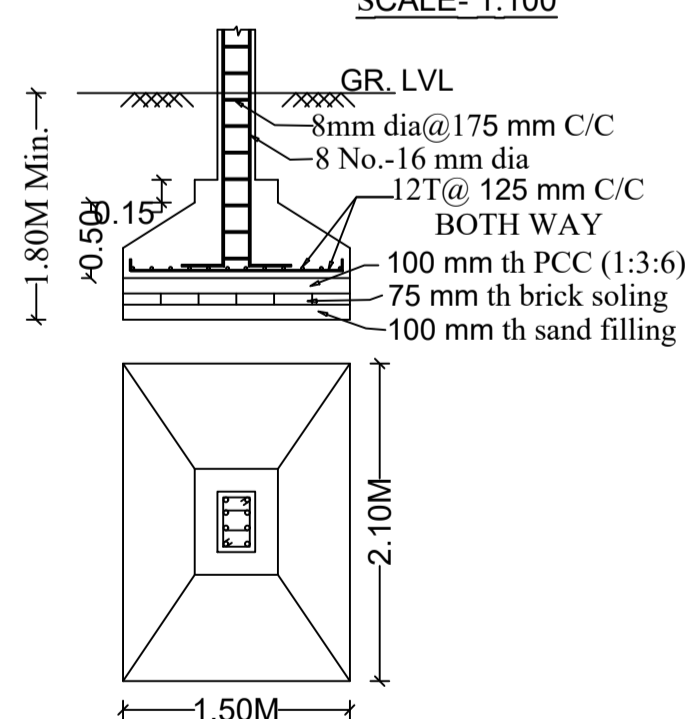

Column size-0.25M x0.40M FOUNDATION SCALE = 1:50

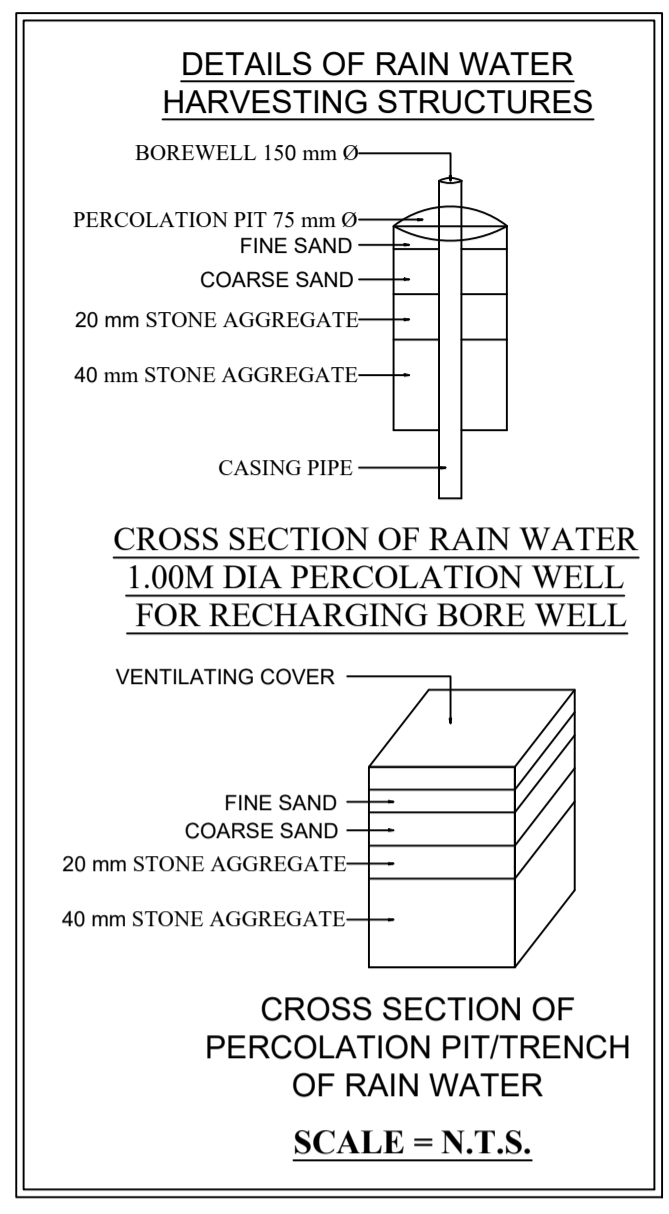

DETAILS OF RAIN WATER HARVESTING STRUCTURES

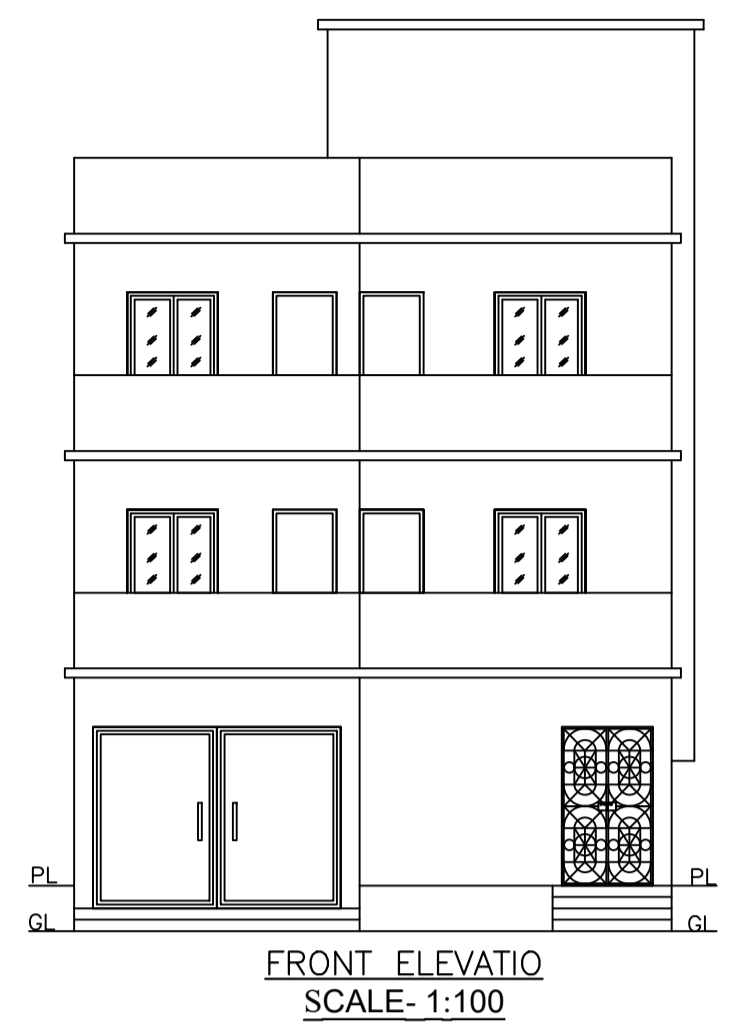

FRONT ELEVATIO SCALE- 1:100

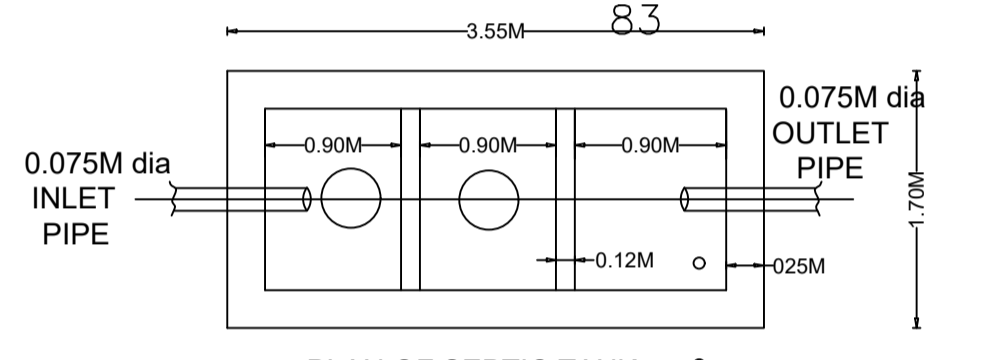

PLAN OF SEPTIC TANK

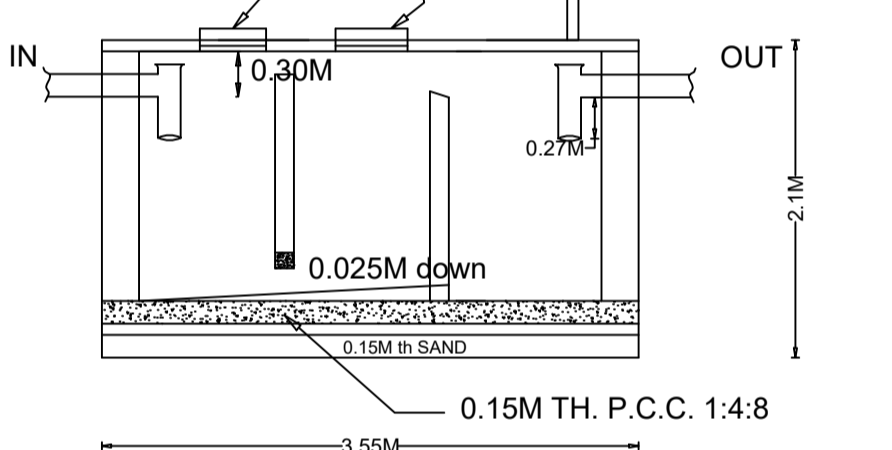

DETAIL OF SEPTIC TANK SCALE= 1:50

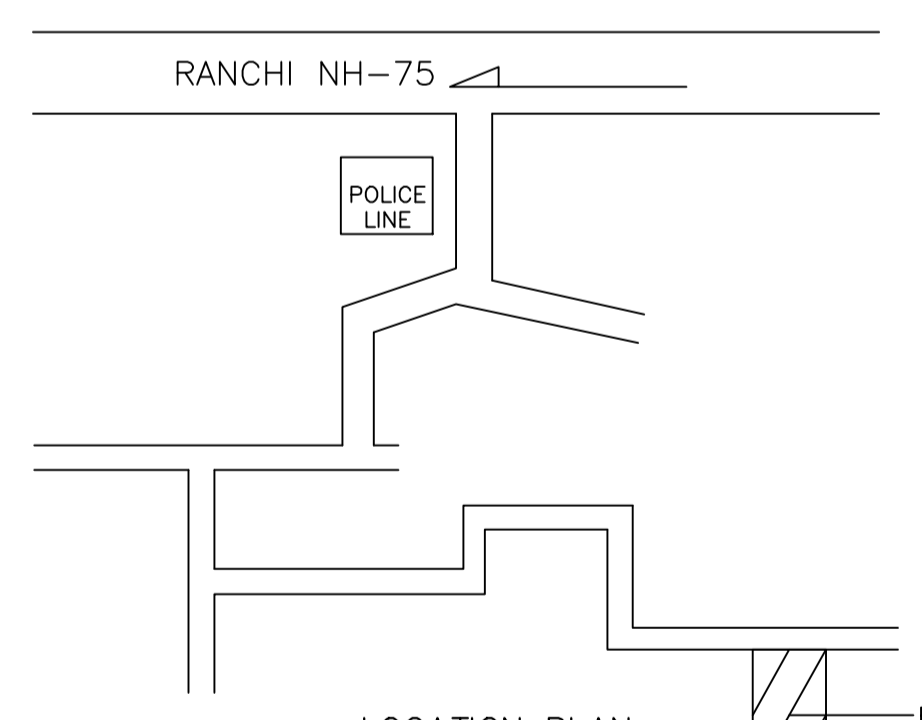

LOCATION PLAN SCALE: Not to scale

Proposal Basic Information

Proposal File No.	CNP/EP/022/W/14/2021
Owner Name	MR.MUKESH KUMAR GUPTA
Khata No	35
Plot No	61
Village Name	Nimdihi
Use	Residential
SubUse	Bungalow/ Dwelling / Non Apartment

AREA STATEMENT	VERSION NO.: 1.0.60	
CHAIKASA NAGAR	VERSION DATE: 16/10/2020	
PARISHAD		
PROJECT DETAIL:		
Region: JHARKHAND URBAN	Plot Use: Residential	
District: WEST SINGHBHUM	Plot SubUse: Bungalow/ Dwelling / Non Apartment	
Authority: CHAIKASA NAGAR	PlotNearby/ReligiousStructure: NA	
PARISHAD		
Inward No: CNP/EP/022/W/14/2021	Plot/SubPlot No: 61	
Application Type: General Proposal	North: Road Width - 6.20	
Project Type: Building Permission	South: Plot No. - NIJ	
Nature of Development: New	East: Plot No. - 25' WIDE RASTA	
Location of Development Area: Old Area	West: Plot No. - NIJ	
AREA DETAILS:		
AREA OF PLOT (Minimum)	(A)	SQ.MT. 186.17
NET AREA OF PLOT(Gross Plot Area - Deduction from Gross Plot area)	(A-Deductions)	186.17
Deduction for Balance Plot Area(from Gross Plot Area)		
Common Plot		27.45
Total		27.45
BALANCE AREA OF PLOT(Net Plot Area - Recreational/Amenity spaces)	(A-Deductions)	158.72
PLOT AREA FOR COVERAGE(Net Plot Area)	(A-Deductions)	186.17
Plot Area for FAR (Net Plot Area + Road/Widening Area)	(A-Deductions)	186.17
COVERAGE CHECK		
Permissible Coverage area ( 70.00 % )		130.32
Proposed Coverage Area ( 59.18 % )		110.18
Total Prop. Coverage Area ( 59.18 % )		110.18
Balance coverage area ( 10.82 % )		20.14
FAR CHECK		
Perm. FAR Area ( 2.00 )		372.34
Total Perm. FAR area		372.34
Residential FAR		308.08
Proposed FAR Area		308.08
Total Proposed FAR Area		308.08
Consumed FAR (Factor)		1.65
Balance FAR Area		64.26
BUILT UP AREA CHECK		
Total Proposed BuiltUp Area		353.94
ARCHITECT (Regd)	SAQUIB JAWED	
ENGINEER (Regd)		
SUPERVISOR (Regd)		
OWNER (Regd)	MR.MUKESH KUMAR GUPTA	
DEVELOPMENT AUTHORITY		LOCAL BODY

Building :A (RESIDENTIAL)

Floor Name	Total Built Up Area (Sq.mt.)	Deductions (Area in Sq.mt.)	Proposed FAR Area (Sq.mt.)	Total FAR Area (Sq.mt.)	Total Consumed Additional FAR Area (Sq.mt.)	Tnmt (No.)
Ground Floor	110.18	0.00	34.46	75.72	75.72	01
First Floor	121.88	5.70	0.00	116.18	116.18	00
Second Floor	121.88	5.70	0.00	116.18	116.18	00
Terrace Floor	0.00	0.00	0.00	0.00	0.00	00
Total :	353.94	11.40	34.46	308.08	308.08	01
Total Number of Same Buildings	1					
Total :	353.94	11.40	34.46	308.08	308.08	01

Buildingwise Floor FAR Details

Floor Name	Building Name		Total	
	Proposed Built Up Area (Sq.mt.)	Proposed FAR Area (Sq.mt.)	Total Proposed Built Up Area (Sq.mt.)	Total FAR Area (Sq.mt.)
Ground Floor	110.18	75.72	110.18	75.72
First Floor	121.88	116.18	121.88	116.18
Second Floor	121.88	116.18	121.88	116.18
Terrace Floor	0.00	0.00	0.00	0.00
Total :	353.94	308.08	353.94	308.08

SCHEDULE OF DOOR:

BUILDING NAME	NAME	LENGTH	HEIGHT	NOS
A (RESIDENTIAL)	D2	0.75	2.10	06
A (RESIDENTIAL)	D1	0.90	2.10	09
A (RESIDENTIAL)	D	1.05	2.10	11

SCHEDULE OF WINDOW/VENTILATION:

BUILDING NAME	NAME	LENGTH	HEIGHT	NOS
A (RESIDENTIAL)	V	0.60	1.20	06
A (RESIDENTIAL)	W1	1.20	1.20	20

UnitBUA Table for Building :A (RESIDENTIAL)

FLOOR	Name	UnitBUA Type	UnitBUA Area	Carpet Area	No. of Rooms	No. of Tenement
GROUND FLOOR PLAN	SPLIT 1	FLAT	236.43	235.29	7	1
TYPICAL - 1 & 2 FLOOR PLAN	SPLIT 1	FLAT	0.00	0.00	10	0
Total:	-	-	236.43	235.29	27	1

FAR & Tenement Details (Table 4c-1)

Building	No. of Same Bldg	Total Built Up Area (Sq.mt.)	Deductions (Area in Sq.mt.)		Proposed FAR Area (Sq.mt.)	Total FAR Area (Sq.mt.)	Total Consumed Additional FAR Area (Sq.mt.)	Tnmt (No.)
			Balcony	Parking				
A (RESIDENTIAL)	1	353.94	11.40	34.46	308.08	308.08	308.08	01
Grand Total :	1	353.94	11.40	34.46	308.08	308.08	308.08	01

COLOR INDEX

PLOT BOUNDARY	[Red Line]
ADJUTING ROAD	[Green Line]
PROPOSED CONSTRUCTION	[Blue Line]
COMMON PLOT	[Yellow Line]
ROAD WIDENING AREA	[Orange Line]
EXISTING (To be retained)	[Light Blue Line]
EXISTING (To be demolished)	[Light Green Line]

LTP NAME AND SIGNATURE	SAQUIB JAWED CNP/ENG/0007/2021
STRUCTURAL ENG'S NAME AND SIGNATURE	
BUILDER NAME AND SIGNATURE	
DIGITAL SIGNATURE	

Building USE/SUBUSE Details

Building Name	Building Use	Building SubUse	Building Structure
A (RESIDENTIAL)	Residential	Bungalow/ Dwelling / Non Apartment	Non-Highrise

Balcony Calculations Table

FLOOR	SIZE	AREA	TOTAL AREA
TYPICAL - 1 & 2 FLOOR PLAN	0.90 X 3.78 X 1 X 2	6.80	22.80
	1.05 X 4.13 X 1 X 2	8.66	
	0.90 X 4.08 X 1 X 2	7.34	
Total			22.80