

Proposal Basic Information

Proposal File No.	CNP/BP/0025/W19/2021
Owner Name	SIMPY BUDHIA
Khata No	135
Plot No	301
Village Name	Tungri
Use	Residential
SubUse	Bungalow/ Dwelling / Non Apartment

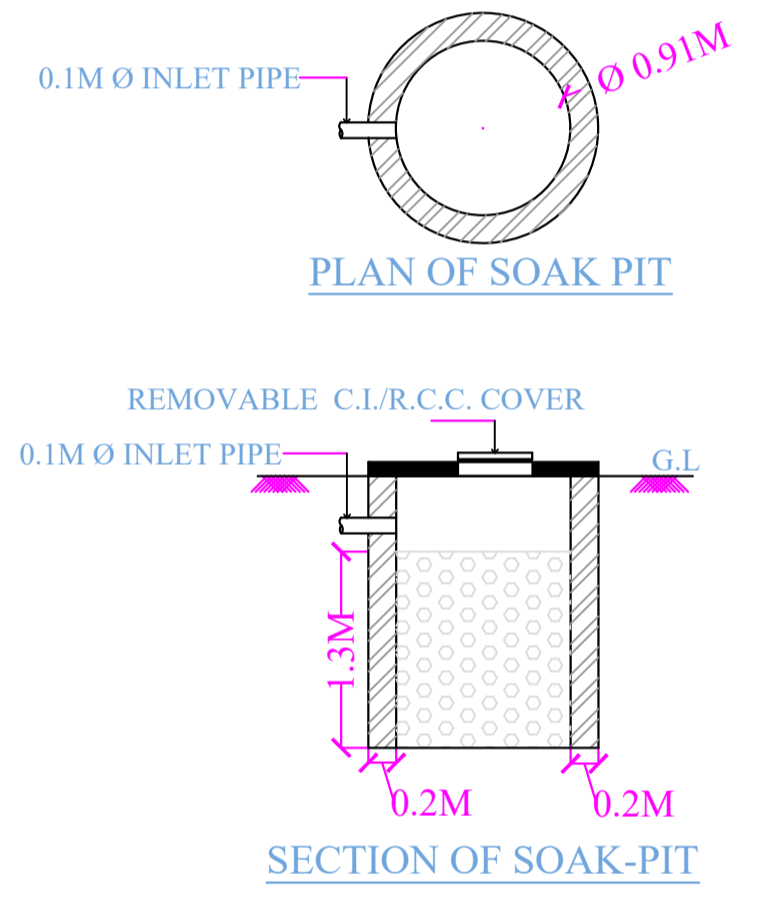
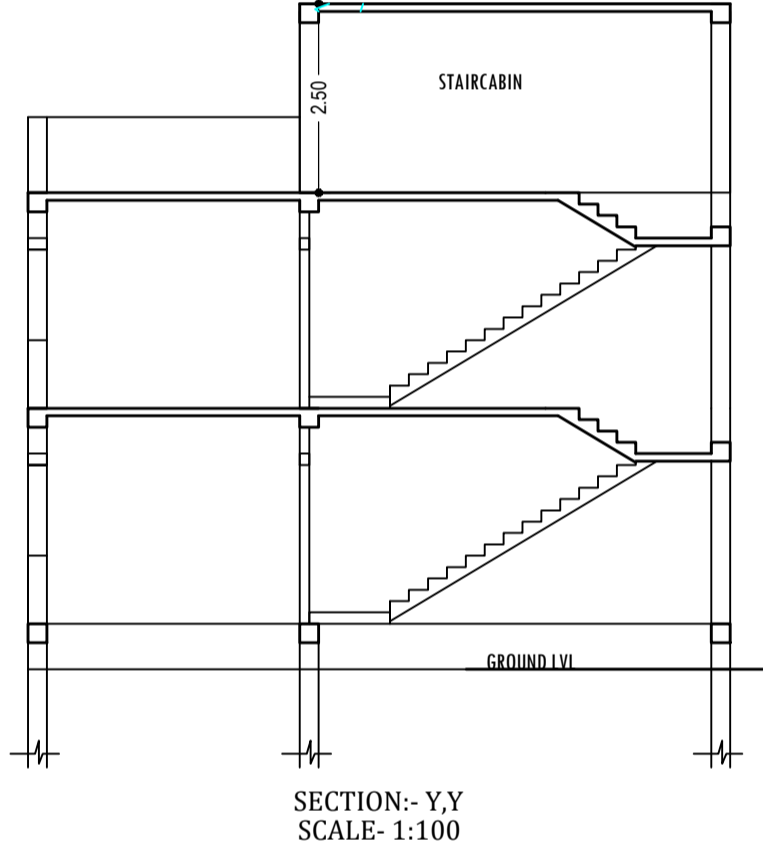
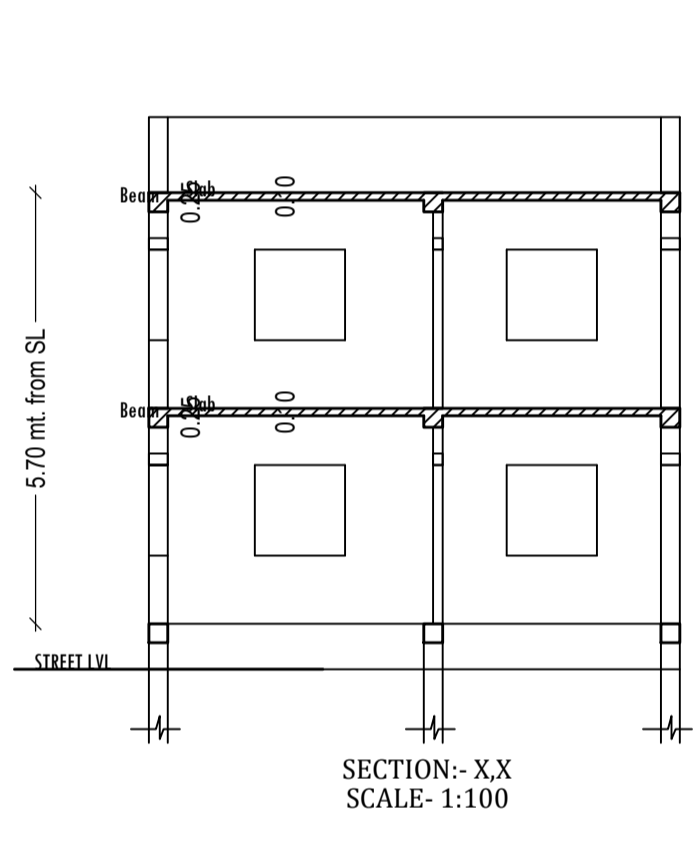
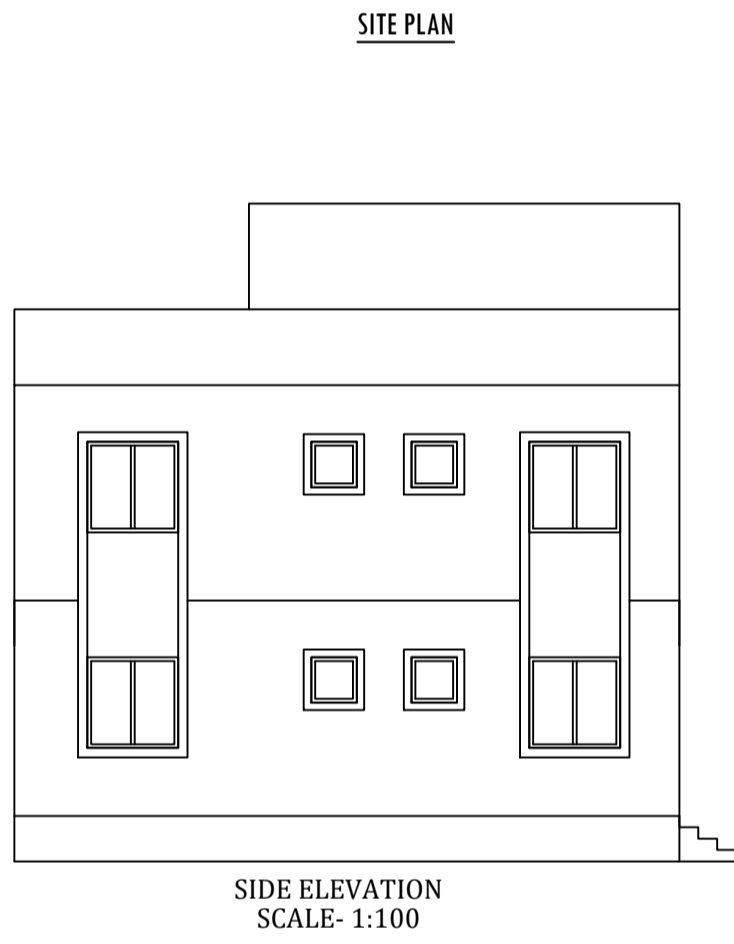
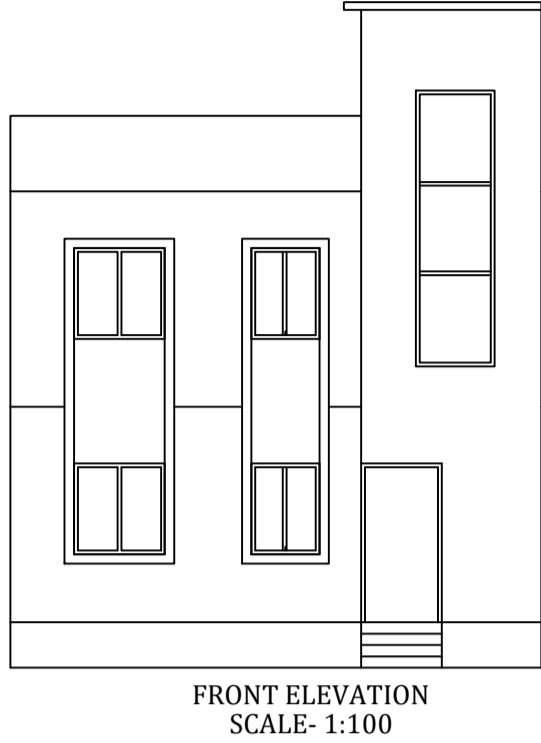
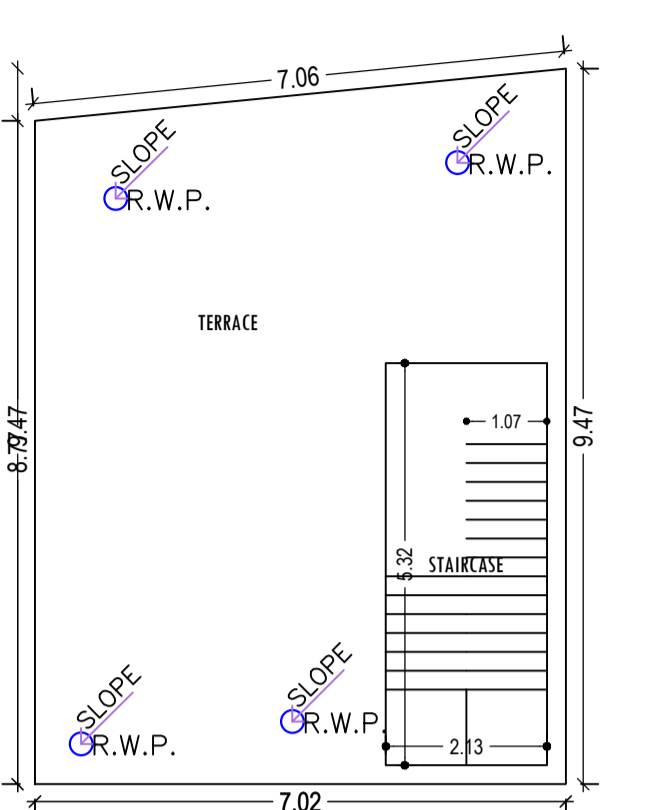
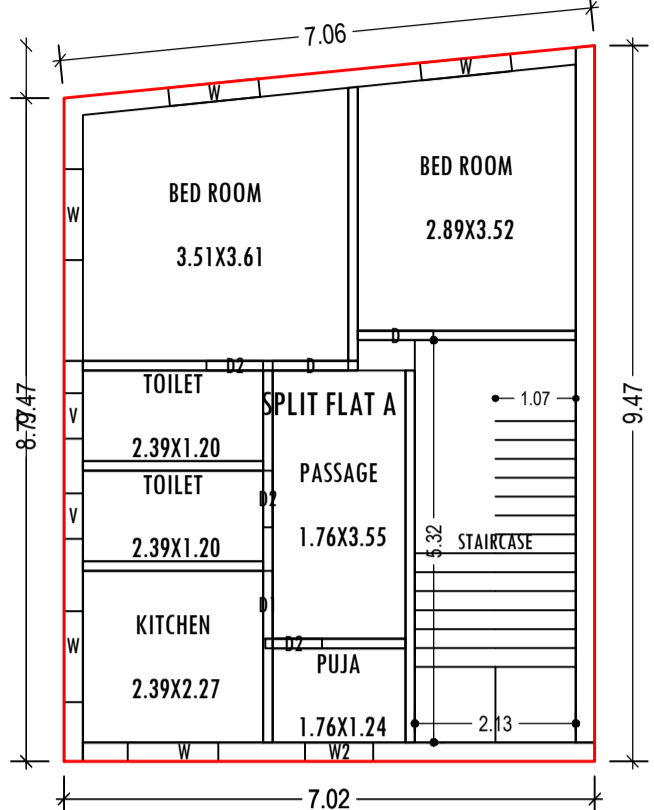
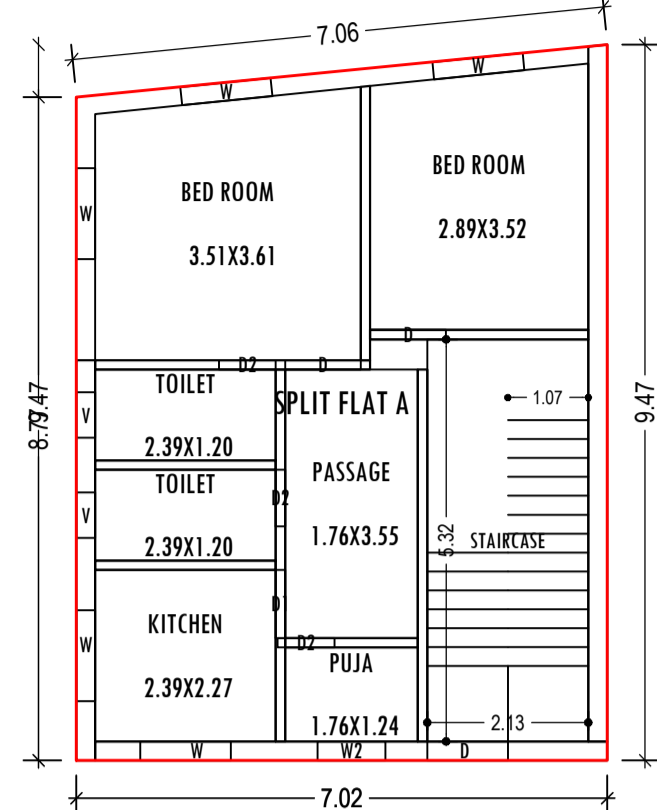
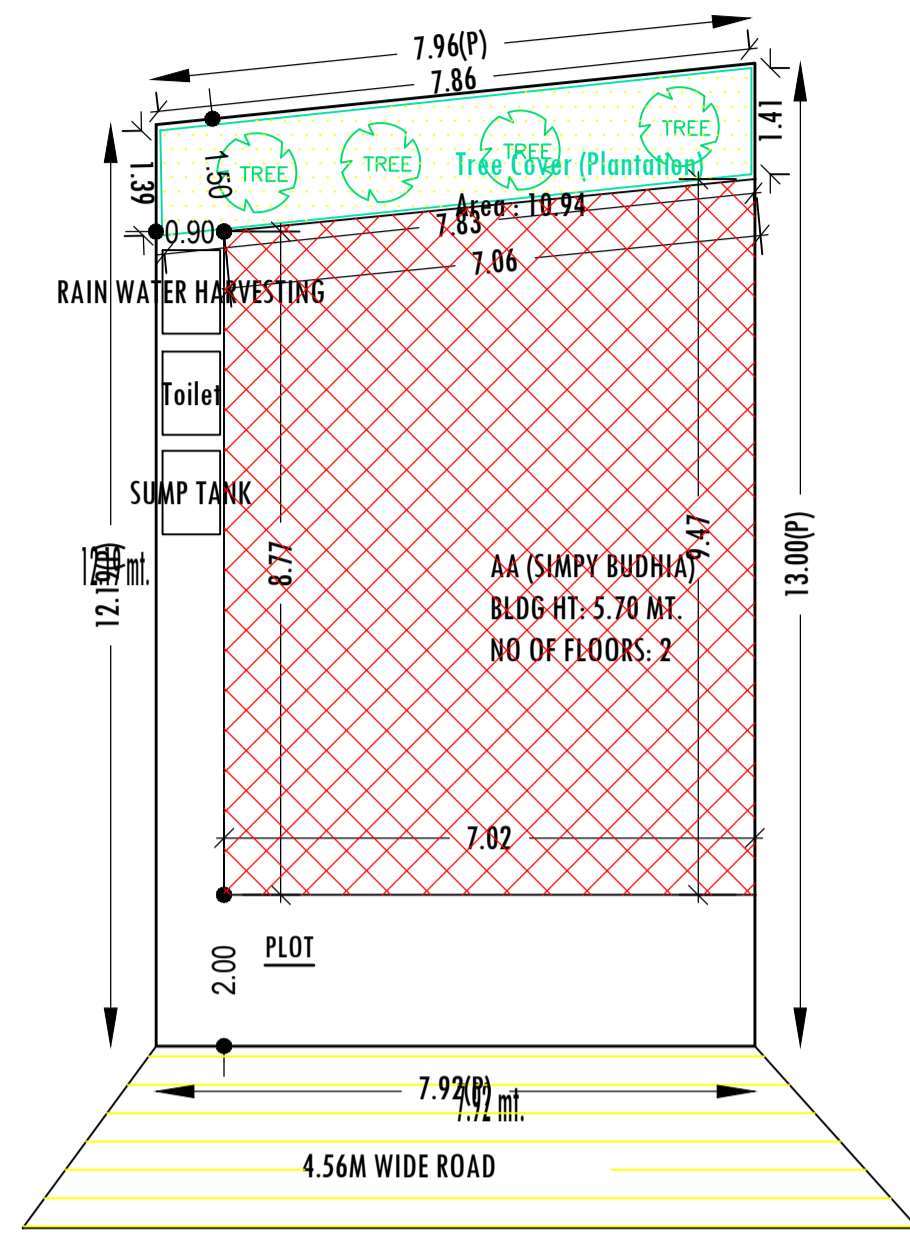

AREA STATEMENT	VERSION NO. : 1.0.56
CHAIBASA NAGAR	VERSION DATE: 16/10/2020
PARISHAD	
PROJECT DETAIL:	
Region: JHARKHAND URBAN LOCAL BODIES	Plot Use: Residential
District: WEST SINGBHUM	Plot SubUse: Bungalow/ Dwelling / Non Apartment
Authority: CHAIBASA NAGAR PARISHAD	Plot/Nearby/ReligiousStructure: NA
Inward No: CNP/BP/0025/W19/2021	Plot/SubPlot No: 301
Application Type: General Proposal	North: Plot No. - 3-6' GALLI
Project Type: Building Permission	South: Plot No. - AGARWAL
Nature of Development: New	East: Plot No. - AGARWAL
Location of Development Area: Old Area	West: Plot No. - RAJKUMAR AND SURESH KUMAR BUDHIA
AREA DETAILS:	SQ.MT.
AREA OF PLOT (Minimum)	99.77
NET AREA OF PLOT(Gross Plot Area - Deduction from Gross Plot area)	99.77
Deduction for Balance Plot Area(from Gross Plot Area)	
Total	10.94
BALANCE AREA OF PLOT(Net Plot Area - Recreational/Amenity space)	88.83
PLOT AREA FOR COVERAGE(Net Plot Area)	99.77
Plot Area for FAR (Net Plot Area + RoadWidening Area)	99.77
COVERAGE CHECK	
Permissible Coverage area (70.00 %)	69.84
Proposed Coverage Area (64.19 %)	64.04
Total Prop. Coverage Area (64.19 %)	64.04
Balance coverage area (5.81 %)	5.80
FAR CHECK	
Perm. FAR Area (1.50)	149.65
Total Perm. FAR area	149.65
Residential FAR	128.07
Proposed FAR Area	128.07
Total Proposed FAR Area	128.07
Consumed FAR (Factor)	1.28
Balance FAR Area	21.58
BUILT UP AREA CHECK	
Total Proposed BuiltUp Area	128.08
ARCHITECT (Regd)	KUNAL GUIN
ENGINEER (Regd)	
SUPERVISOR (Regd)	
OWNER (Regd)	SIMPY BUDHIA
DEVELOPMENT AUTHORITY	LOCAL BODY

Floor Name	Total Built Up Area (Sq.mt.)	Proposed FAR Area (Sq.mt.) Resi.	Total FAR Area (Sq.mt.)	Total Consumed Additional FAR Area (Sq.mt.)	Tnmt (No.)
Ground Floor	64.04	64.04	64.04	64.04	01
First Floor	64.04	64.04	64.04	64.04	00
Terrace Floor	0.00	0.00	0.00	0.00	00
Total :	128.08	128.08	128.08	128.08	01
Total Number of Same Buildings	1				
Total :	128.08	128.08	128.08	128.08	01

Floor Name	Building Name		Total	
	Proposed Built Up Area (Sq.mt.)	Proposed FAR Area (Sq.mt.)	Total Proposed Built Up Area (Sq.mt.)	Total FAR Area (Sq.mt.)
Ground Floor	64.04	64.04	64.04	64.04
First Floor	64.04	64.04	64.04	64.04
Terrace Floor	0.00	0.00	0.00	0.00
Total :	128.08	128.08	128.08	128.08

SCHEDULE OF DOOR:

BUILDING NAME	NAME	LENGTH	HEIGHT	NOS
AA (SIMPY BUDHIA)	D2	0.75	2.13	06
AA (SIMPY BUDHIA)	D1	0.90	2.13	02
AA (SIMPY BUDHIA)	D	1.00	2.13	04

SCHEDULE OF WINDOW/VENTILATION:

BUILDING NAME	NAME	LENGTH	HEIGHT	NOS
AA (SIMPY BUDHIA)	V	0.60	0.60	04
AA (SIMPY BUDHIA)	W2	0.90	1.20	02
AA (SIMPY BUDHIA)	W	1.20	1.20	10

Building USE/SUBUSE Details

Building Name	Building Use	Building SubUse	Building Structure
AA (SIMPY BUDHIA)	Residential	Bungalow/ Dwelling / Non Apartment	Non-Highrise

FAR & Tenement Details (Table 4c-1)

Building	No. of Same Bldg	Total Built Up Area (Sq.mt.)	Proposed FAR Area (Sq.mt.) Resi.	Total FAR Area (Sq.mt.)	Total Consumed Additional FAR Area (Sq.mt.)	Tnmt (No.)
AA (SIMPY BUDHIA)	1	128.08	128.08	128.08	128.08	01
Grand Total :	1	128.08	128.08	128.08	128.08	01

UnitBUA Table for Building :AA (SIMPY BUDHIA)

FLOOR	Name	UnitBUA Type	UnitBUA Area	Carpet Area	No. of Rooms	No. of Tenement
GROUND FLOOR PLAN	SPLIT FLAT A	FLAT	89.93	83.30	7	1
FIRST FLOOR PLAN	SPLIT FLAT A	FLAT	0.00	0.00	7	0
Total:	-	-	89.93	83.30	14	1

COLOR INDEX

PLOT BOUNDARY	Black
ABUTTING ROAD	Green
PROPOSED CONSTRUCTION	Red
COMMON PLOT	Yellow
ROAD WIDENING AREA	Blue
EXISTING (To be retained)	Orange
EXISTING (To be demolished)	Grey

LTP NAME AND SIGNATURE	STRUCTURAL ENG'S NAME AND SIGNATURE	BUILDER NAME AND SIGNATURE	DIGITAL SIGNATURE
KUNAL GUIN CNP/ENG/0006/2017			