

SITE PLAN
SCALE:- 1:100

SITE PLAN

FAR & Tenement Details (Table 4c-1)

Building	No. of Same Bldg	Total Built Up Area (Sq.mt.)	Deductions (Area in Sq.mt.)		Proposed FAR Area (Sq.mt.)	Add Area In FAR (Sq.mt.)	Total FAR Area (Sq.mt.)	Total Consumed Additional FAR Area (Sq.mt.)	Tnmt (No.)
			Lift	Parking					
A (SHAKUNTALA DEVI SHAKUNTALA DEVI AGARWAL)	1	540.38	10.68	127.76	385.23	13.15	401.94	401.94	03
Grand Total	1	540.38	10.68	127.76	385.23	13.15	401.94	401.94	03

Proposal Basic Information

Proposal File No.	CNP/BP/0024/W14/2021
Owner Name	SMT. SHAKUNTALA DEVI AGARWAL
Khata No	50
Plot No	76
Village Name	Bada Nimdih
Use	Residential
SubUse	Bungalow/ Dwelling / Non Apartment

Required Parking (Table 7a)

Building Name	Type	SubUse	Area (Sq.mt.)	Units		Car		Visitors Car		TwoWheeler	
				Reqd.	Prop.	Reqd./Unit	Prop.	Reqd./Unit	Prop.	Reqd./Unit	Prop.
A (SHAKUNTALA DEVI SHAKUNTALA DEVI AGARWAL)	Residential	Bungalow/ Dwelling / Non Apartment	> 0	1	3.00	1	3	-	-	-	-
			> 0	1	3.00	-	-	1	1	-	-
Total :			-	-	-	-	3	3	1	1	0

Parking Check (Table 7b)

Vehicle Type	Reqd.		Prop.	
	No.	Area	No.	Area
Car	-	-	3	37.50
Total Car	3	37.50	3	37.50
Visitor's Car Parking	-	-	1	12.50
Total Visitor Parking	1	12.50	1	12.50
TwoWheeler	-	-	6	12.00
Total TwoWheeler	-	-	6	12.00
Other Parking	-	-	-	96.76
Total		50.00		170.76

AREA STATEMENT CHAIBASA NAGAR PARISHAD	VERSION NO. : 1.0.56 VERSION DATE: 16/10/2020
PROJECT DETAIL:	
Region: JHARKHAND URBAN LOCAL BODIES	Plot Use: Residential
District: WEST SINGHBHUM	Plot SubUse: Bungalow/ Dwelling / Non Apartment
Authority: CHAIBASA NAGAR PARISHAD	PlotNearbyReligiousStructure: NA
Inward No: CNP/BP/0024/W14/2021	PlotSubPlot No: 76
Application Type: General Proposal	North: Road Width - 15 feet road
Project Type: Building Permission	South: Road Width - 25 feet road
Nature of Development: New	East: Plot No. - block no. 76/i on portion of plot no. 76
Location of Development Area: Old Area	West: Plot No. - block no. 76/i on portion of plot no. 76
AREA DETAILS:	SQ.MT.
AREA OF PLOT (Minimum)	(A) 241.43
NET AREA OF PLOT(Gross Plot Area - Deduction from Gross Plot area)	(A-Deductions) 241.43
Deduction for Balance Plot Area(from Gross Plot Area)	
Common Plot	25.99
Total	25.99
BALANCE AREA OF PLOT(Net Plot Area - Recreational/Amenity space)	(A-Deductions) 215.44
PLOT AREA FOR COVERAGE(Net Plot Area)	(A-Deductions) 241.43
Plot Area for FAR (Net Plot Area + RoadWidening Area)	(A-Deductions) 241.43
COVERAGE CHECK	
Permissible Coverage area (60.00 %)	144.86
Proposed Coverage Area (54.66 %)	131.96
Total Prop. Coverage Area (54.66 %)	131.96
Balance coverage area (5.34 %)	12.90
FAR CHECK	
Perm. FAR Area (2.00)	482.86
Total Perm. FAR area	482.86
Residential FAR	385.23
Proposed FAR Area	401.93
Total Proposed FAR Area	401.93
Consumed FAR (Factor)	1.66
Balance FAR Area	80.93
BUILT UP AREA CHECK	
Total Proposed BuiltUp Area	540.38
ARCHITECT (Regd)	KUNAL GUIN
ENGINEER (Regd)	
SUPERVISOR (Regd)	
OWNER (Regd)	SMT. SHAKUNTALA DEVI AGARWAL
DEVELOPMENT AUTHORITY	LOCAL BODY

COLOR INDEX	
PLOT BOUNDARY	Black
ABUTTING ROAD	Green
PROPOSED CONSTRUCTION	Red
COMMON PLOT	Yellow
ROAD WIDENING AREA	Blue
EXISTING (To be retained)	Light Blue
EXISTING (To be demolished)	Light Yellow

Buildingwise Floor FAR Details

Floor Name	Building Name A (SHAKUNTALA DEVI SHAKUNTALA DEVI AGARWAL)		Total	
	Proposed Built Up Area (Sq.mt.)	Proposed FAR Area (Sq.mt.)	Total Proposed Built Up Area (Sq.mt.)	Total FAR Area (Sq.mt.)
Ground Floor	144.47	16.71	144.47	16.71
First Floor	131.97	128.41	131.97	128.41
Second Floor	131.97	128.41	131.97	128.41
Third Floor	131.97	128.41	131.97	128.41
Terrace Floor	0.00	0.00	0.00	0.00
Total :	540.38	401.94	540.38	401.94

Building USE/SUBUSE Details

Building Name	Building Use	Building SubUse	Building Structure
A (SHAKUNTALA DEVI SHAKUNTALA DEVI AGARWAL)	Residential	Bungalow/ Dwelling / Non Apartment	Non-Highrise

LTP NAME AND SIGNATURE	STRUCTURAL ENG'S NAME AND SIGNATURE	BUILDER NAME AND SIGNATURE	DIGITAL SIGNATURE
KUNAL GUIN CNP/ENG/0006/2017			

Proposal Basic Information	
Proposal File No.	CNP/BP/0024/W14/2021
Owner Name	SMT. SHAKUNTALA DEVI AGARWAL
Khata No	50
Plot No	76
Village Name	Bada Nimdi
Use	Residential
SubUse	Bungalow/ Dwelling / Non Apartment

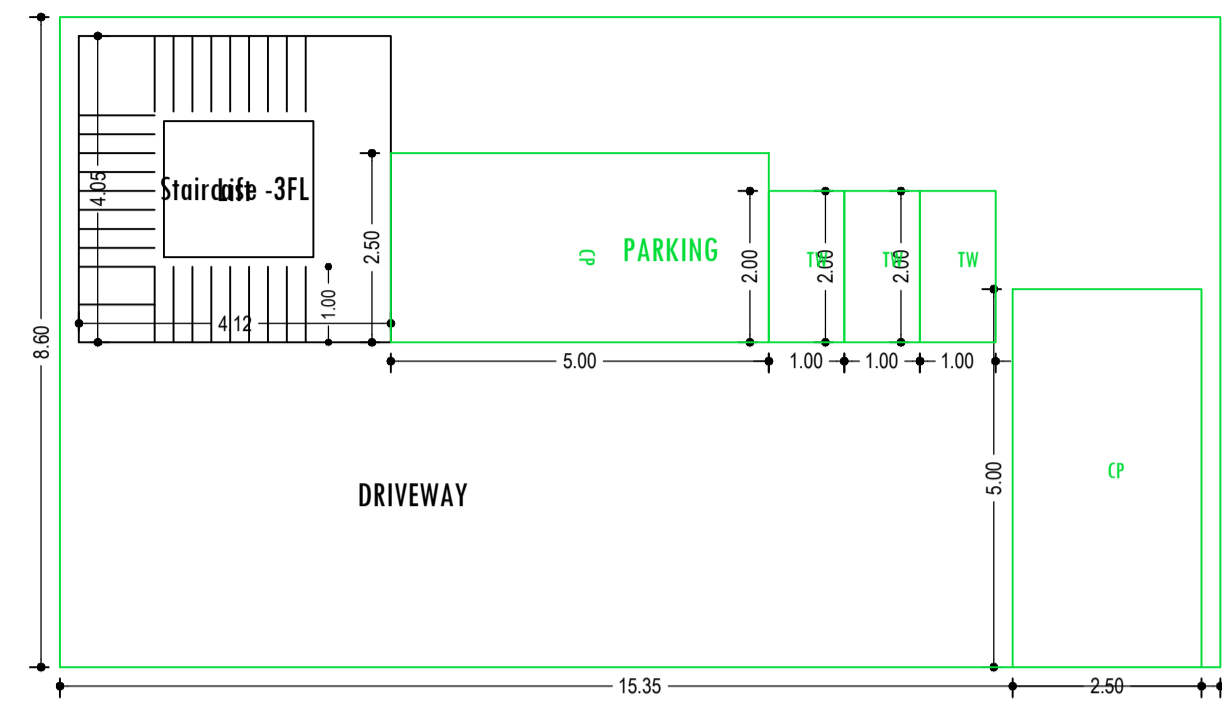

GROUND FLOOR PLAN (SCALE 1:100)

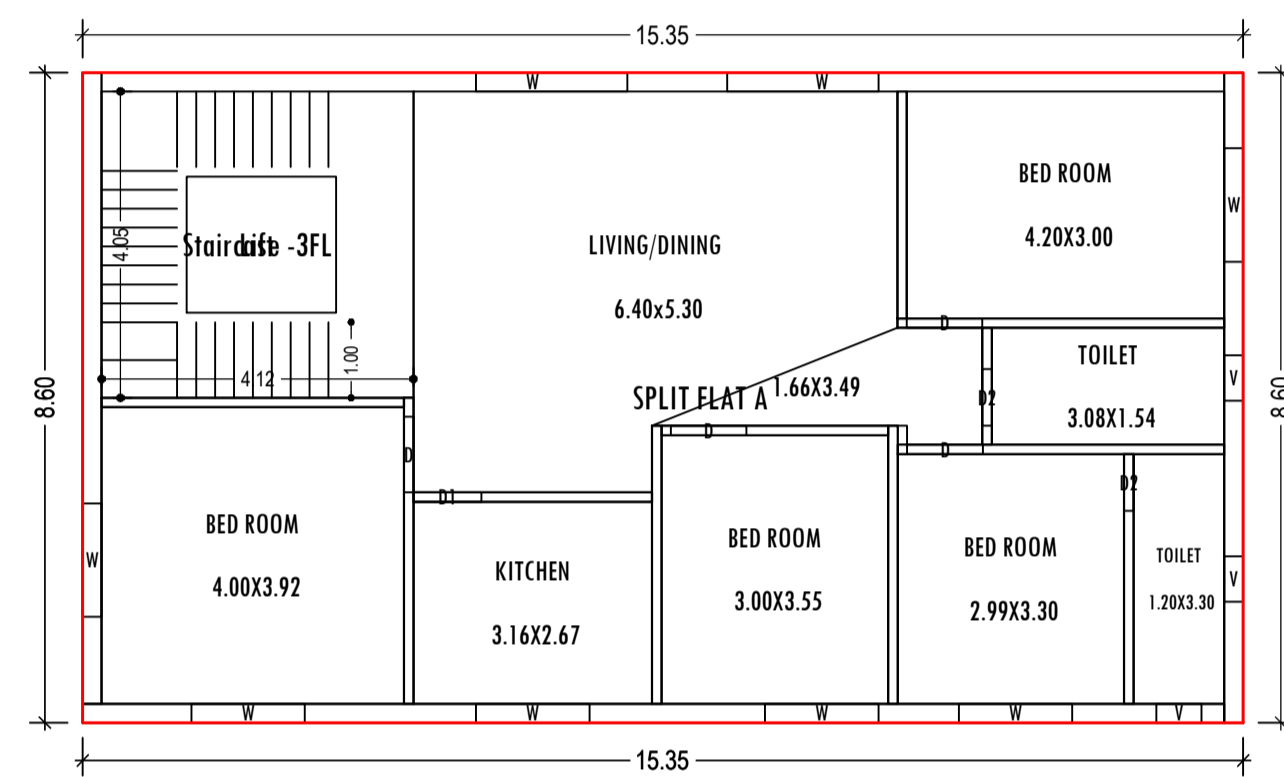

TYPICAL - 1, 2& 3 FLOOR PLAN (Proposed) (SCALE 1:100)

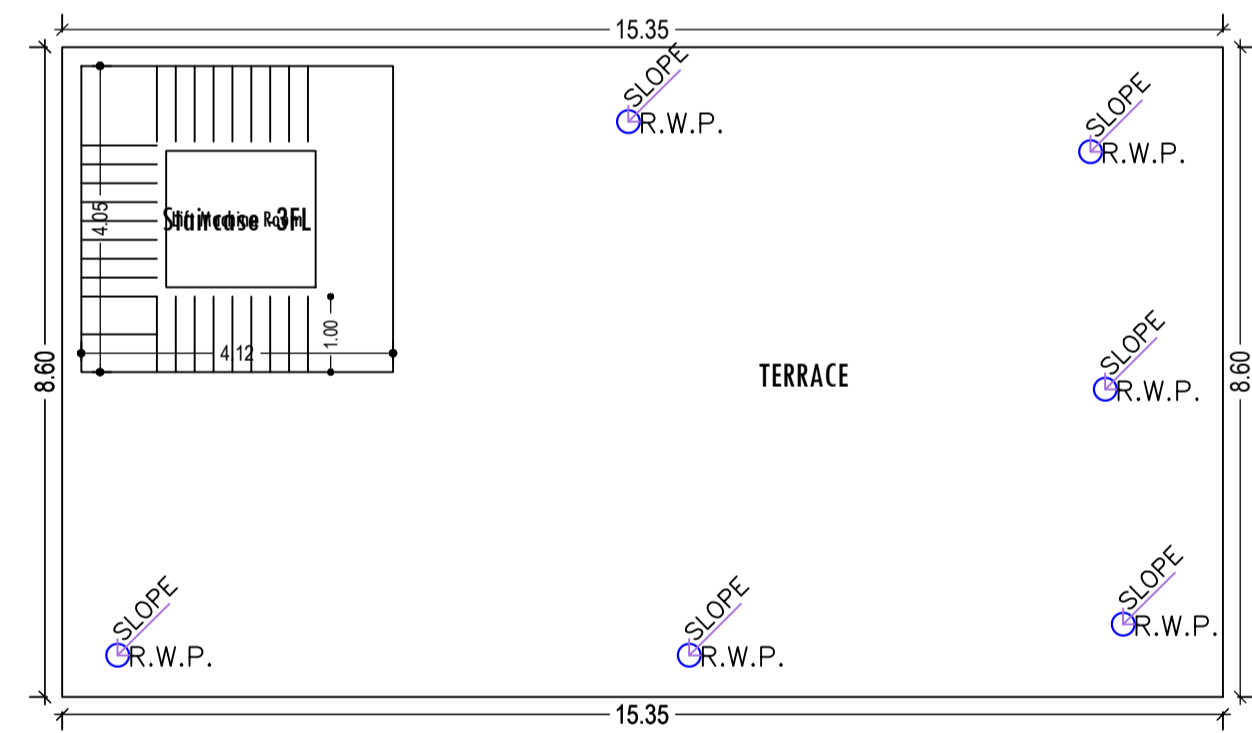

TERRACE FLOOR PLAN (SCALE 1:100)

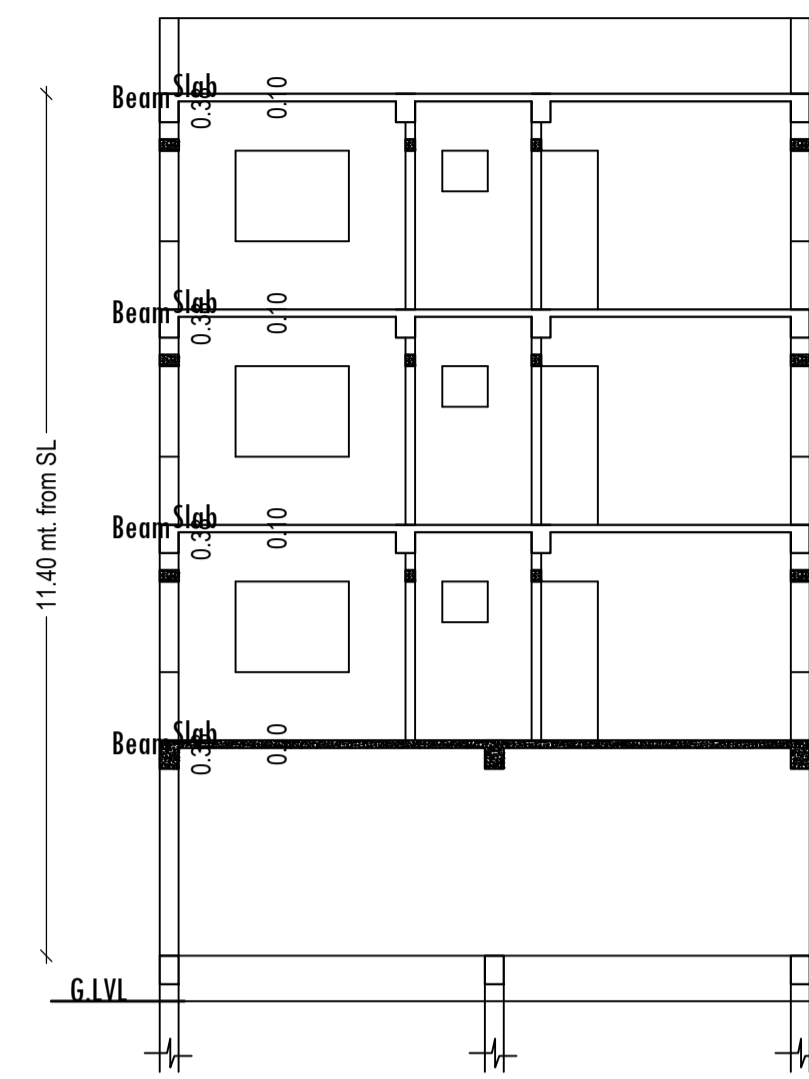

SECTION :- Y,Y SCALE:- 1:100

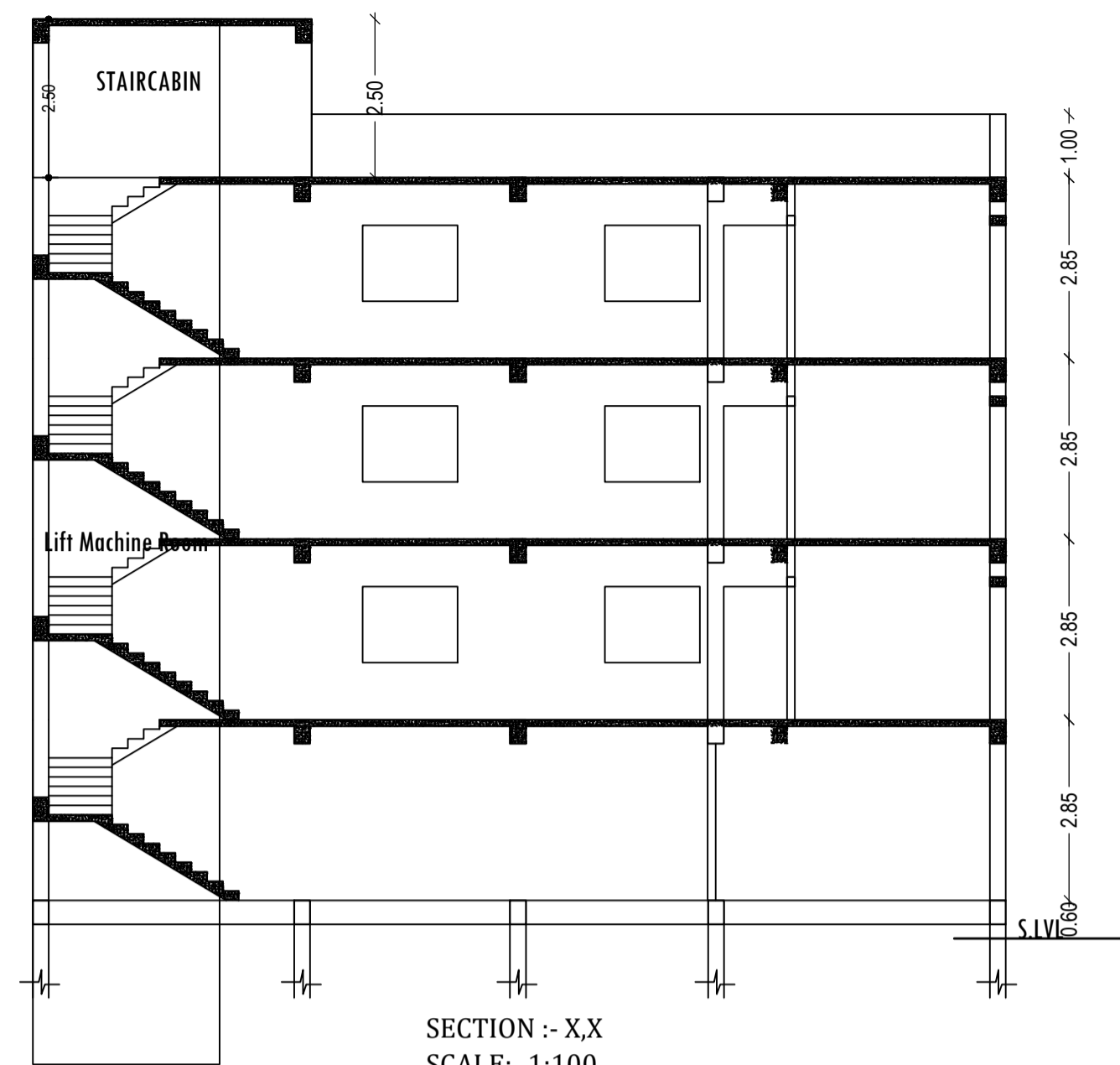

SECTION :- X,X SCALE:- 1:100

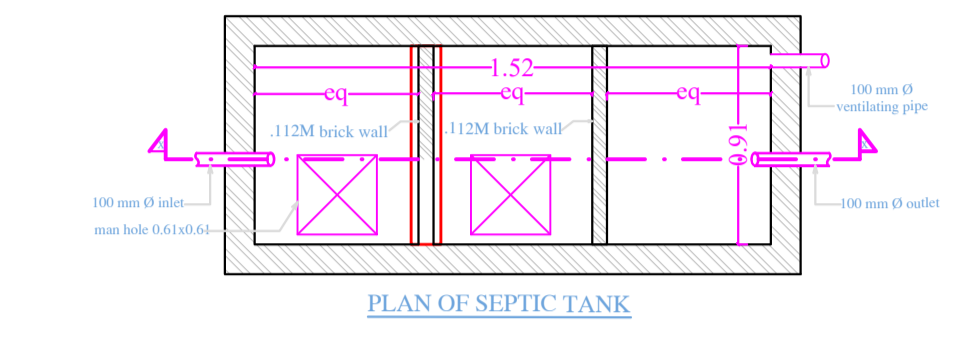

PLAN OF SEPTIC TANK

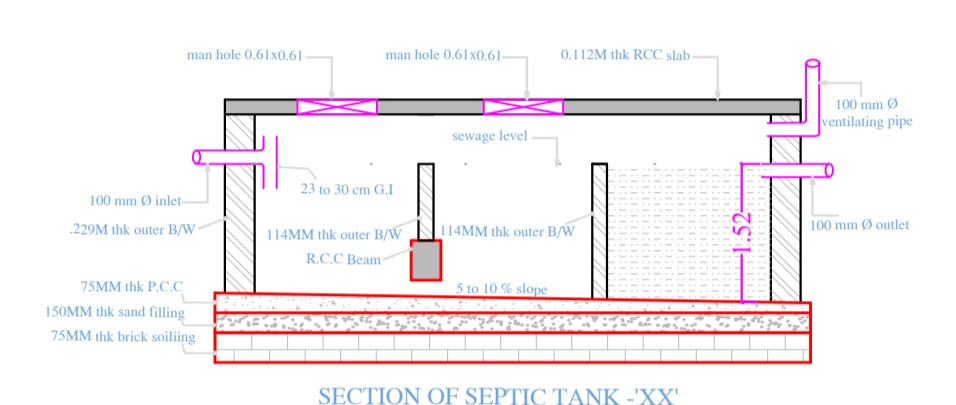

SECTION OF SEPTIC TANK -XX

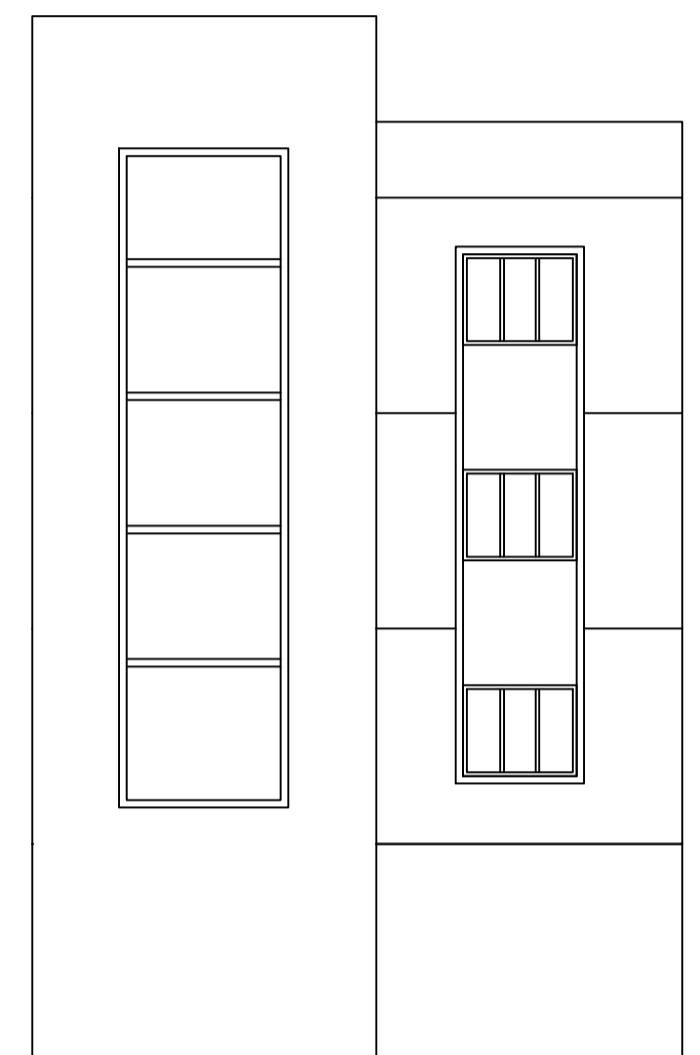

SIDE ELEVATION SCALE:- 1:100

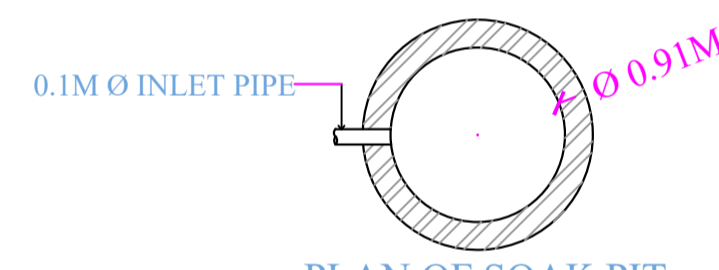

PLAN OF SOAK PIT

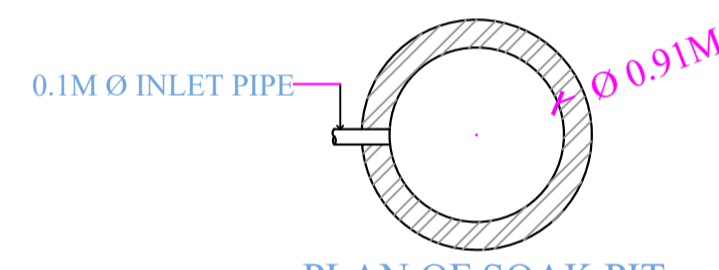

PLAN OF SOAK PIT

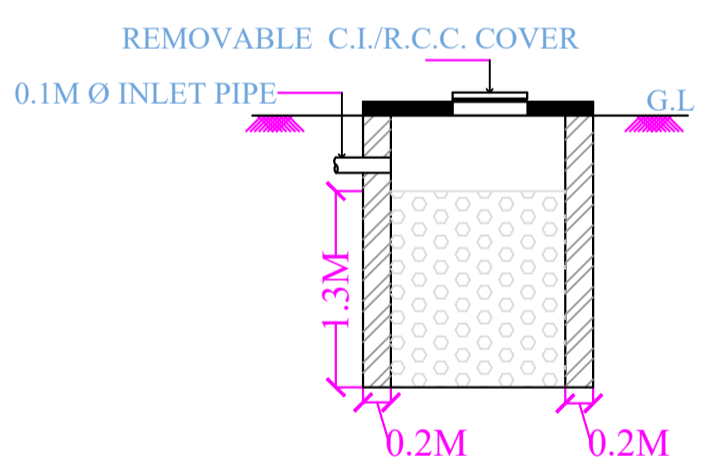

SECTION OF SOAK-PIT

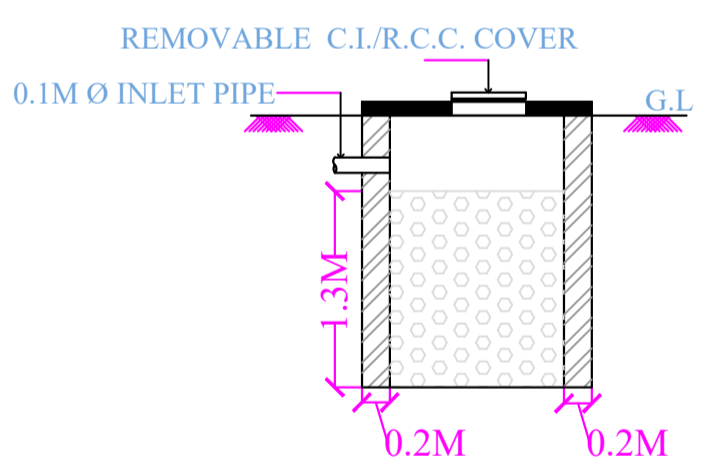

SECTION OF SOAK-PIT

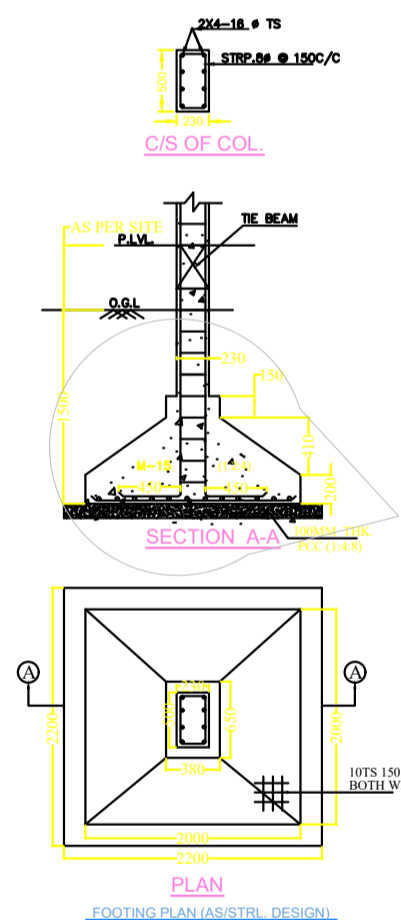

PLAN (FOOTING IS ON ASSISTED DESIGN) SCALE: 1:10



FRONT ELEVATION SCALE:- 1:100

SCHEDULE OF DOOR:

BUILDING NAME	NAME	LENGTH	HEIGHT	NOS
A (SHAKUNTALA DEVI SHAKUNTALA DEVI AGARWAL)	D2	0.75	2.13	06
A (SHAKUNTALA DEVI SHAKUNTALA DEVI AGARWAL)	D1	0.90	2.13	03
A (SHAKUNTALA DEVI SHAKUNTALA DEVI AGARWAL)	D	1.00	2.13	12

SCHEDULE OF WINDOW/VENTILATION:

BUILDING NAME	NAME	LENGTH	HEIGHT	NOS
A (SHAKUNTALA DEVI SHAKUNTALA DEVI AGARWAL)	V	0.60	0.60	09
A (SHAKUNTALA DEVI SHAKUNTALA DEVI AGARWAL)	W	1.50	1.20	18
A (SHAKUNTALA DEVI SHAKUNTALA DEVI AGARWAL)	W	2.00	1.20	06

UnitBUA Table for Building -A (SHAKUNTALA DEVI SHAKUNTALA DEVI AGARWAL)

FLOOR	Name	UnitBUA Type	UnitBUA Area	Carpet Area	No. of Rooms	No. of Tenement
TYPICAL - 1, 2& 3 FLOOR PLAN	SPLIT FLAT A	FLAT	103.54	98.78	8	3
Total:	-	-	310.62	296.35	24	3

Building -A (SHAKUNTALA DEVI SHAKUNTALA DEVI AGARWAL)

Floor Name	Total Built Up Area (Sq.mt.)	Deductions (Area in Sq.mt.)			Proposed FAR Area (Sq.mt.)	Add Area In FAR (Sq.mt.)	Total FAR Area (Sq.mt.)	Total Consumed Additional FAR Area (Sq.mt.)	Tnmt (No.)
		Lift	Parking	Resl.					
Ground Floor	144.47	0.00	127.76	0.00	13.15	16.71	16.71	00	
First Floor	131.97	3.56	0.00	128.41	0.00	128.41	128.41	01	
Second Floor	131.97	3.56	0.00	128.41	0.00	128.41	128.41	01	
Third Floor	131.97	3.56	0.00	128.41	0.00	128.41	128.41	01	
Terrace Floor	0.00	0.00	0.00	0.00	0.00	0.00	0.00	00	
Total :	540.38	10.68	127.76	385.23	13.15	401.94	401.94	03	
Total Number of Same Buildings	1								
Total :	540.38	10.68	127.76	385.23	13.15	401.94	401.94	03	

LTP NAME AND SIGNATURE	STRUCTURAL ENG'S NAME AND SIGNATURE	BUILDER NAME AND SIGNATURE	DIGITAL SIGNATURE
KUNAL GUIN CNP/ENG/0006/2017			