

Proposal Basic Information	
Proposal File No.	CNP/BP/0011/W01/2021
Owner Name	MR.ANIL KUMAR
Khata No	06
Plot No	152
Village Name	Pulhatu
Use	Residential
SubUse	Bungalow/ Dwelling / Non Apartment

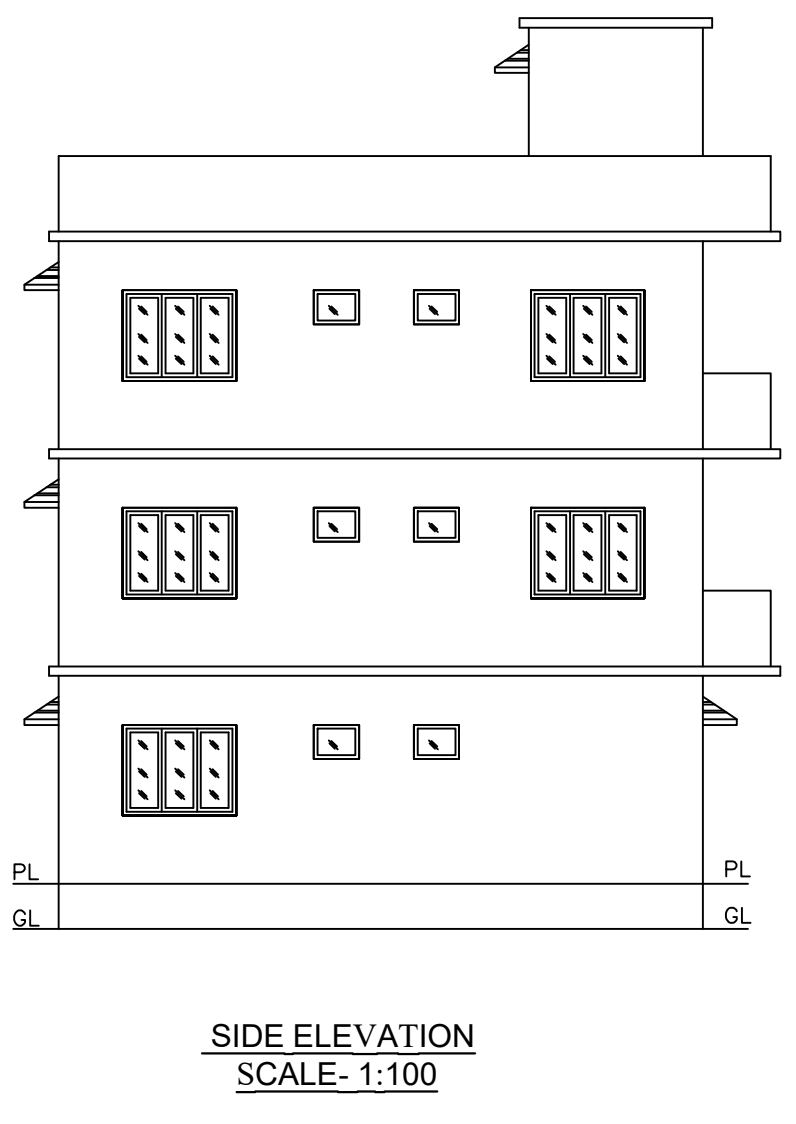
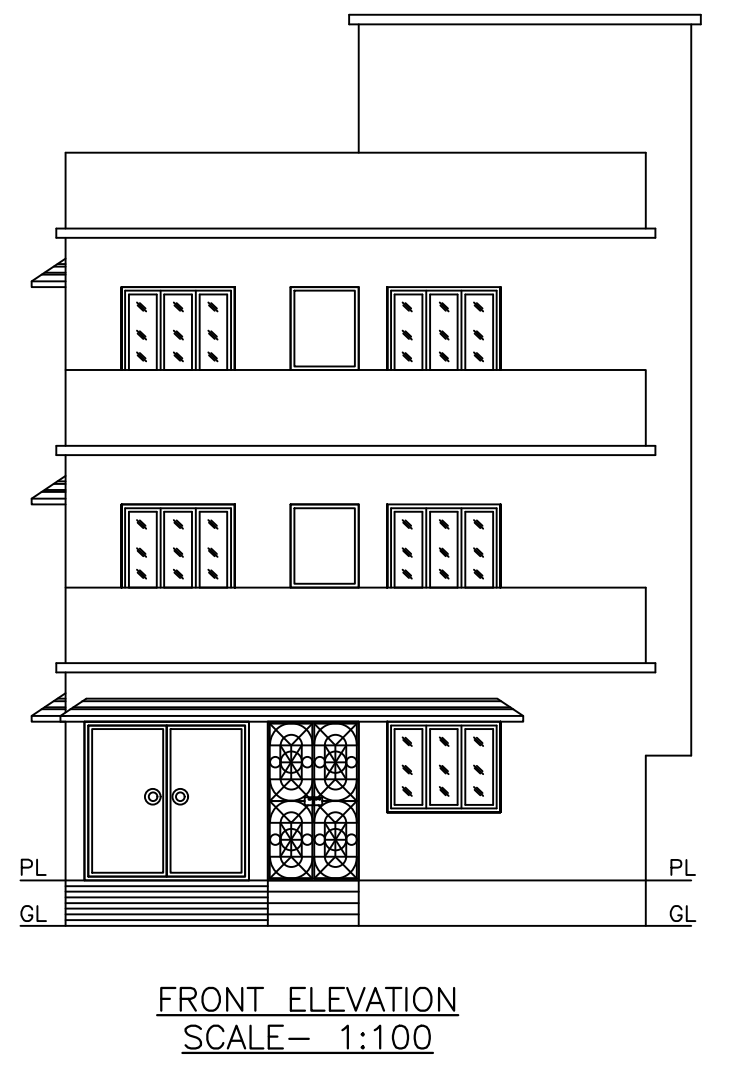
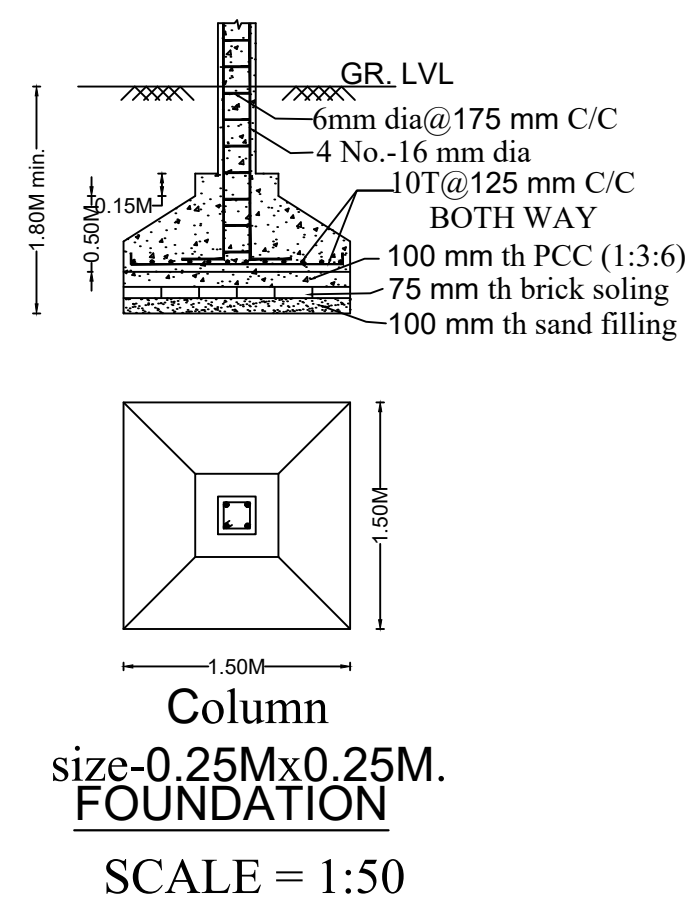
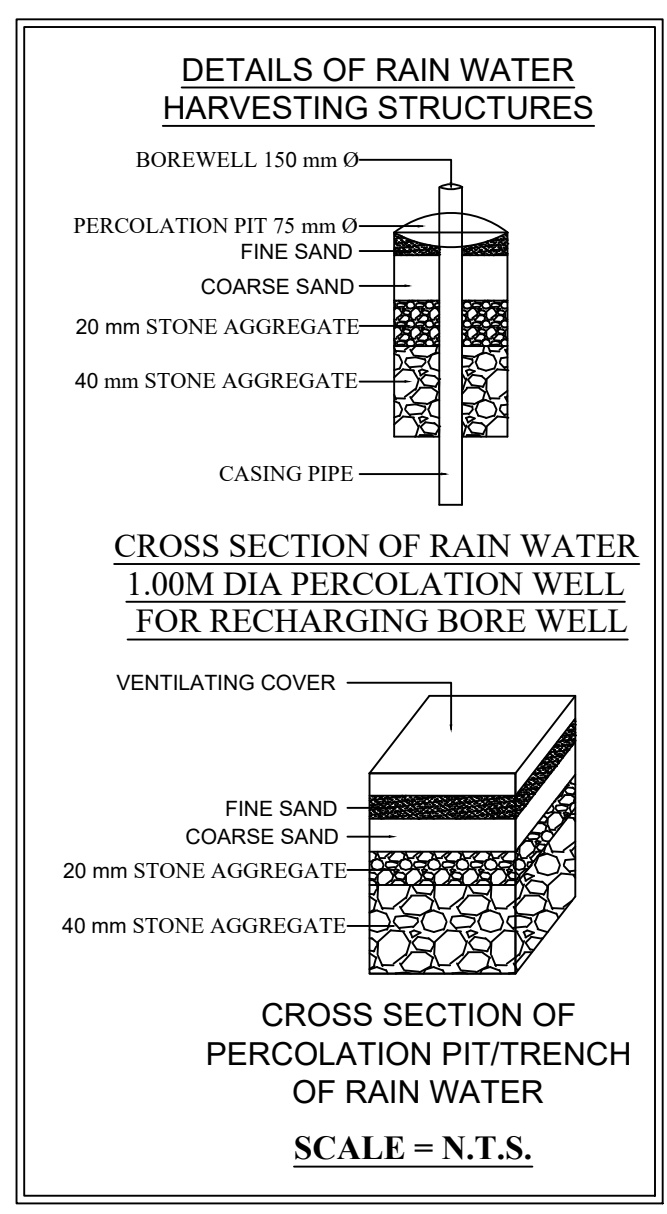
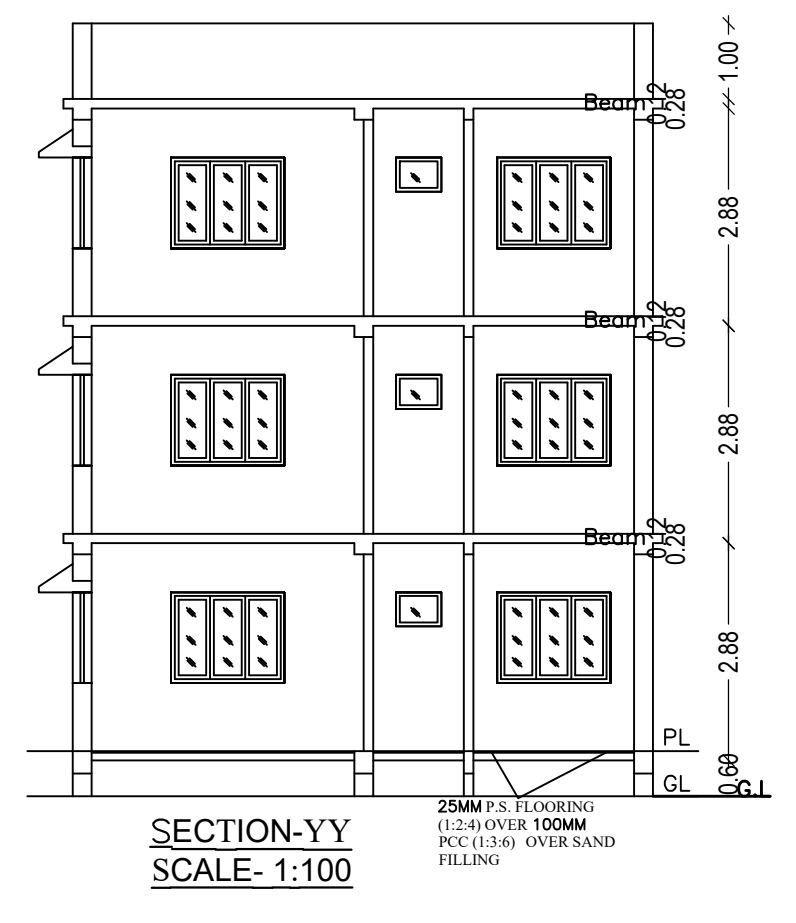
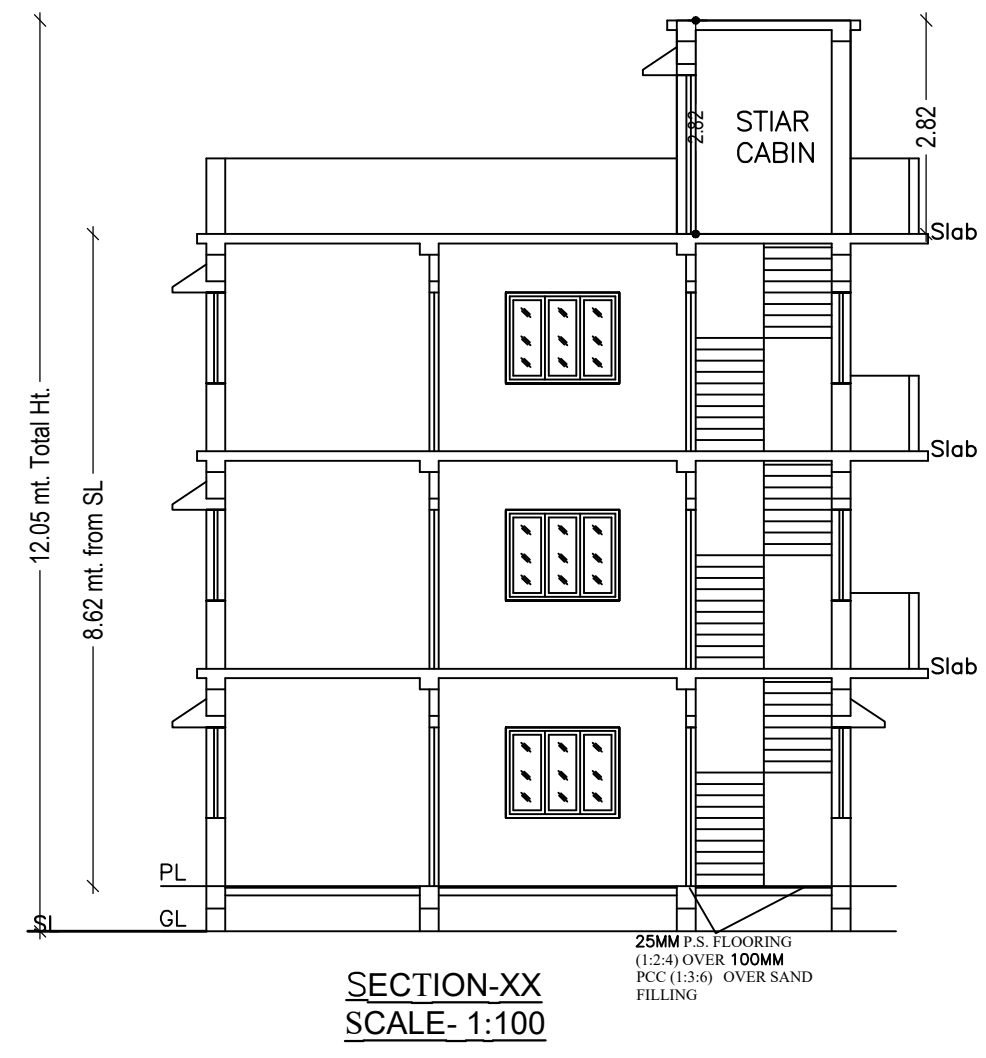
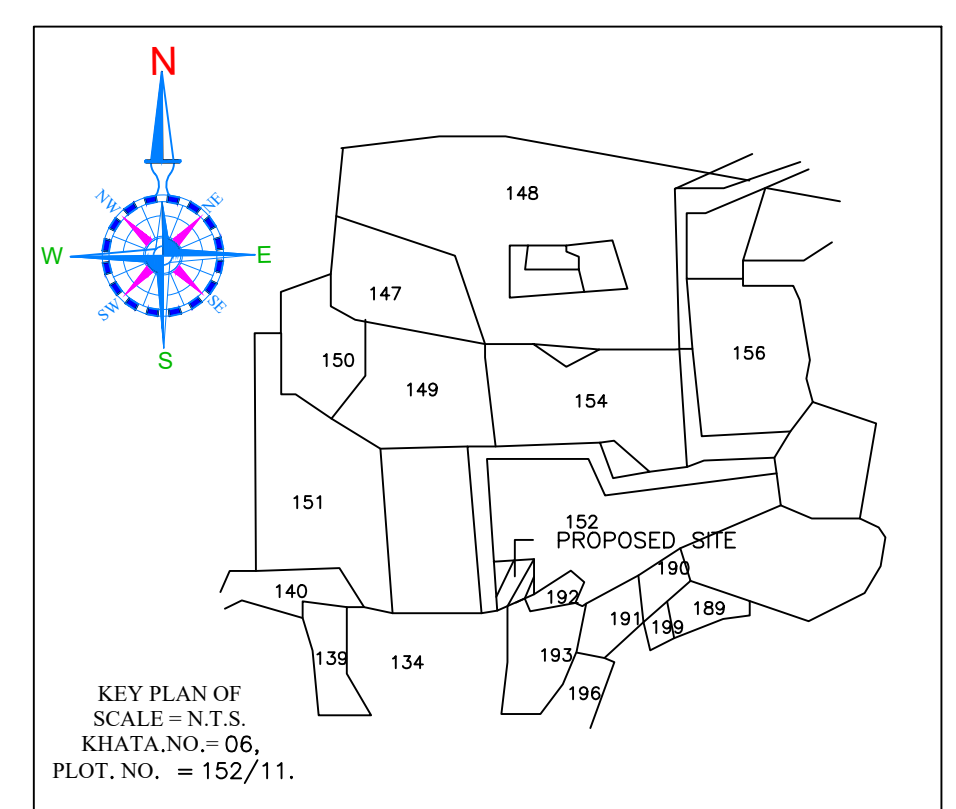
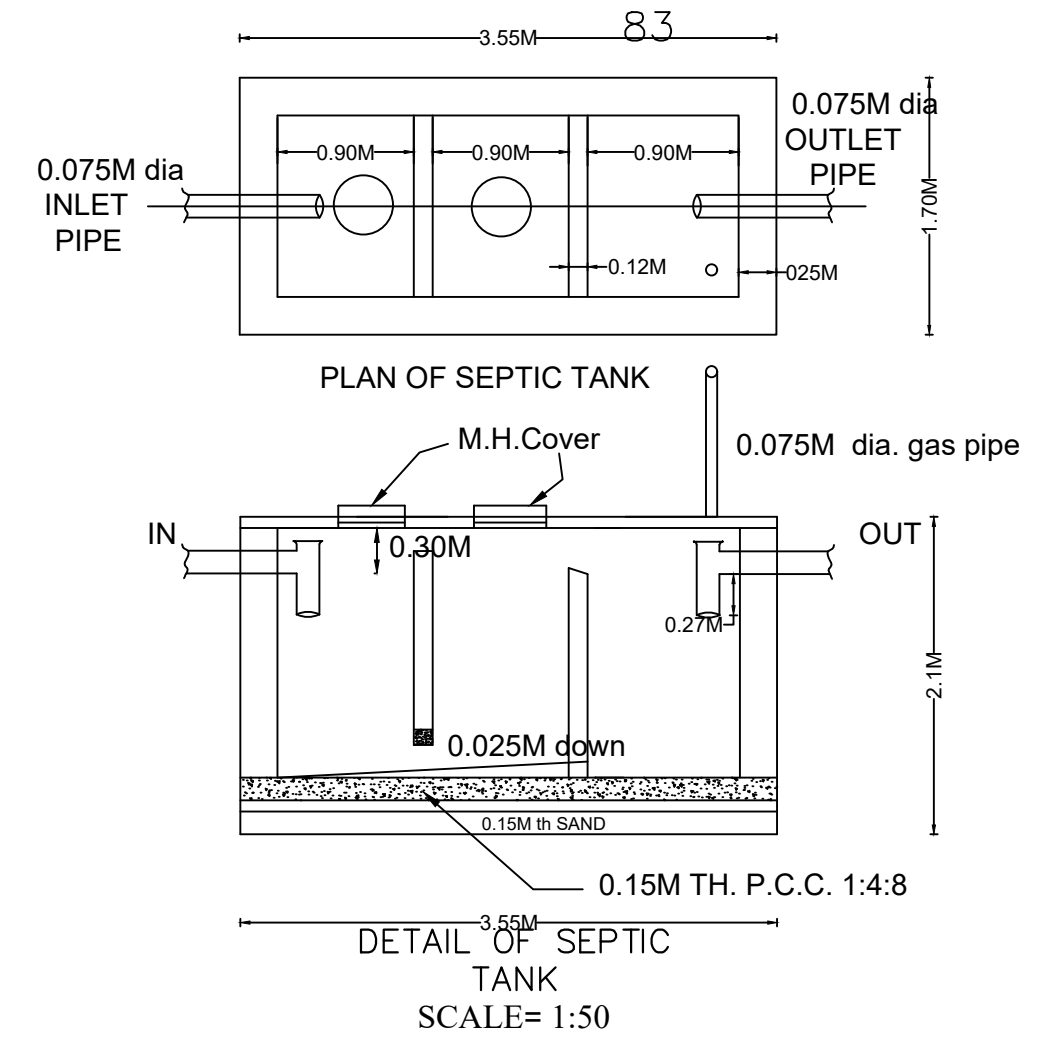
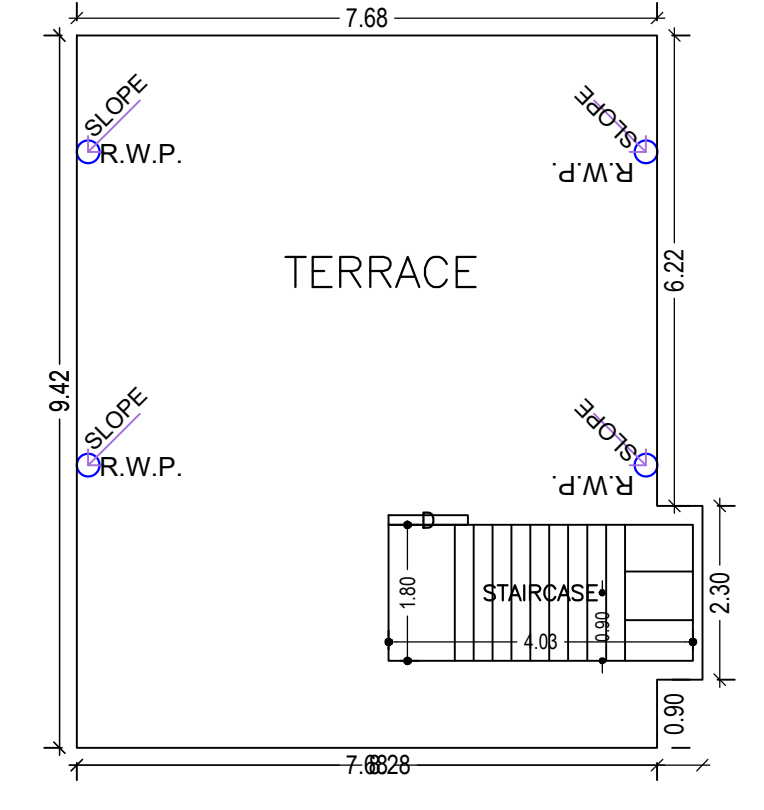
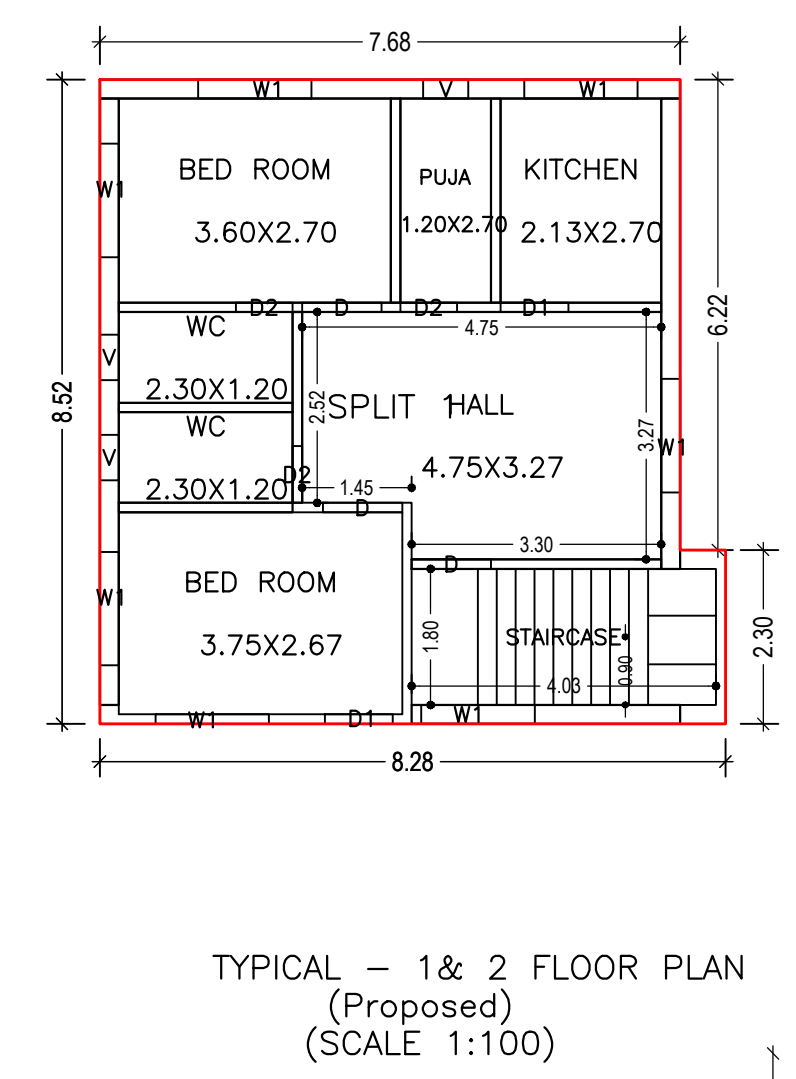
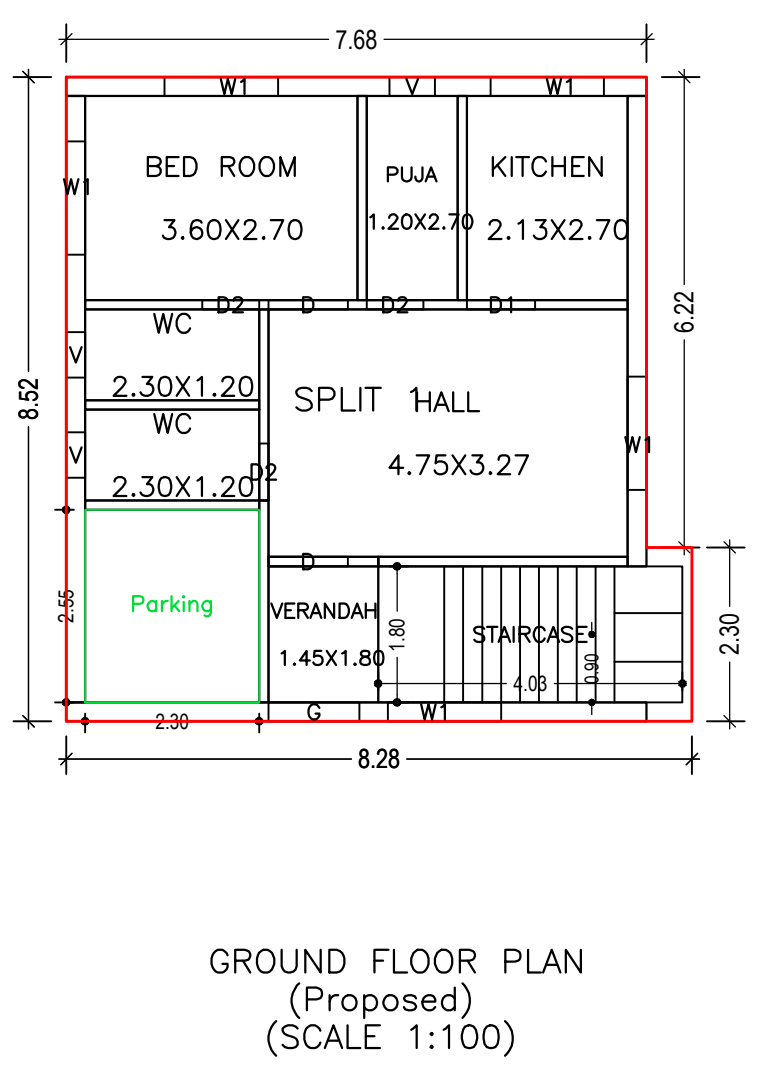
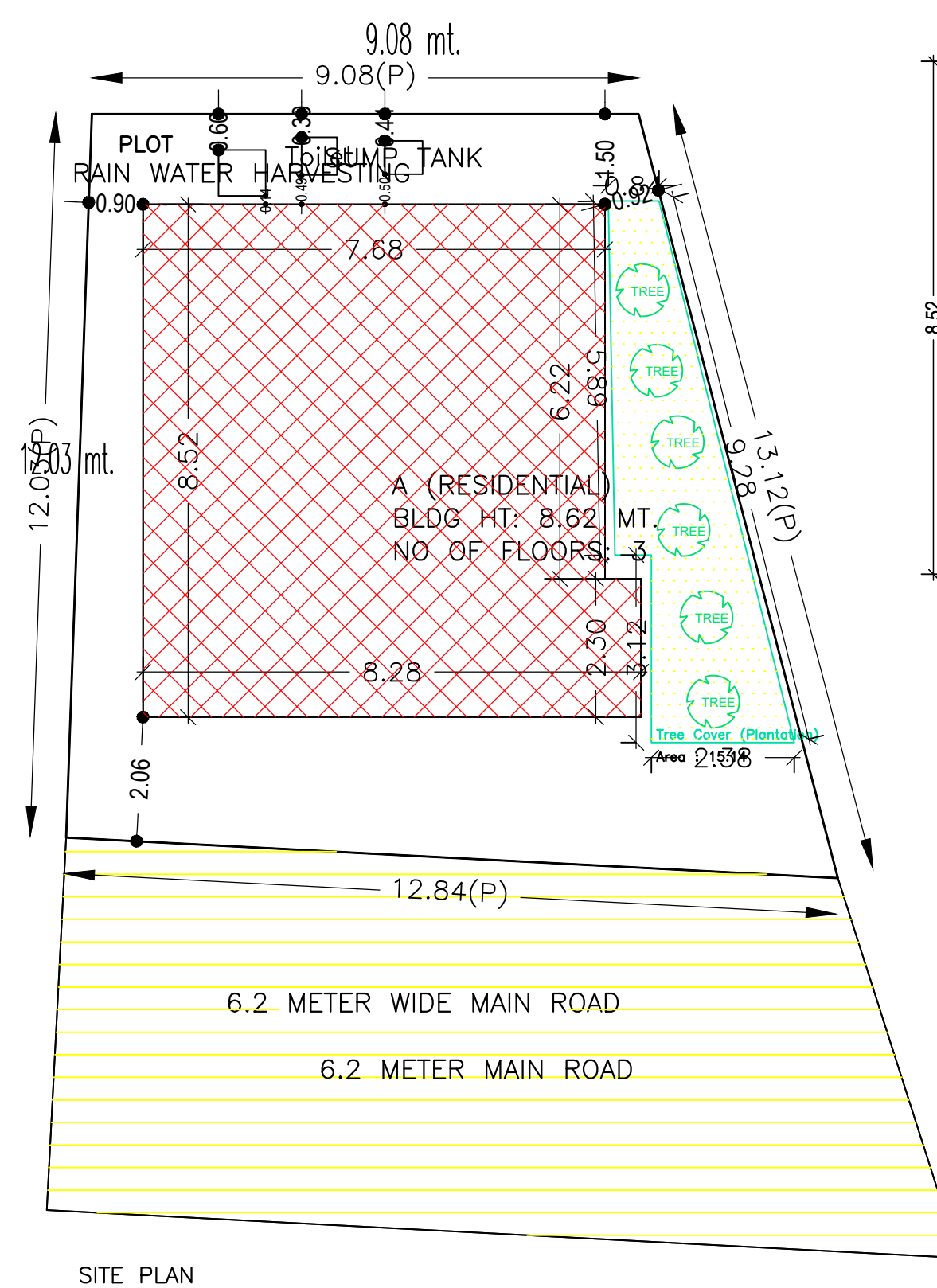

AREA STATEMENT	VERSION NO.: 1.0.54	SQ.MT.
CHAIBASA NAGAR	VERSION DATE: 16/10/2020	
PARISHAD		
PROJECT DETAIL:		
Region: JHARKHAND URBAN LOCAL BODIES	Plot Use: Residential	
District: WEST SINGBHUM	Plot SubUse: Bungalow/ Dwelling / Non Apartment	
Authority: CHAIBASA NAGAR PARISHAD	PlotNearby/ReligiousStructure: NA	
Inward No: CNP/BP/0011/W01/2021	Plot/SubPlot No: 152	
Application Type: General Proposal	North: Plot No. - 152	
Project Type: Building Permission	South: Plot No. - NUJ	
Nature of Development: New	East: Plot No. - 152	
Location of Development Area: Old Area	West: Road Width - 6.20	
AREA DETAILS:		
AREA OF PLOT (Minimum)	(A)	134.89
NET AREA OF PLOT(Gross Plot Area - Deduction from Gross Plot area)	(A-Deductions)	134.89
Deduction for Balance Plot Area(from Gross Plot Area)		
Common Plot		15.14
Total		15.14
BALANCE AREA OF PLOT(Net Plot Area - Recreational/Amenity space)	(A-Deductions)	119.75
PLOT AREA FOR COVERAGE(Net Plot Area for FAR (Net Plot Area + Road/Widening Area)	(A-Deductions)	134.89
COVERAGE CHECK		
Permissible Coverage area (70.00 %)		94.42
Proposed Coverage Area (49.51 %)		66.79
Total Prop. Coverage Area (49.51 %)		66.79
Balance coverage area (20.48 %)		27.63
FAR CHECK		
Perm. FAR Area (2.00)		269.78
Total Perm. FAR area		269.78
Residential FAR		200.38
Proposed FAR Area		200.38
Total Proposed FAR Area		200.38
Consumed FAR (Factor)		1.49
Balance FAR Area		69.40
BUILT UP AREA CHECK		
Total Proposed BuiltUp Area		200.37
ARCHITECT (Regd)	ARUN SINGH	
ENGINEER (Regd)		
SUPERVISOR (Regd)		
OWNER (Regd)	MR.ANIL KUMAR	
DEVELOPMENT AUTHORITY	LOCAL BODY	

Building :A (RESIDENTIAL)					
Floor Name	Total Built Up Area (Sq.mt.)	Proposed FAR Area (Sq.mt.) Resi.	Total FAR Area (Sq.mt.)	Total Consumed Additional FAR Area (Sq.mt.)	Trmt (No.)
Ground Floor	66.79	66.79	66.79	66.79	01
First Floor	66.79	66.79	66.79	66.79	00
Second Floor	66.79	66.79	66.79	66.79	00
Terrace Floor	0.00	0.00	0.00	0.00	00
Total	200.37	200.37	200.37	200.37	01
Total Number of Same Buildings	1				
Total	200.37	200.37	200.37	200.37	01

SCHEDULE OF DOOR:				
BUILDING NAME	NAME	LENGTH	HEIGHT	NOS
A (RESIDENTIAL)	D2	0.75	2.10	09
A (RESIDENTIAL)	D1	0.90	2.10	05
A (RESIDENTIAL)	D	1.05	2.10	08
A (RESIDENTIAL)	G	1.20	2.10	01

SCHEDULE OF WINDOW/VENTILATION:				
BUILDING NAME	NAME	LENGTH	HEIGHT	NOS
A (RESIDENTIAL)	V	0.60	1.20	09
A (RESIDENTIAL)	W1	1.50	1.20	19

Buildingwise Floor FAR Details				
Floor Name	Building Name		Total	
	Proposed Built Up Area (Sq.mt.)	Proposed FAR Area (Sq.mt.)	Total Proposed Built Up Area (Sq.mt.)	Total FAR Area (Sq.mt.)
Ground Floor	66.79	66.79	66.79	66.79
First Floor	66.79	66.79	66.79	66.79
Second Floor	66.79	66.79	66.79	66.79
Terrace Floor	0.00	0.00	0.00	0.00
Total	200.37	200.37	200.37	200.37

Building USE/SUBUSE Details			
Building Name	Building Use	Building SubUse	Building Structure
A (RESIDENTIAL)	Residential	Bungalow/ Dwelling / Non Apartment	Non-Highrise

UnitBUA Table for Building :A (RESIDENTIAL)						
FLOOR	Name	UnitBUA Type	UnitBUA Area	Carpet Area	No. of Rooms	No. of Tenement
GROUND FLOOR PLAN	SPLIT 1	FLAT	148.13	140.84	7	1
TYPICAL - 1& 2 FLOOR PLAN	SPLIT 1	FLAT	0.00	0.00	7	0
Total:	-	-	148.13	140.84	21	1

FAR & Tenement Details (Table 4c-1)						
Building	No. of Same Bldg	Total Built Up Area (Sq.mt.)	Proposed FAR Area (Sq.mt.) Resi.	Total FAR Area (Sq.mt.)	Total Consumed Additional FAR Area (Sq.mt.)	Trmt (No.)
A (RESIDENTIAL)	1	200.37	200.37	200.37	200.37	01
Grand Total :	1	200.37	200.37	200.37	200.37	01

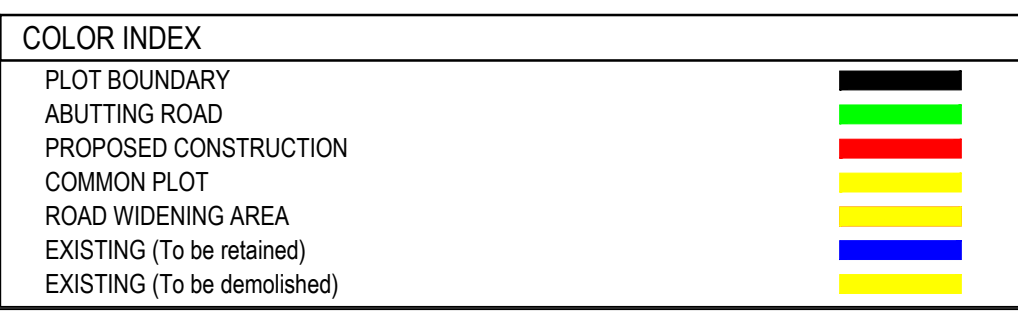

LTP NAME AND SIGNATURE	STRUCTURAL ENG'S NAME AND SIGNATURE	BUILDER NAME AND SIGNATURE	DIGITAL SIGNATURE
ARUN SINGH CNP/ENG/0005/2020			