

Proposal Basic Information

Proposal File No.	CNP/BB/0035/W19/2021
Owner Name	MRS.REKHA DEV BURMAN, MR.RAJESH DEV BURMAN AND MR.RITESH DEV BURMAN
Khata No	87
Plot No	365(a,b,c,d)
Village Name	Tungri
Use	Residential
SubUse	Bungalow/ Dwelling / Non Apartment

AREA STATEMENT CHAIBASA NAGAR PARISHAD

Region: JHARKHAND URBAN LOCAL BODIES	Plot Use: Residential
District: WEST SINGBHMUM	Plot SubUse: Bungalow/ Dwelling / Non Apartment
Authority: CHAIBASA NAGAR PARISHAD	Plot/Nearby/ReligiousStructure: NA
Inward No: CNP/BB/0035/W19/2021	Plot/SubPlot No: 365(a,b,c,d)
Application Type: General Proposal	North: Plot No. - NIJ
Project Type: Building Permission	South: Plot No. - NIJ
Nature of Development: New	East: Road Width - 6.20
Location of Development Area: Old Area	West: Plot No. - NIJ

AREA DETAILS:

AREA OF PLOT (Minimum)	(A)	SQ.MT.
NET AREA OF PLOT(Gross Plot Area - Deduction from Gross Plot area)	(A-Deductions)	151.11
Deduction for Balance Plot Area(from Gross Plot Area)		
Common Plot		13.65
Total		13.65
BALANCE AREA OF PLOT(Net Plot Area - Recreational/Amenity space)	(A-Deductions)	137.46
PLOT AREA FOR COVERAGE(Net Plot Area)	(A-Deductions)	151.11
Plot Area for FAR (Net Plot Area + Road Widening Area)	(A-Deductions)	151.11

COVERAGE CHECK

Permissible Coverage area (70.00 %)	105.78
Proposed Coverage Area (60.59 %)	91.55
Total Prop. Coverage Area (60.59 %)	91.55
Balance coverage area (9.42 %)	14.23

FAR CHECK

Perm. FAR Area (2.00)	302.22
Total Perm. FAR area	302.22
Residential FAR	184.74
Proposed FAR Area	184.74
Total Proposed FAR Area	184.74
Consumed FAR (Factor)	1.22
Balance FAR Area	117.48

BUILT UP AREA CHECK

Total Proposed BuiltUp Area	186.36
-----------------------------	--------

ARCHITECT (Regd) SAQUIB JAWED
ENGINEER (Regd)
SUPERVISOR (Regd)
OWNER (Regd) MRS.REKHA DEV BURMAN, MR.RAJESH DEV BURMAN AND MR.RITESH DEV BURMAN
DEVELOPMENT AUTHORITY LOCAL BODY

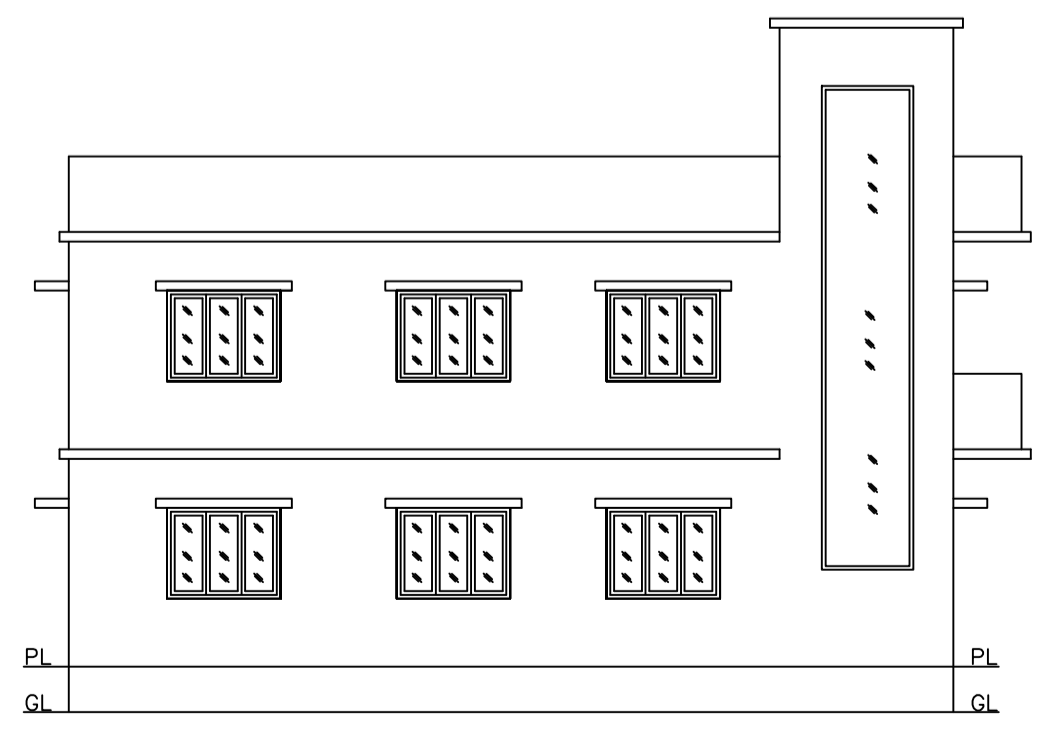
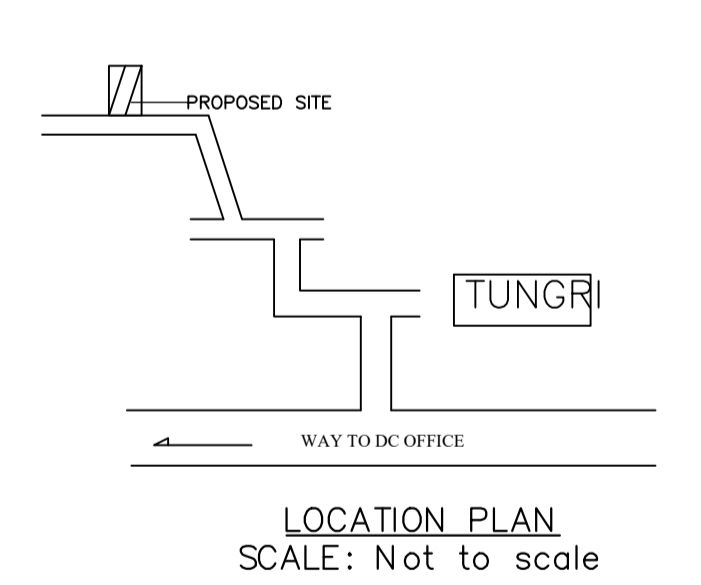
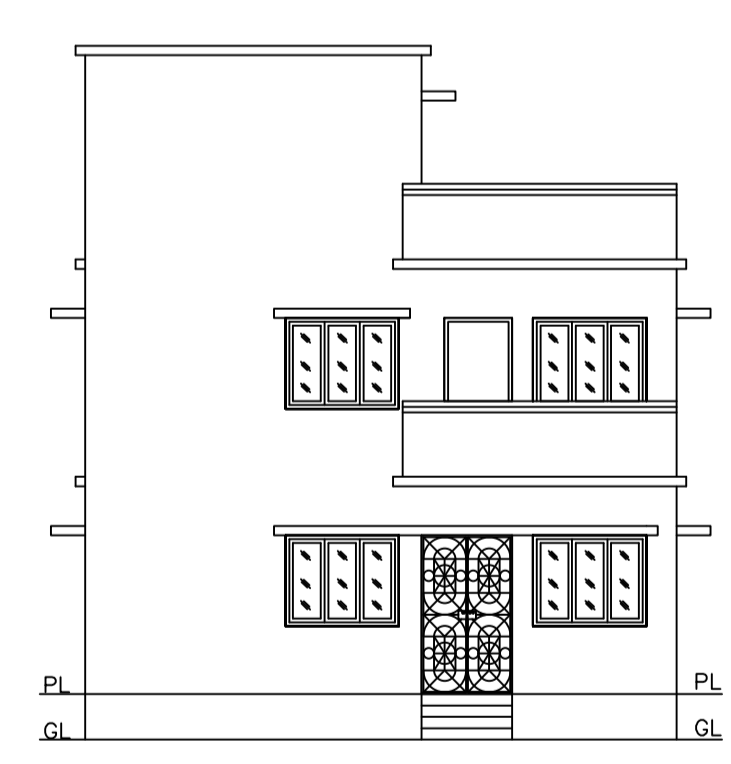
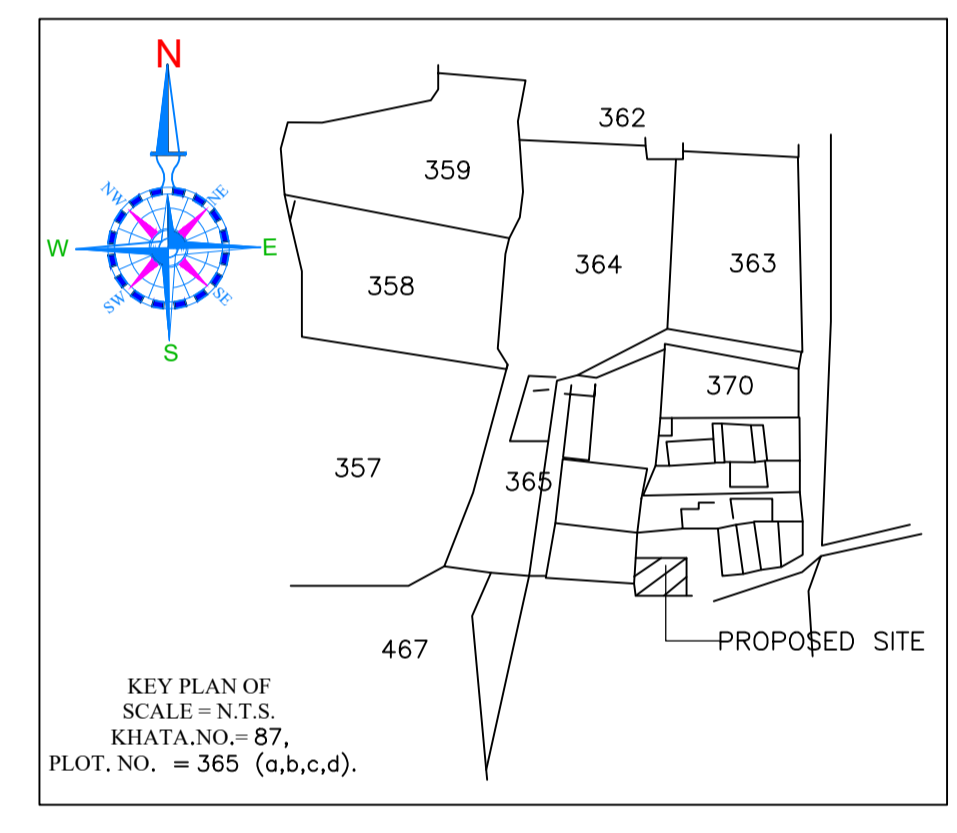
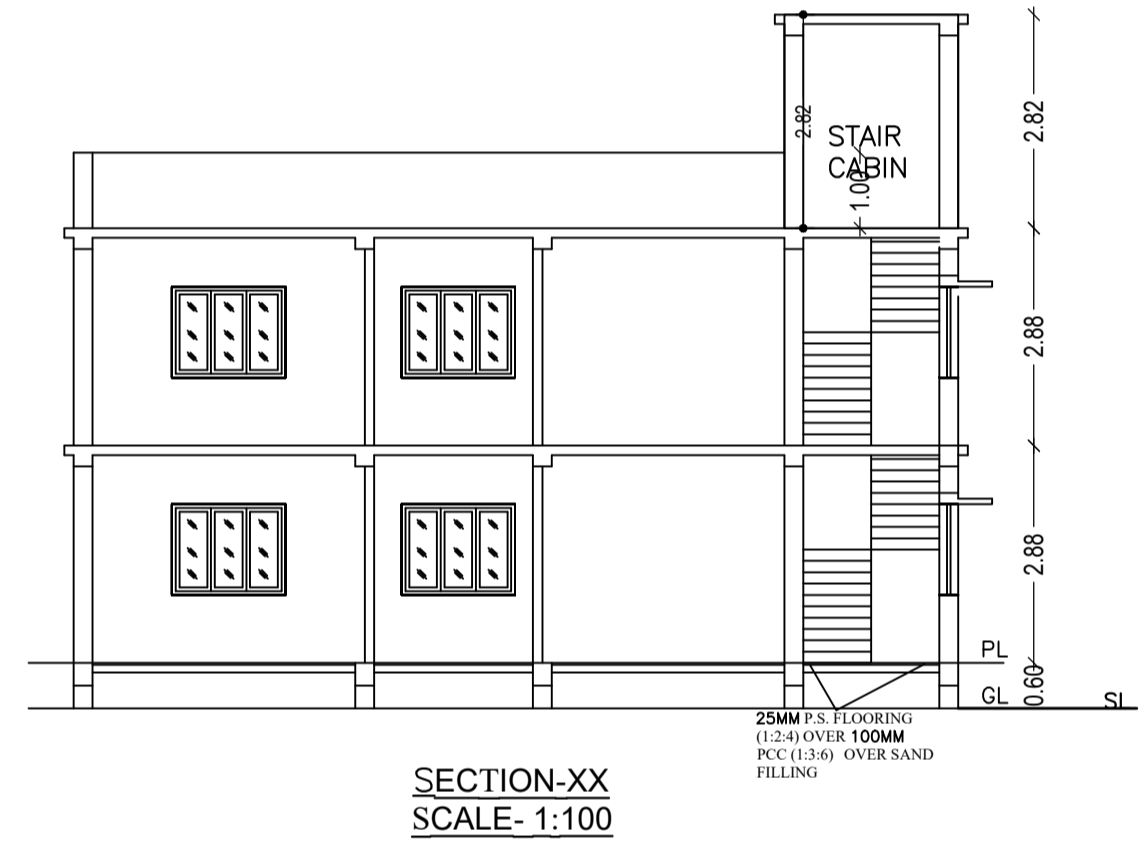
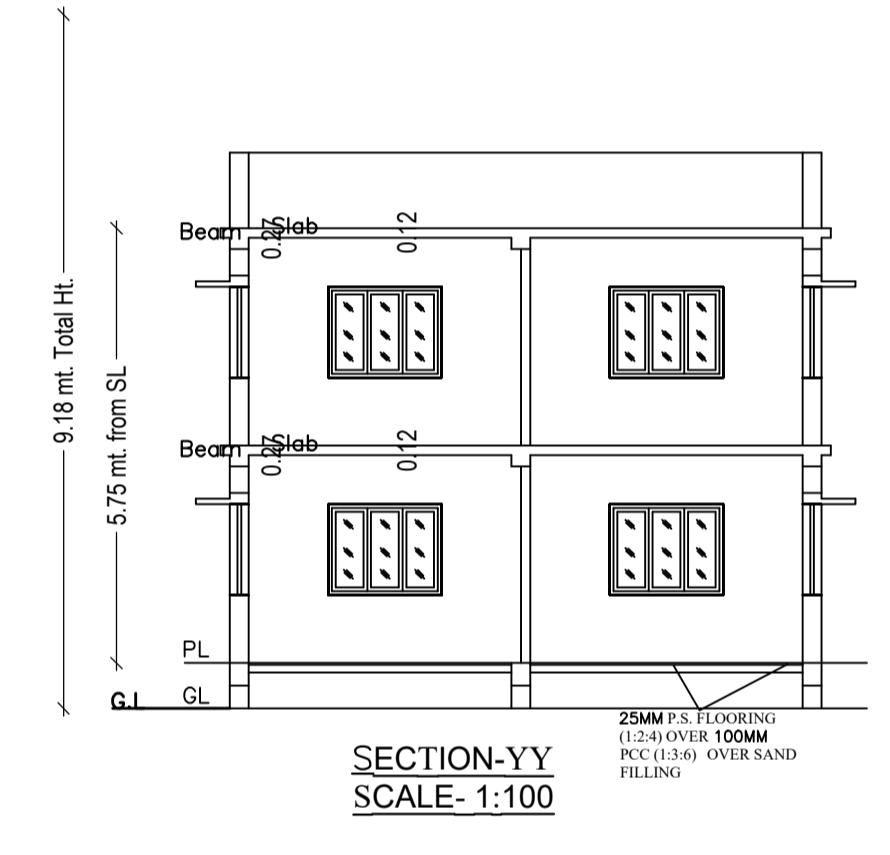
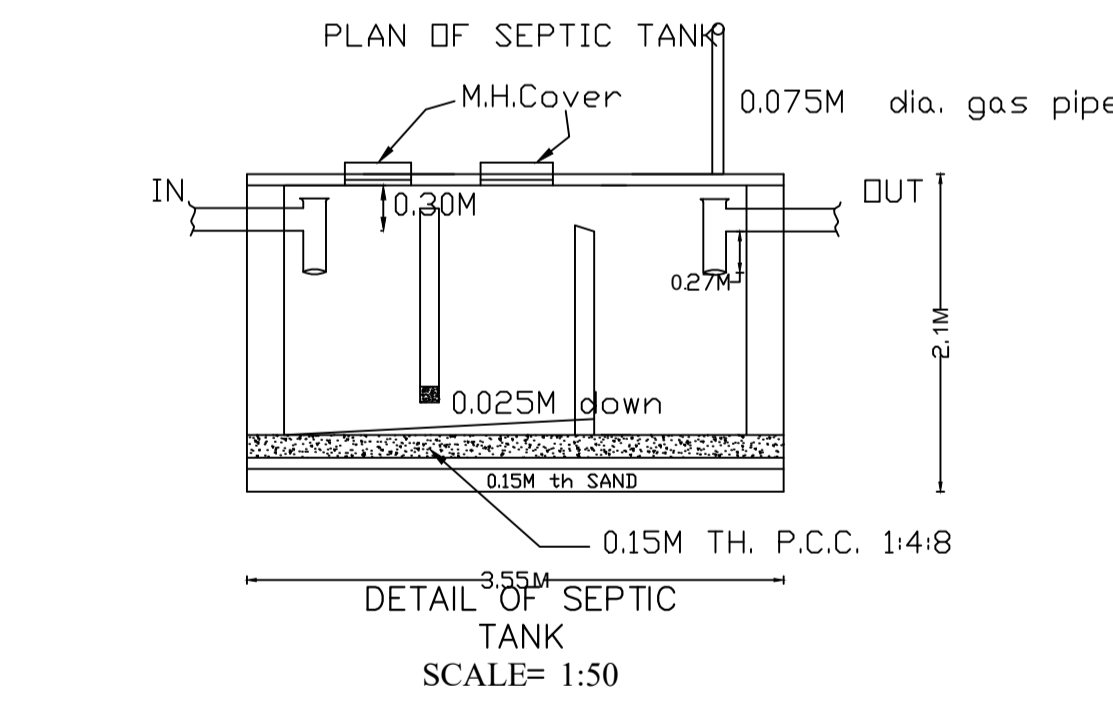
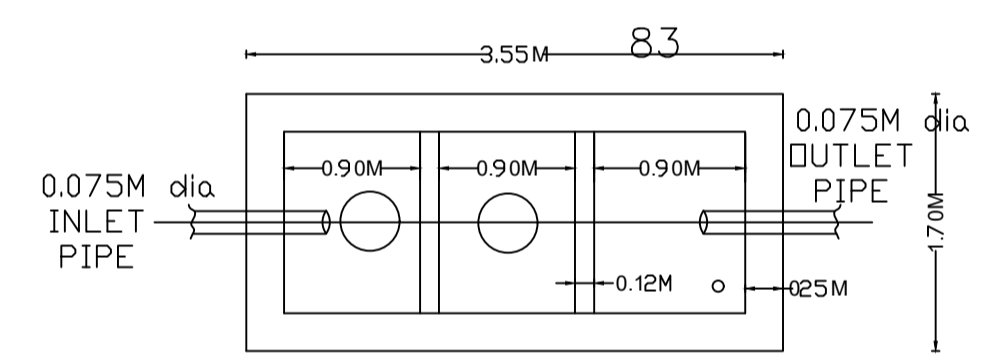

Building USE/SUBUSE Details

Building Name	Building Use	Building SubUse	Building Structure
A (RESIDENTIAL)	Residential	Bungalow/ Dwelling / Non Apartment	Non-Highrise

Building :A (RESIDENTIAL)

Floor Name	Total Built Up Area (Sq.mt.)	Deductions (Area in Sq.mt.)	Proposed FAR Area (Sq.mt.)	Total FAR Area (Sq.mt.)	Total Consumed Additional FAR Area (Sq.mt.)	Tnmt (No.)
Ground Floor	91.55	0.00	91.55	91.55	91.55	01
First Floor	94.81	1.63	93.18	93.18	93.18	00
Terrace Floor	0.00	0.00	0.00	0.00	0.00	00
Total :	186.36	1.63	184.73	184.73	184.73	01

SCHEDULE OF DOOR:

BUILDING NAME	NAME	LENGTH	HEIGHT	NOS
A (RESIDENTIAL)	D2	0.75	2.10	04
A (RESIDENTIAL)	D1	0.90	2.10	04
A (RESIDENTIAL)	D	1.05	2.10	04
A (RESIDENTIAL)	G	1.20	2.10	02

SCHEDULE OF WINDOW/VENTILATION:

BUILDING NAME	NAME	LENGTH	HEIGHT	NOS
A (RESIDENTIAL)	V	0.60	1.20	04
A (RESIDENTIAL)	W1	1.50	1.20	18

Buildingwise Floor FAR Details

Floor Name	Building Name A (RESIDENTIAL)		Total	
	Proposed Built Up Area (Sq.mt.)	Proposed FAR Area (Sq.mt.)	Total Proposed Built Up Area (Sq.mt.)	Total FAR Area (Sq.mt.)
Ground Floor	91.55	91.55	91.55	91.55
First Floor	94.81	93.18	94.81	93.18
Terrace Floor	0.00	0.00	0.00	0.00
Total :	186.36	184.73	186.36	184.73

Balcony Calculations Table

FLOOR	SIZE	AREA	TOTAL AREA
FIRST FLOOR PLAN	0.90 X 3.63 X 1 X 1	3.26	3.26
Total	-	-	3.26

UnitBUA Table for Building :A (RESIDENTIAL)

FLOOR	Name	UnitBUA Type	UnitBUA Area	Carpet Area	No. of Rooms	No. of Tenement
GROUND FLOOR PLAN	SPLIT 1	FLAT	141.43	140.53	8	1
FIRST FLOOR PLAN	SPLIT 1	FLAT	0.00	0.00	8	0
Total:	-	-	141.43	140.53	16	1

FAR & Tenement Details (Table 4c-1)

Building	No. of Same Bldg	Total Built Up Area (Sq.mt.)	Deductions (Area in Sq.mt.)		Proposed FAR Area (Sq.mt.)	Total FAR Area (Sq.mt.)	Total Consumed Additional FAR Area (Sq.mt.)	Tnmt (No.)
			Balcony	Rest.				
A (RESIDENTIAL)	1	186.36	1.63	184.73	184.73	184.73	184.73	01
Grand Total :	1	186.36	1.63	184.73	184.73	184.73	184.73	01

COLOR INDEX

PLOT BOUNDARY	Black
ABUTTING ROAD	Green
PROPOSED CONSTRUCTION	Red
COMMON PLOT	Yellow
ROAD WIDENING AREA	Blue
EXISTING (To be retained)	Orange
EXISTING (To be demolished)	Light Blue

LTP NAME AND SIGNATURE

LTP NAME AND SIGNATURE	STRUCTURAL ENG'S NAME AND SIGNATURE	BUILDER NAME AND SIGNATURE	DIGITAL SIGNATURE
SAQUIB JAWED CNP/ENG/0007/2021			