

Proposal Basic Information	
Proposal File No.	CNP/BP/0004/W01/2022
Owner Name	VITIKANT RAUT
Khata No	10
Plot No	282 D
Village Name	Pulhatu
Use	Residential
SubUse	Bungalow/ Dwelling / Non Apartment

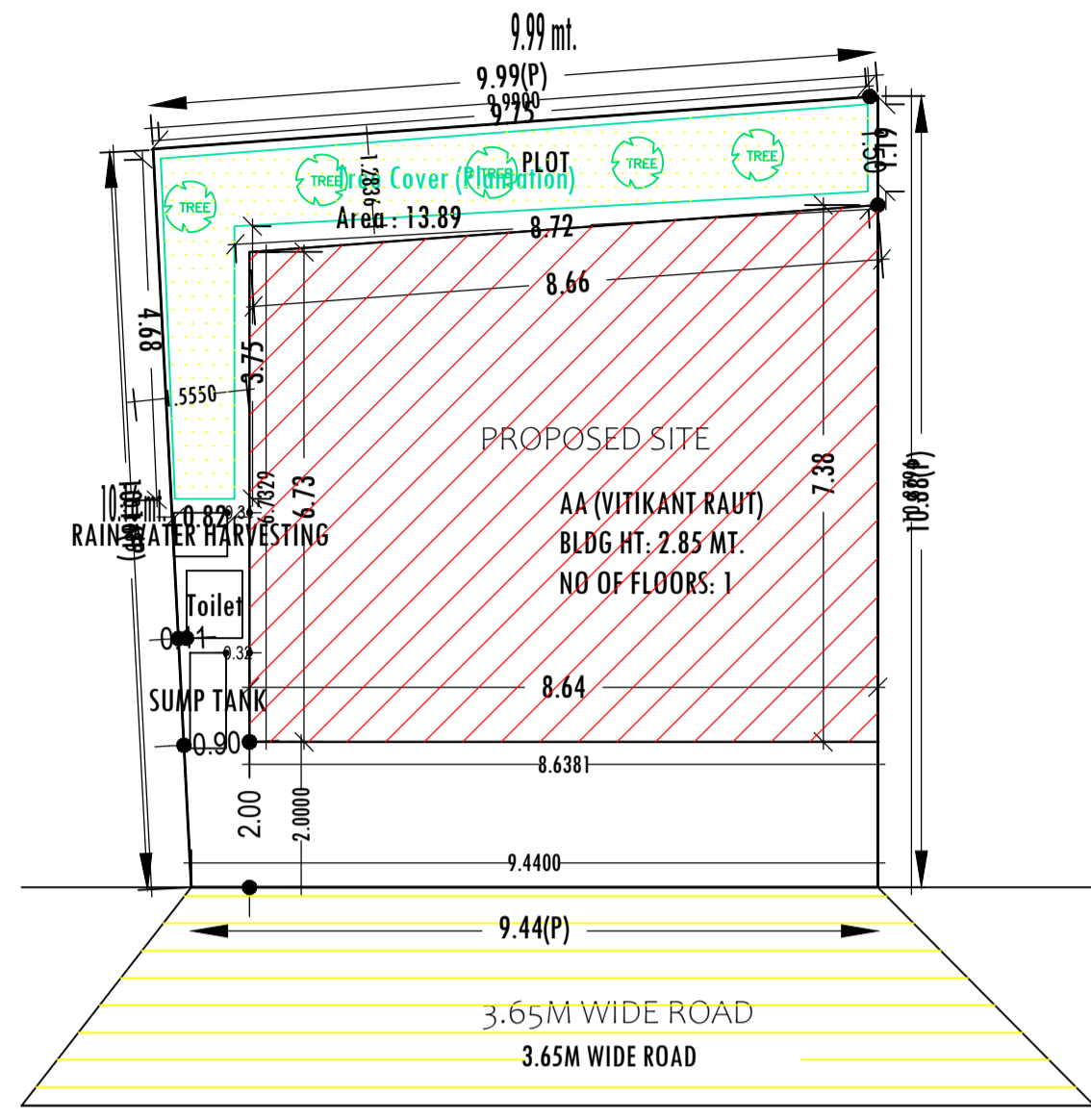

SITE PLAN
SCALE:-1:100

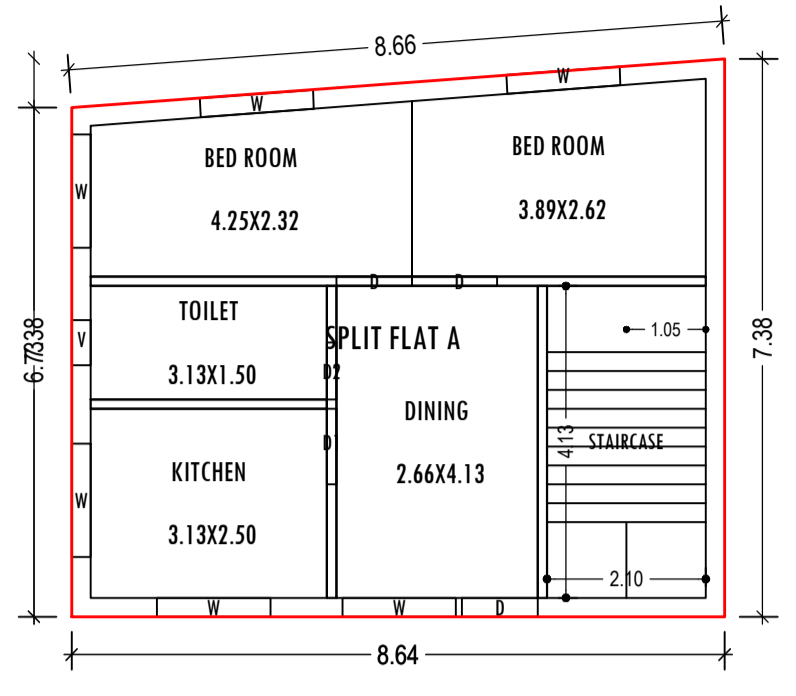

GROUND FLOOR PLAN
(Proposed)
SCALE 1:100

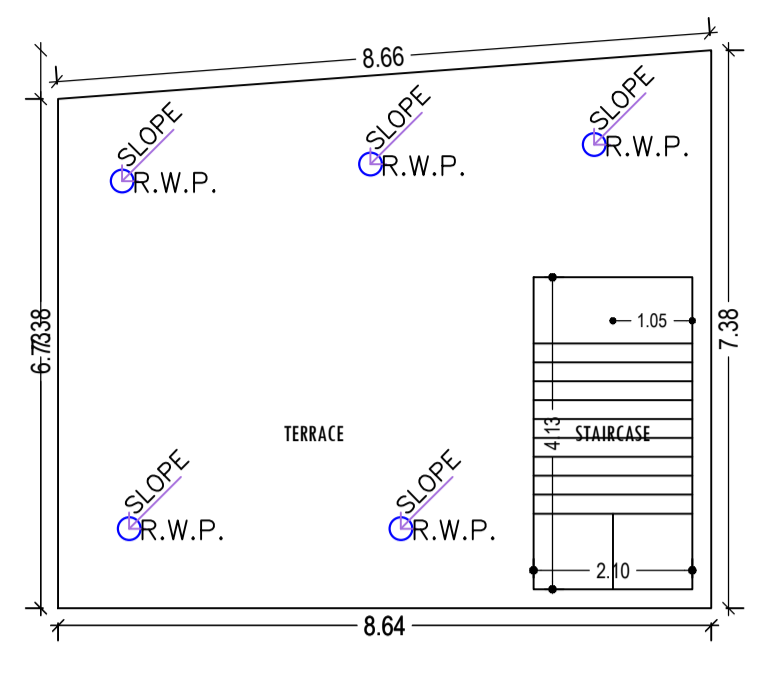

TERRACE FLOOR PLAN
SCALE 1:100

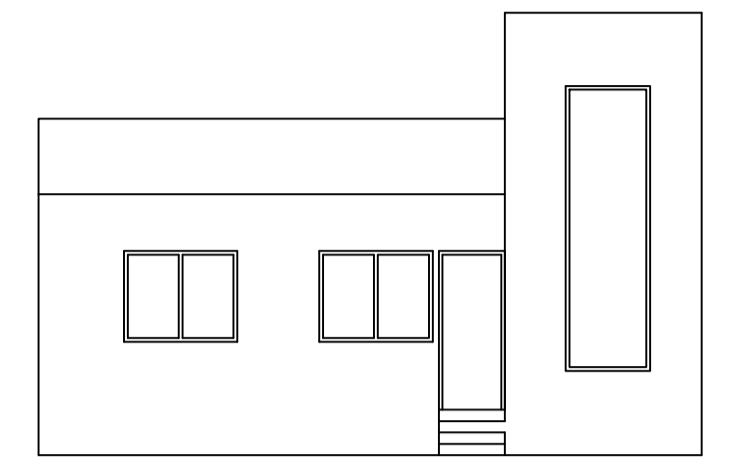

FRONT ELEVATION
SCALE:-1:100

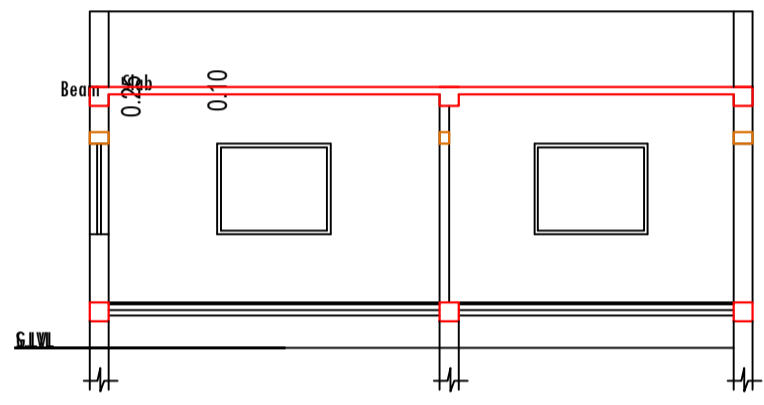

SECTION:- X-X
SCALE:-1:100

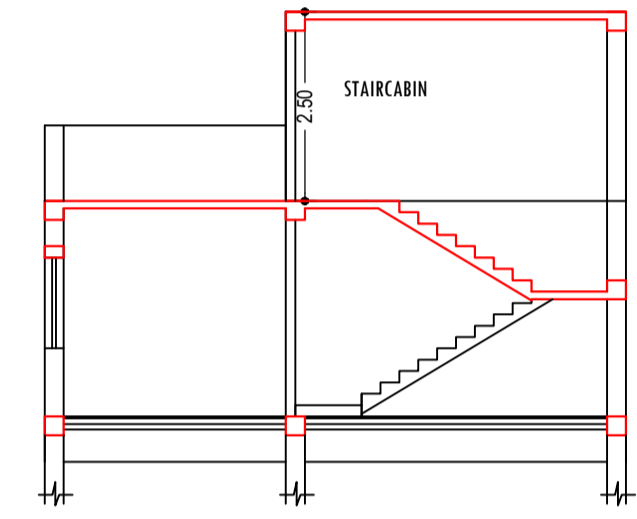

SECTION:- Y-Y
SCALE:-1:100

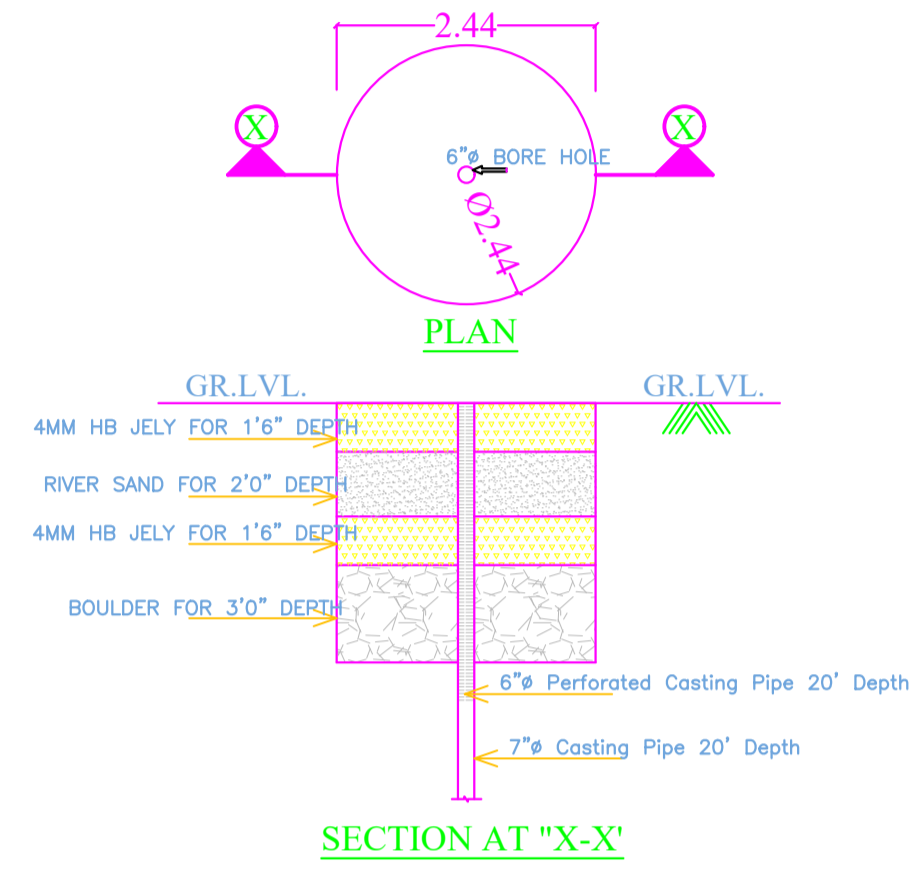

SECTION AT "X-X"

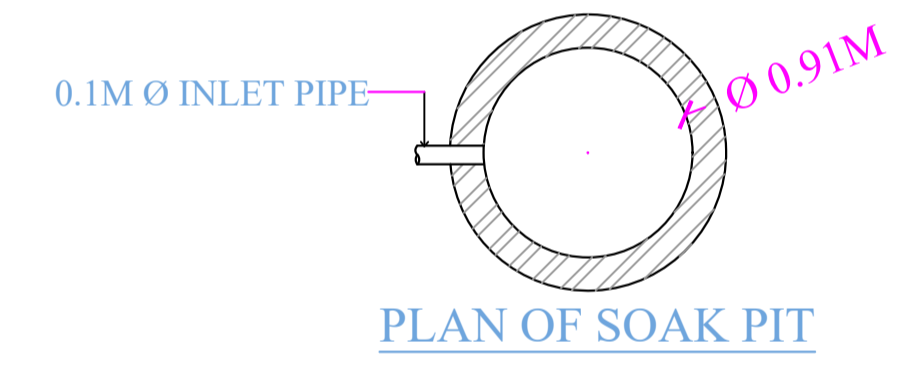

PLAN OF SOAK PIT

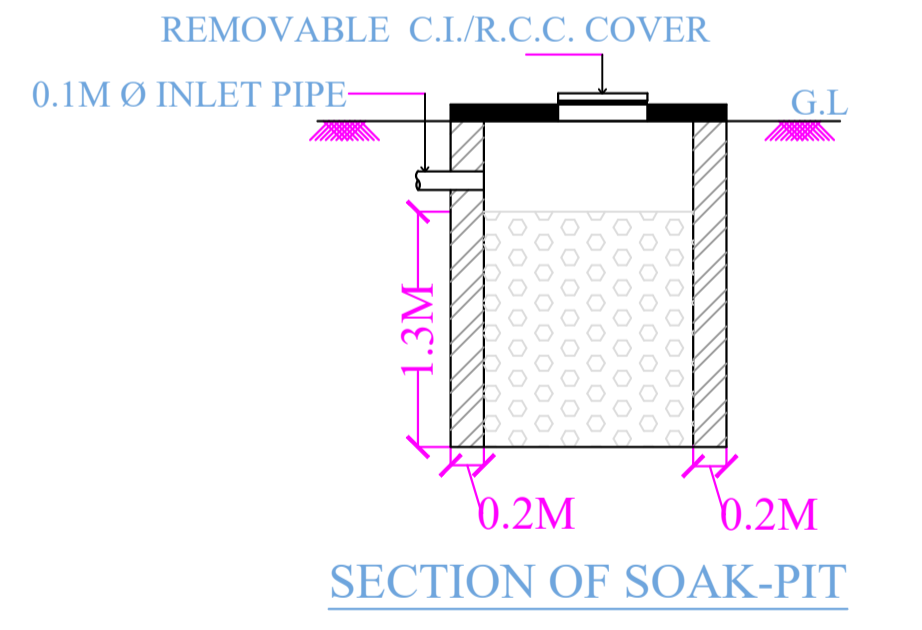

SECTION OF SOAK-PIT

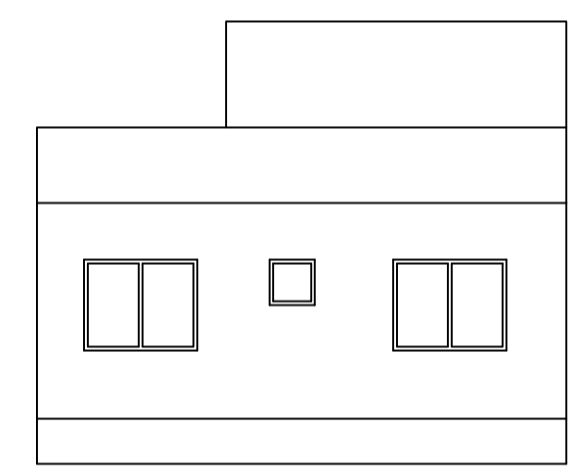
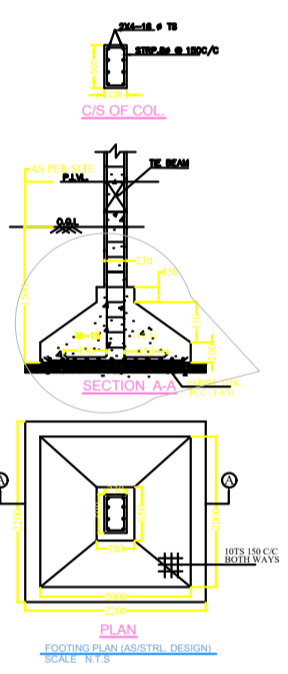

SIDE ELEVATION
SCALE:-1:100

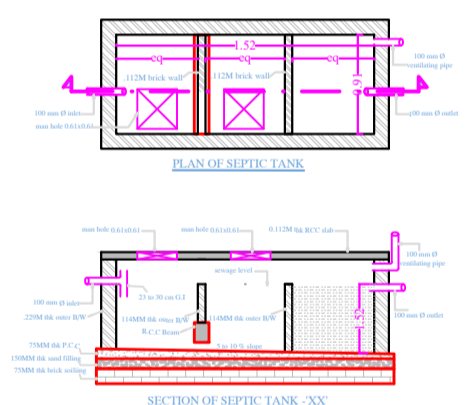

BLANK WATER TANK

UnitBUA Table for Building :AA (VITIKANT RAUT)

FLOOR	Name	UnitBUA Type	UnitBUA Area	Carpet Area	No. of Rooms	No. of Tenement
GROUND FLOOR PLAN	SPLIT FLAT A	FLAT	44.69	42.25	5	1
Total:	-	-	44.69	42.25	5	1

FAR & Tenement Details (Table 4c-1)

Building	No. of Same Bldg	Total Built Up Area (Sq.mt.)	Proposed FAR Area (Sq.mt.)	Total FAR Area (Sq.mt.)	Total Consumed Additional FAR Area (Sq.mt.)	Tnmt (No.)
AA (VITIKANT RAUT)	1	60.95	60.95	60.95	60.95	01
Grand Total :	1	60.95	60.95	60.95	60.95	01

COLOR INDEX

PLOT BOUNDARY	
ABUTTING ROAD	
PROPOSED CONSTRUCTION	
COMMON PLOT	
ROAD WIDENING AREA	
EXISTING (To be retained)	
EXISTING (To be demolished)	

LTP NAME AND SIGNATURE	STRUCTURAL ENG'S NAME AND SIGNATURE	BUILDER NAME AND SIGNATURE	DIGITAL SIGNATURE
KUNAL GUIN CNP/ENG/0006/2017			

AREA STATEMENT	VERSION NO.:	1.0.61
CHAIABASA NAGAR PARISHAD	VERSION DATE:	16/10/2020
PROJECT DETAIL:	Region:	JHARKHAND URBAN LOCAL BODIES
District:	Plot Use:	Residential
Authority:	Plot SubUse:	Bungalow/ Dwelling / Non Apartment
Imward_No:	Plot/Plot No.:	282 D
Application Type:	North: Plot No.:	- SAME PORTION OF THE PLOT
Project Type:	South: Road Width:	3.65
Nature of Development:	East: Plot No.:	- SUB PLOT NO 282/E
Location of Development Area:	West: Plot No.:	281
AREA DETAILS:		SQ.MT.
AREA OF PLOT (Minimum)	(A)	102.10
NET AREA OF PLOT(Gross Plot Area - Deduction from Gross Plot area)	(A-Deductions)	102.10
Deduction for Balance Plot Area(from Gross Plot Area)		
Common Plot		13.89
Total		13.89
BALANCE AREA OF PLOT(Net Plot Area - Recreational/Amenity space)	(A-Deductions)	88.21
PLOT AREA FOR COVERAGE(Net Plot Area)	(A-Deductions)	102.10
Plot Area for FAR (Net Plot Area + Road/Widening Area)	(A-Deductions)	102.10
COVERAGE CHECK		
Permissible Coverage area (70.00 %)		71.47
Proposed Coverage Area (59.70 %)		60.95
Total Prop. Coverage Area (59.7 %)		60.95
Balance coverage area (10.30 %)		10.52
FAR CHECK		
Perm. FAR Area (1.50)		153.15
Total Perm. FAR area		153.15
Residential FAR		60.95
Proposed FAR Area		60.95
Total Proposed FAR Area		60.95
Consumed FAR (Factor)		0.60
Balance FAR Area		92.20
BUILT UP AREA CHECK		
Total Proposed BuiltUp Area		60.95
ARCHITECT (Regd)		KUNAL GUIN
ENGINEER (Regd)		
SUPERVISOR (Regd)		
OWNER (Regd)		VITIKANT RAUT
DEVELOPMENT AUTHORITY		LOCAL BODY

SCHEDULE OF DOOR:

BUILDING NAME	NAME	LENGTH	HEIGHT	NOS
AA (VITIKANT RAUT)	D2	0.75	2.10	01
AA (VITIKANT RAUT)	D	1.00	2.10	01
AA (VITIKANT RAUT)	D1	1.00	2.13	01
AA (VITIKANT RAUT)	D	1.00	2.13	01
AA (VITIKANT RAUT)	D	1.13	2.10	01

SCHEDULE OF WINDOW/VENTILATION:

BUILDING NAME	NAME	LENGTH	HEIGHT	NOS
AA (VITIKANT RAUT)	V	0.60	1.20	01
AA (VITIKANT RAUT)	W	1.50	1.20	06

Building :AA (VITIKANT RAUT)

Floor Name	Total Built Up Area (Sq.mt.)	Proposed FAR Area (Sq.mt.)	Total FAR Area (Sq.mt.)	Total Consumed Additional FAR Area (Sq.mt.)	Tnmt (No.)
Ground Floor	60.95	60.95	60.95	60.95	01
Terrace Floor	0.00	0.00	0.00	0.00	00
Total :	60.95	60.95	60.95	60.95	01
Total Number of Same Buildings :	1				
Total :	60.95	60.95	60.95	60.95	01

Buildingwise Floor FAR Details

Floor Name	Building Name		Total	
	Proposed Built Up Area (Sq.mt.)	Proposed FAR Area (Sq.mt.)	Total Proposed Built Up Area (Sq.mt.)	Total FAR Area (Sq.mt.)
Ground Floor	60.95	60.95	60.95	60.95
Terrace Floor	0.00	0.00	0.00	0.00
Total :	60.95	60.95	60.95	60.95

Building USE/SUBUSE Details

Building Name	Building Use	Building SubUse	Building Structure
AA (VITIKANT RAUT)	Residential	Bungalow/ Dwelling / Non Apartment	Non-Highrise