

SITE PLAN
SCALE:-1:100

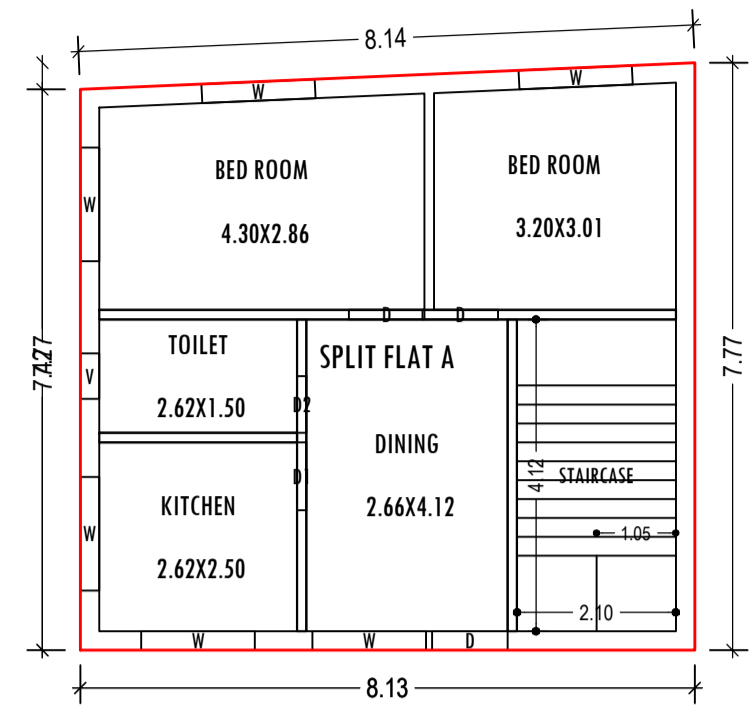

GROUND FLOOR PLAN
(Proposed)
SCALE 1:100

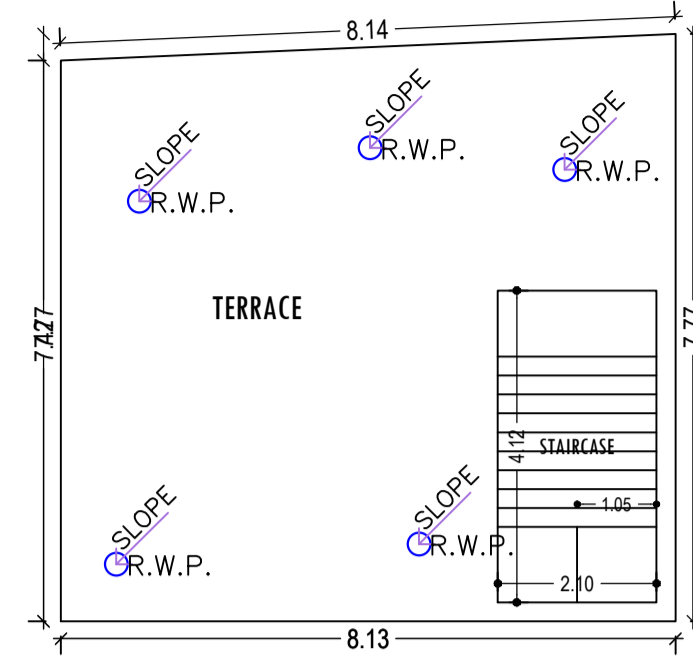

TERRACE FLOOR PLAN
(SCALE 1:100)

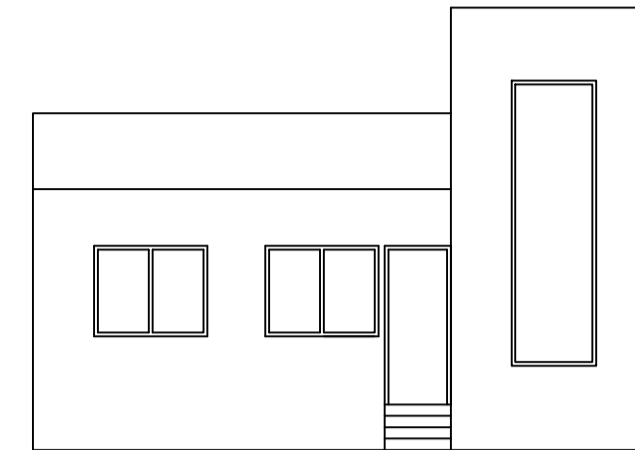

FRONT ELEVATION
SCALE:-1:100

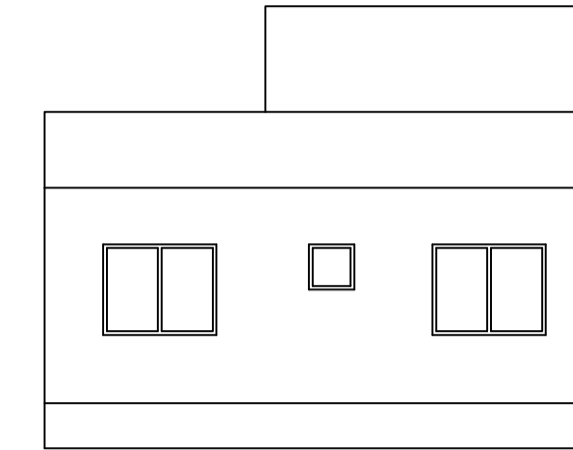

SIDE ELEVATION
SCALE:-1:100

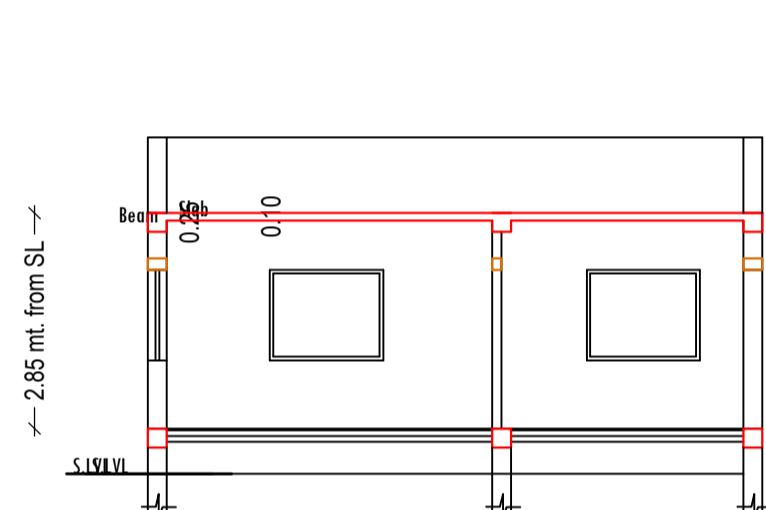

SECTION:- X,X
SCALE:-1:100

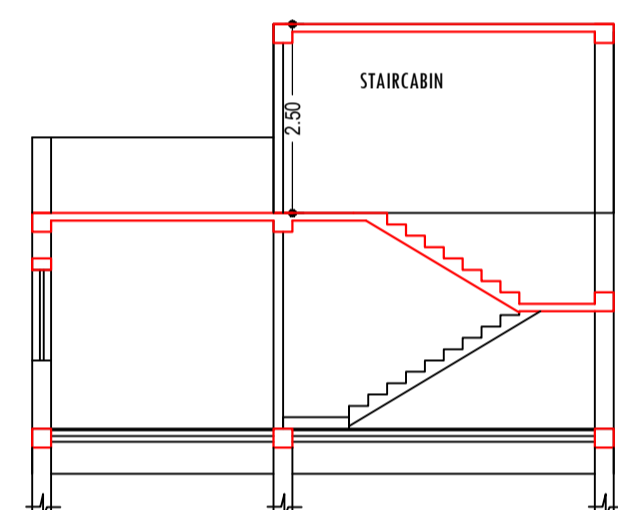

SECTION:- Y,Y
SCALE:-1:100

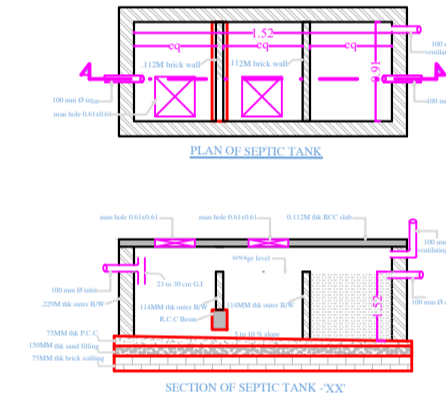
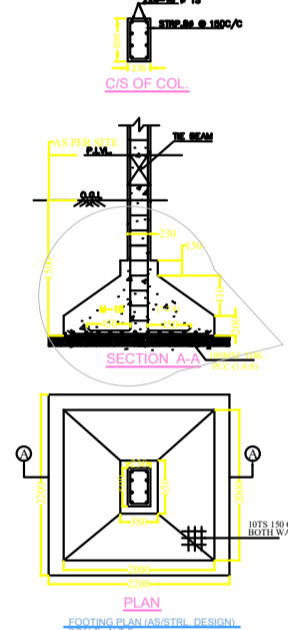

SITE PLAN

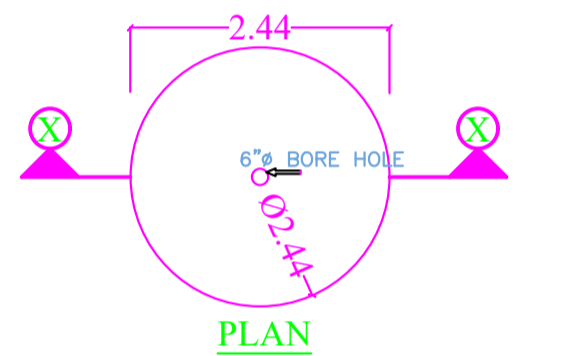

PLAN

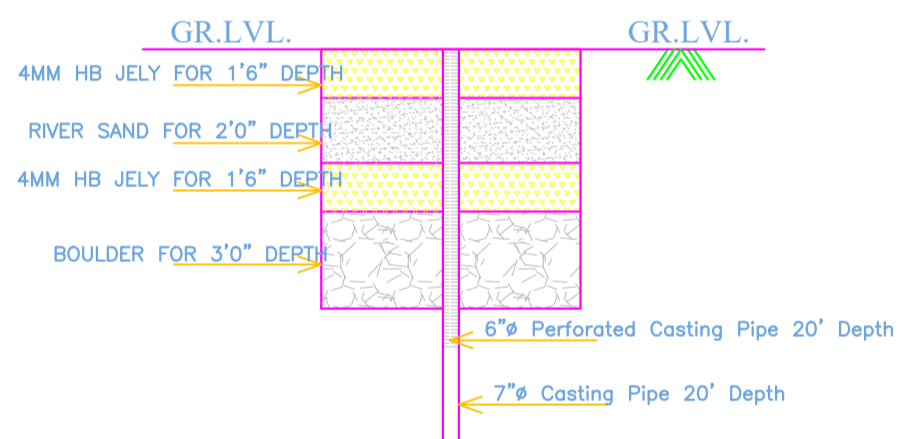

SECTION AT "X-X"

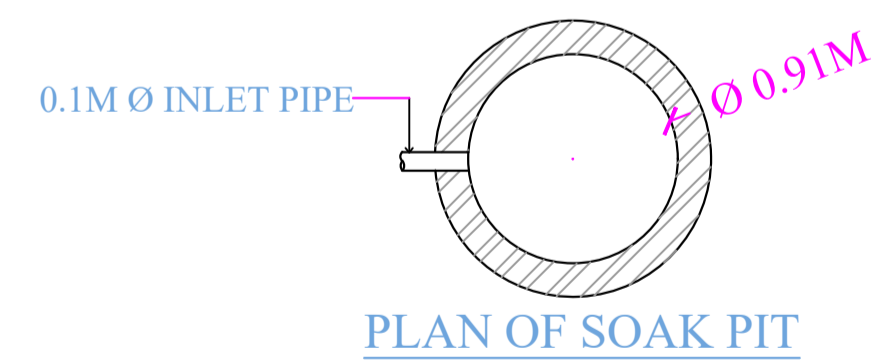

PLAN OF SOAK PIT

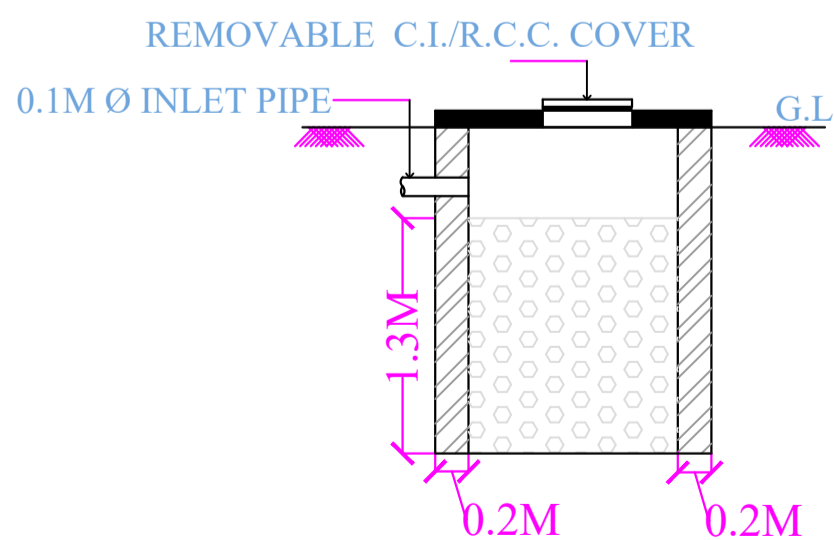

SECTION OF SOAK-PIT

Proposal Basic Information

Proposal File No.	CNP/BB/0003/W01/2022
Owner Name	GAUTAM MISHRA
Khata No	10
Plot No	282 E
Village Name	Pulhatu
Use	Residential
SubUse	Bungalow/ Dwelling / Non Apartment

AREA STATEMENT CHAIBASA NAGAR PARISHAD	VERSION NO.: 1.0.61 VERSION DATE: 16/10/2020
PROJECT DETAIL:	
Region: JHARKHAND URBAN LOCAL BODIES	Plot Use: Residential
District: WEST SINGBHUM	Plot SubUse: Bungalow/ Dwelling / Non Apartment
Authority: CHAIBASA NAGAR PARISHAD	PlotNearby/ReligiousStructure: NA
Inward_No: CNP/BB/0003/W01/2022	Plot/SubPlot No: 282 E
Application Type: General Proposal	North: Plot No. - SAME PORTION OF THE PLOT
Project Type: Building Permission	South: Road Width - 3.65
Nature of Development: New	East: Road Width - 3.65
Location of Development Area: Old Area	West: Plot No. - SUB PLOT NO. 282/D
AREA DETAILS:	SQ.MT.
AREA OF PLOT (Minimum)	(A) 99.96
NET AREA OF PLOT(Gross Plot Area - Deduction from Gross Plot area)	(A-Deductions) 99.96
Deduction for Balance Plot Area(from Gross Plot Area)	
Common Plot	17.62
Total	17.62
BALANCE AREA OF PLOT(Net Plot Area - Recreational/Amenity space)	(A-Deductions) 82.34
PLOT AREA FOR COVERAGE(Net Plot Area)	(A-Deductions) 99.96
Plot Area for FAR (Net Plot Area + RoadWidening Area)	(A-Deductions) 99.96
COVERAGE CHECK	
Permissible Coverage area (70.00 %)	69.97
Proposed Coverage Area (61.74 %)	61.72
Total Prop. Coverage Area (61.74 %)	61.72
Balance coverage area (8.25 %)	8.25
FAR CHECK	
Perm. FAR Area (1.50)	149.94
Total Perm. FAR area	149.94
Residential FAR	61.72
Proposed FAR Area	61.72
Total Proposed FAR Area	61.72
Consumed FAR (Factor)	0.62
Balance FAR Area	88.22
BUILT UP AREA CHECK	
Total Proposed BuiltUp Area	61.72
ARCHITECT (Regd)	KUNAL GUIN
ENGINEER (Regd)	
SUPERVISOR (Regd)	
OWNER (Regd)	GAUTAM MISHRA
DEVELOPMENT AUTHORITY LOCAL BODY	

SCHEDULE OF DOOR:

BUILDING NAME	NAME	LENGTH	HEIGHT	NOS
AA (GAUTAM MISHRA)	D2	0.75	2.13	01
AA (GAUTAM MISHRA)	D1	0.90	2.13	01
AA (GAUTAM MISHRA)	D	1.00	2.13	03

SCHEDULE OF WINDOW/VENTILATION:

BUILDING NAME	NAME	LENGTH	HEIGHT	NOS
AA (GAUTAM MISHRA)	V	0.60	0.60	01
AA (GAUTAM MISHRA)	W	1.50	1.20	06

Building :AA (GAUTAM MISHRA)

Floor Name	Total Built Up Area (Sq.mt.)	Proposed FAR Area (Sq.mt.) Resi.	Total FAR Area (Sq.mt.)	Total Consumed Additional FAR Area (Sq.mt.)	Trmt (No.)
Ground Floor	61.72	61.72	61.72	61.72	01
Terrace Floor	0.00	0.00	0.00	0.00	00
Total :	61.72	61.72	61.72	61.72	01
Total Number of Same Buildings :	1				
Total :	61.72	61.72	61.72	61.72	01

Buildingwise Floor FAR Details

Floor Name	Building Name AA (GAUTAM MISHRA)		Total	
	Proposed Built Up Area (Sq.mt.)	Proposed FAR Area (Sq.mt.)	Total Proposed Built Up Area (Sq.mt.)	Total FAR Area (Sq.mt.)
Ground Floor	61.72	61.72	61.72	61.72
Terrace Floor	0.00	0.00	0.00	0.00
Total :	61.72	61.72	61.72	61.72

Building USE/SUBUSE Details

Building Name	Building Use	Building SubUse	Building Structure
AA (GAUTAM MISHRA)	Residential	Bungalow/ Dwelling / Non Apartment	Non-Highrise

UnitBUA Table for Building :AA (GAUTAM MISHRA)

FLOOR	Name	UnitBUA Type	UnitBUA Area	Carpet Area	No. of Rooms	No. of Tenement
GROUND FLOOR PLAN	SPLIT FLAT A	FLAT	45.44	43.13	5	1
Total:	-	-	45.44	43.13	5	1

FAR & Tenement Details (Table 4c-1)

Building	No. of Same Bldg	Total Built Up Area (Sq.mt.)	Proposed FAR Area (Sq.mt.) Resi.	Total FAR Area (Sq.mt.)	Total Consumed Additional FAR Area (Sq.mt.)	Trmt (No.)
AA (GAUTAM MISHRA)	1	61.72	61.72	61.72	61.72	01
Grand Total :	1	61.72	61.72	61.72	61.72	01

COLOR INDEX

PLOT BOUNDARY	Black
ABUTTING ROAD	Green
PROPOSED CONSTRUCTION	Red
COMMON PLOT	Yellow
ROAD WIDENING AREA	Blue
EXISTING (To be retained)	Orange
EXISTING (To be demolished)	Light Blue

LTP NAME AND SIGNATURE

KUNAL GUIN
CNP/ENG/0006/2017

STRUCTURAL ENG'S NAME AND SIGNATURE

BUILDER NAME AND SIGNATURE

DIGITAL SIGNATURE