

GROUND FLOOR PLAN (Proposed) (SCALE 1:100)

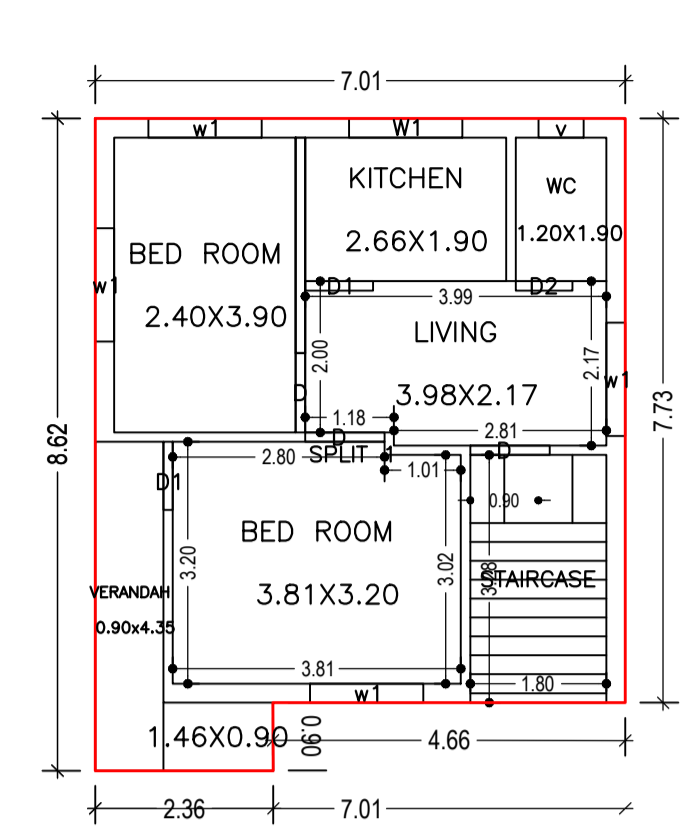

TYPICAL - 1 & 2 FLOOR PLAN (Proposed) (SCALE 1:100)

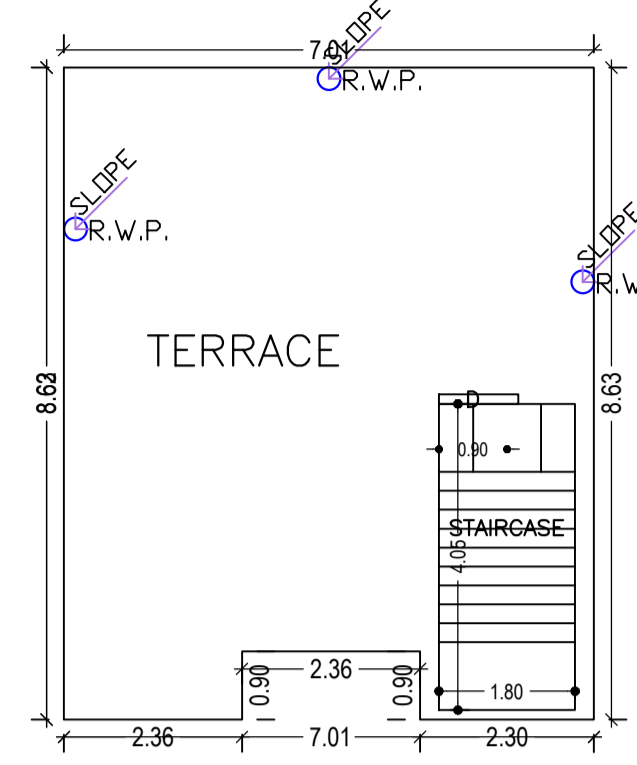

TERRACE FLOOR PLAN (SCALE 1:100)

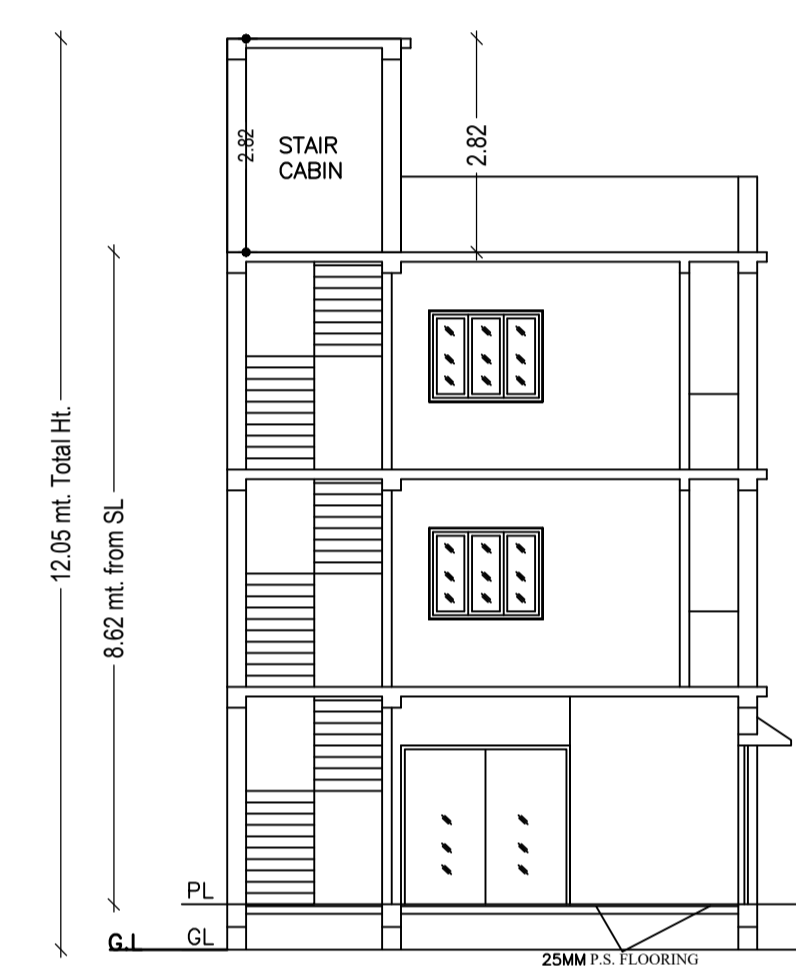

SECTION-XX SCALE- 1:100

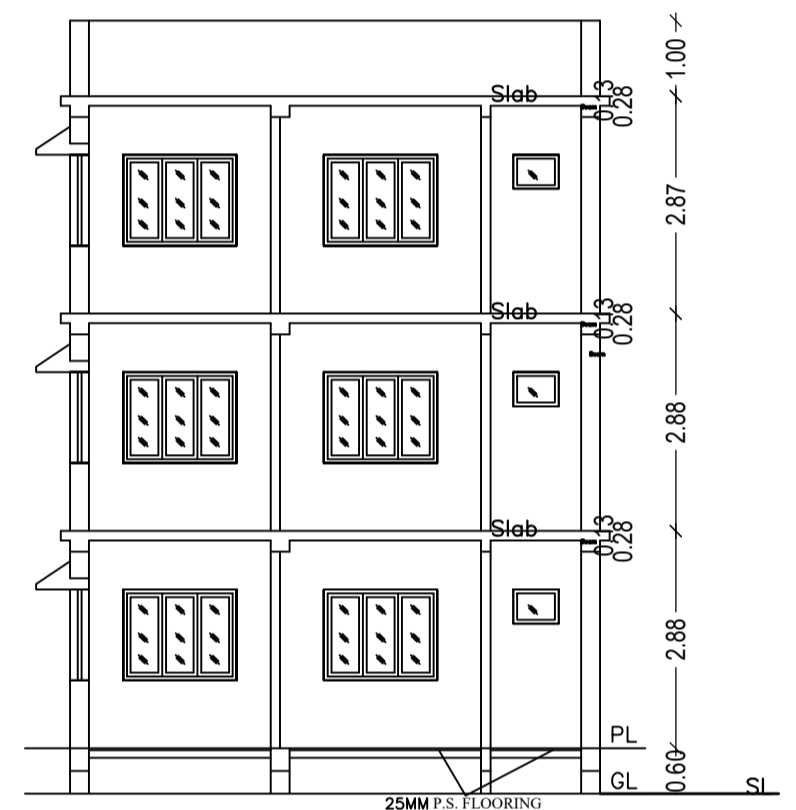

SECTION-YY SCALE- 1:100

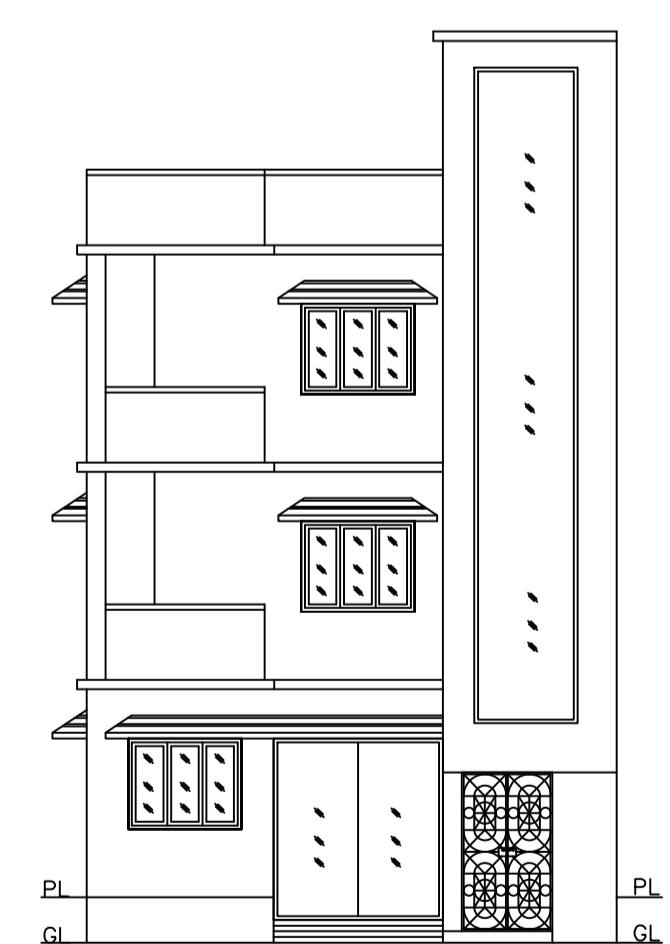

FRONT ELEVATION SCALE- 1:100

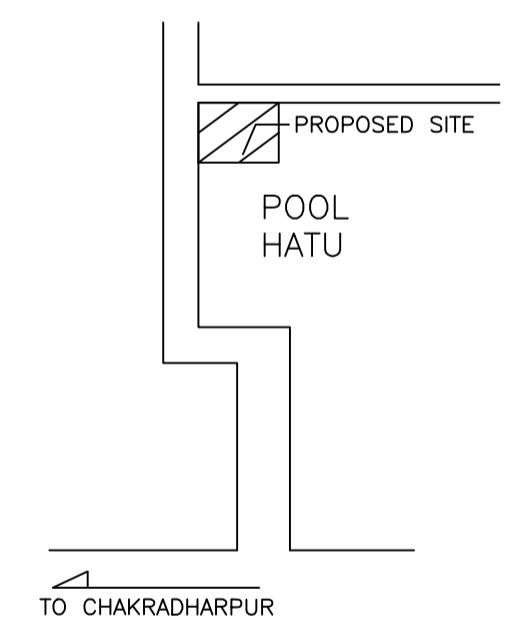

LOCATION PLAN SCALE: Not to scale

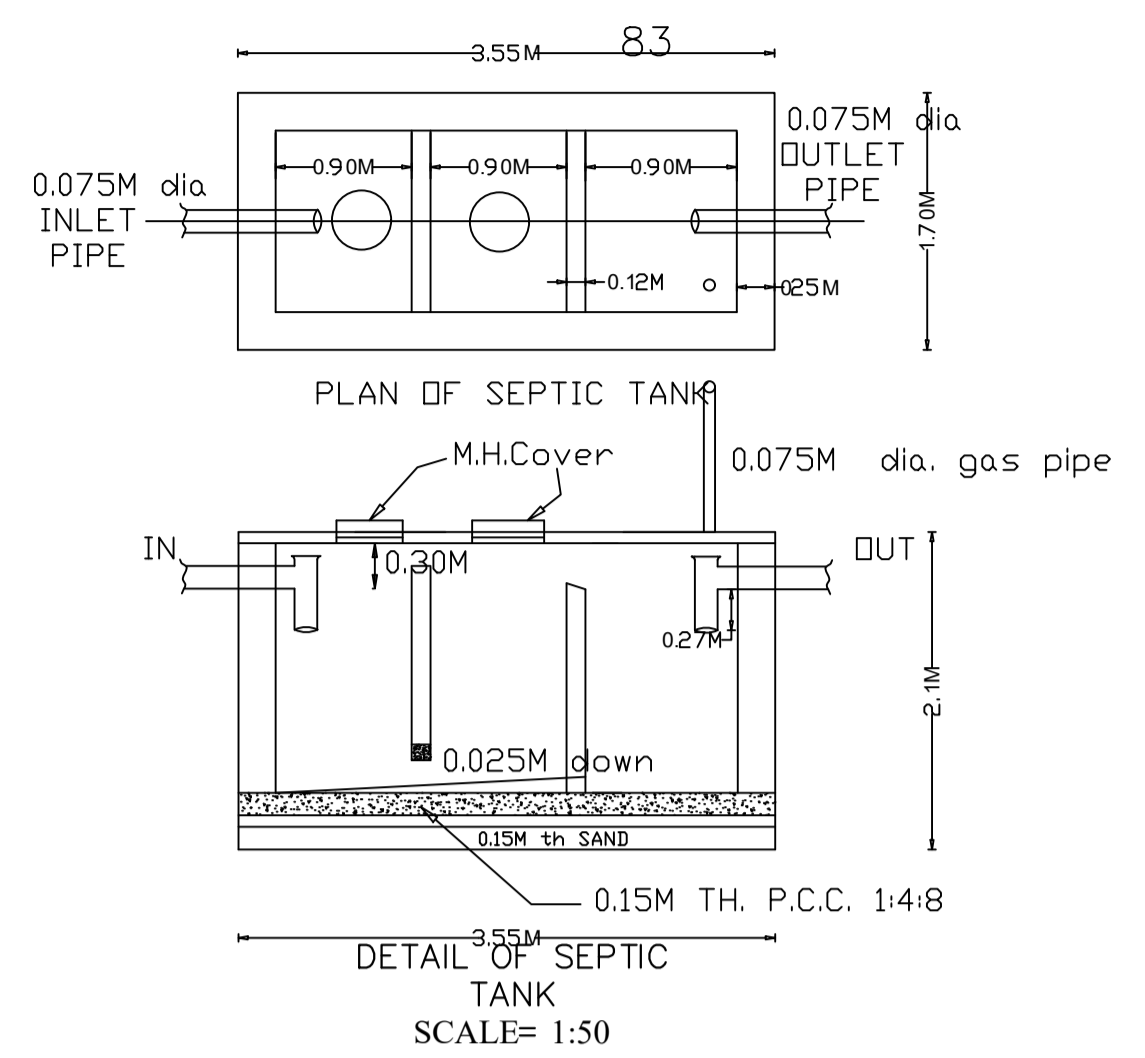

DETAIL OF SEPTIC TANK SCALE= 1:50

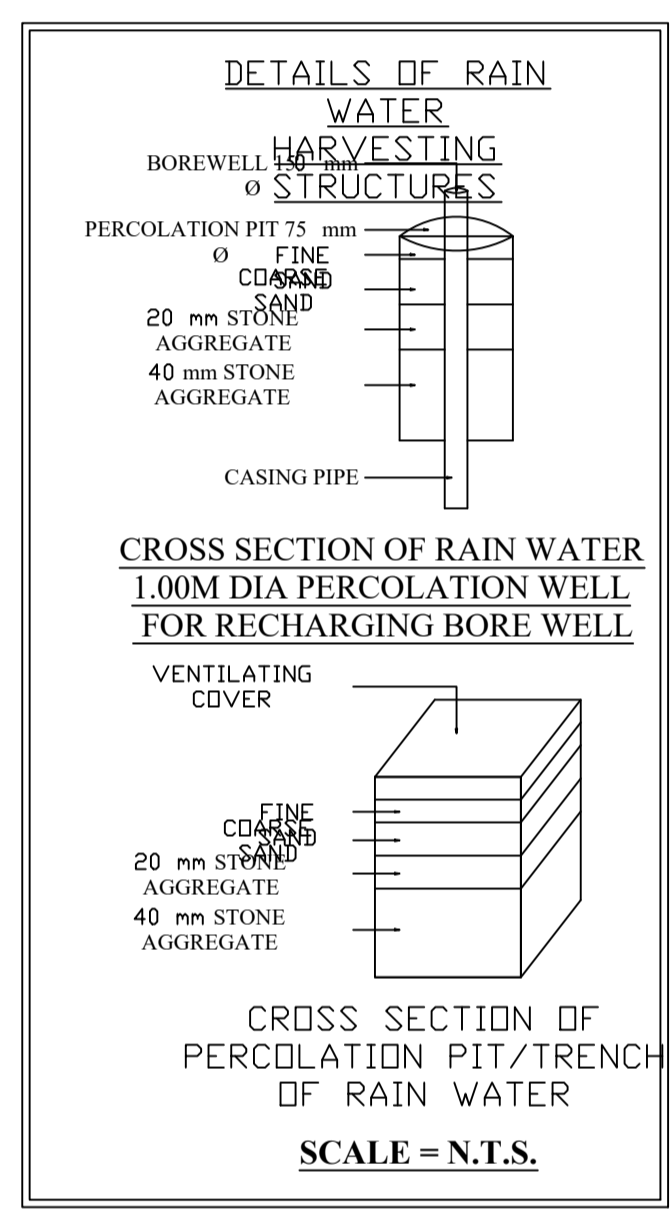

CROSS SECTION OF RAIN WATER 1.00M DIA PERCOLATION WELL FOR RECHARGING BORE WELL SCALE = N.T.S.

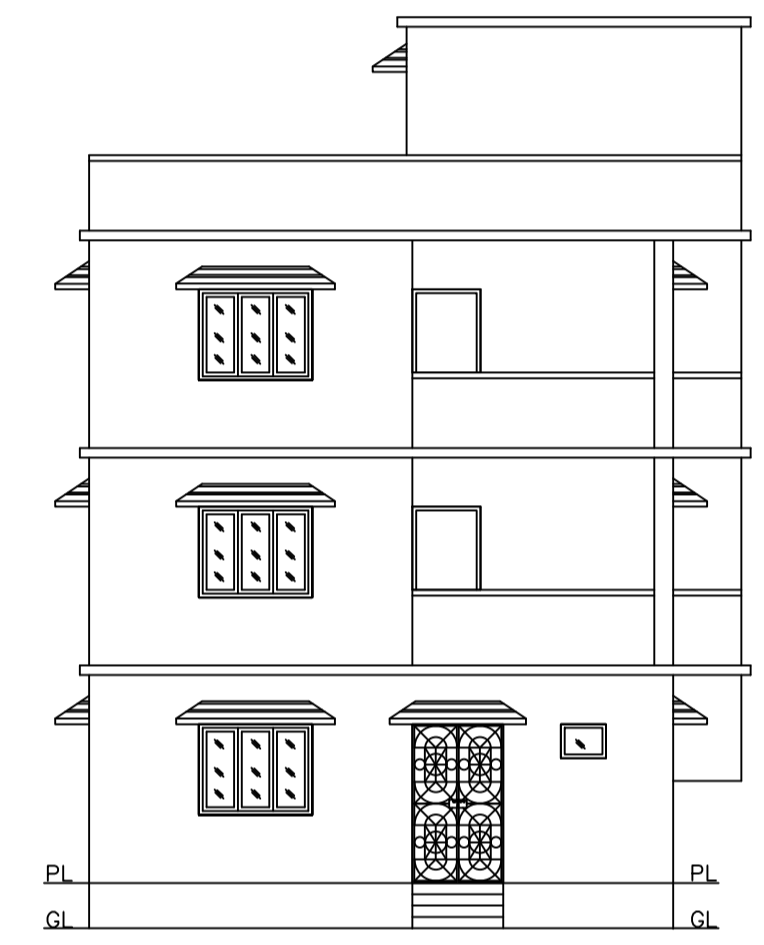

SIDE ELEVATION SCALE- 1:100

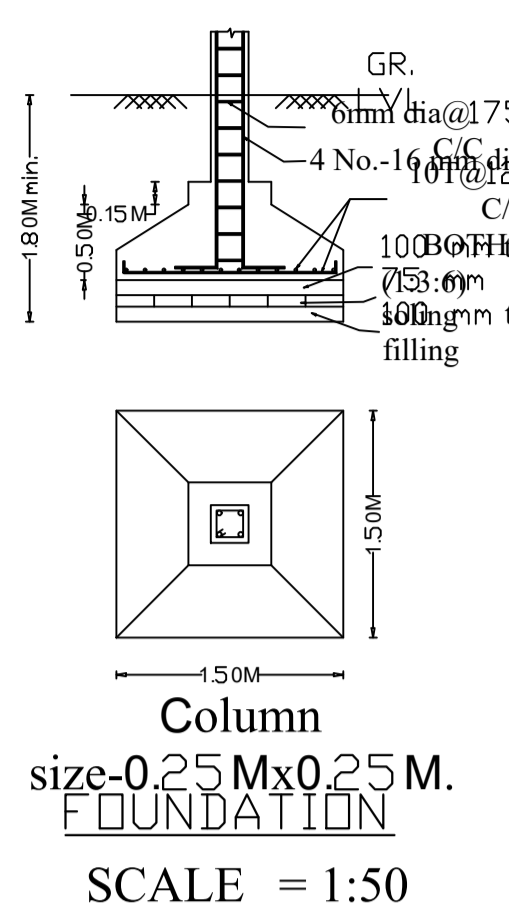

Column size-0.25Mx0.25M. FOUNDATION SCALE = 1:50

Proposal Basic Information	
Proposal File No.	CNP/BP/0026/W01/2022
Owner Name	MRS.RUNU PRADHAN
Khata No	35
Plot No	141
Village Name	Pulhatu
Use	Residential
SubUse	Bungalow/ Dwelling / Non Apartment

AREA STATEMENT		VERSION NO.: 1.0.64
CHAIBASA NAGAR PARSISHAD		VERSION DATE: 16/10/2020
PROJECT DETAIL:		
Region: JHARKHAND URBAN LOCAL BODIES	Plot Use: Residential	
District: WEST SINGHBHUM	Plot SubUse: Bungalow/ Dwelling / Non Apartment	
Authority: CHAIBASA NAGAR PARSISHAD	PlotNearbyReligiousStructure: NA	
Inward_No: CNP/BP/0026/W01/2022	Plot/SubPlot No: 141	
Application Type: General Proposal	North: Road Width - 6.20	
Project Type: Building Permission	South: Plot No. - SUB PLO NO-03	
Nature of Development: New	East: Plot No. - SUB PLO NO-2/A	
Location of Development Area: Old Area	West: Road Width - 6.5	
AREA DETAILS:		
AREA OF PLOT (Minimum)	(A)	SQ.MT. 94.91
NET AREA OF PLOT(Gross Plot Area - Deduction from Gross Plot area)	(A-Deductions)	94.91
Deduction for Balance Plot Area(from Gross Plot Area)		
Common Plot		13.87
Total		13.87
BALANCE AREA OF PLOT(Net Plot Area - Recreational/Amenity space)	(A-Deductions)	81.04
PLOT AREA FOR COVERAGE(Net Plot Area)	(A-Deductions)	94.91
Plot Area for FAR (Net Plot Area + RoadWidening Area)	(A-Deductions)	94.91
COVERAGE CHECK		
Permissible Coverage area (70.00 %)		66.44
Proposed Coverage Area (57.06 %)		54.16
Total Prop. Coverage Area (57.06 %)		54.16
Balance coverage area (12.94 %)		12.28
FAR CHECK		
Perm. FAR Area (2,000)		189.82
Total Perm. FAR area		189.82
Residential FAR		158.75
Proposed FAR Area		158.75
Total Proposed FAR Area		158.75
Consumed FAR (Factor)		1.67
Balance FAR Area		31.07
BUILT UP AREA CHECK		
Total Proposed BuiltUp Area		166.72
ARCHITECT (Regd)	SAQUIB JAWED	
ENGINEER (Regd)		
SUPERVISOR (Regd)		
OWNER (Regd)	MRS.RUNU PRADHAN	
DEVELOPMENT AUTHORITY		LOCAL BODY

Floor Name	Total Built Up Area (Sq.mt.)	Deductions (Area in Sq.mt.)	Proposed FAR Area (Sq.mt.)	Total FAR Area (Sq.mt.)	Total Consumed Additional FAR Area (Sq.mt.)	Trmt (No.)
Ground Floor	54.16	7.97	46.19	46.19	46.19	01
First Floor	56.28	0.00	56.28	56.28	56.28	00
Second Floor	56.28	0.00	56.28	56.28	56.28	00
Terrace Floor	0.00	0.00	0.00	0.00	0.00	00
Total :	166.72	7.97	158.75	158.75	158.75	01
Total Number of Same Buildings :	1					
Total :	166.72	7.97	158.75	158.75	158.75	01

SCHEDULE OF DOOR:

BUILDING NAME	NAME	LENGTH	HEIGHT	NOS
A (RESIDENTIAL)	D2	0.75	2.10	03
A (RESIDENTIAL)	D1	0.90	2.10	06
A (RESIDENTIAL)	D	1.05	2.10	08
A (RESIDENTIAL)	G	1.20	2.10	01

SCHEDULE OF WINDOW/VENTILATION:

BUILDING NAME	NAME	LENGTH	HEIGHT	NOS
A (RESIDENTIAL)	v	0.60	1.20	04
A (RESIDENTIAL)	w1	1.50	1.20	12
A (RESIDENTIAL)	w1	1.50	1.20	03

FAR & Tenement Details (Table 4c-1)

Building	No. of Same Bldg	Total Built Up Area (Sq.mt.)	Deductions (Area in Sq.mt.)	Proposed FAR Area (Sq.mt.)	Total FAR Area (Sq.mt.)	Total Consumed Additional FAR Area (Sq.mt.)	Trmt (No.)
A (RESIDENTIAL)	1	166.72	7.97	158.75	158.75	158.75	01
Grand Total :	1	166.72	7.97	158.75	158.75	158.75	01

Building USE/SUBUSE Details

Building Name	Building Use	Building SubUse	Building Structure
A (RESIDENTIAL)	Residential	Bungalow/ Dwelling / Non Apartment	Non-Highrise

Buildingwise Floor FAR Details

Floor Name	Building Name A (RESIDENTIAL)		Total	
	Proposed Built Up Area (Sq.mt.)	Proposed FAR Area (Sq.mt.)	Total Proposed Built Up Area (Sq.mt.)	Total FAR Area (Sq.mt.)
Ground Floor	54.16	46.19	54.16	46.19
First Floor	56.28	56.28	56.28	56.28
Second Floor	56.28	56.28	56.28	56.28
Terrace Floor	0.00	0.00	0.00	0.00
Total :	166.72	158.75	166.72	158.75

UnitBUA Table for Building :A (RESIDENTIAL)

FLOOR	Name	UnitBUA Type	UnitBUA Area	Carpet Area	No. of Rooms	No. of Tenement
GROUND FLOOR PLAN	SPLIT 1	FLAT	121.82	120.76	6	1
TYPICAL - 1 & 2 FLOOR PLAN	SPLIT 1	FLAT	0.00	0.00	6	0
Total:	-	-	121.82	120.76	18	1

COLOR INDEX

PLOT BOUNDARY	[Red Line]
ABUTTING ROAD	[Green Line]
PROPOSED CONSTRUCTION	[Blue Line]
COMMON PLOT	[Orange Line]
ROAD WIDENING AREA	[Yellow Line]
EXISTING (To be retained)	[Grey Line]
EXISTING (To be demolished)	[White Line]

LTP NAME AND SIGNATURE: SAQUIB JAWED, CNP/ENG/0007/2021

STRUCTURAL ENG'S NAME AND SIGNATURE: [Blank]

BUILDER NAME AND SIGNATURE: [Blank]

DIGITAL SIGNATURE: [Blank]