

**Proposal Basic Information**

Proposal File No.	CNP/EP/0017/W/18/2023
Owner Name	MRS.MITHU MODI
Khata No	00
Plot No	128 A TO 128 M
Village Name	Amla Tola
Use	Residential
SubUse	Bungalow/ Dwelling / Non Apartment

**AREA STATEMENT**

CHAIBASA NAGAR PARISHAD

REGION: JHARKHAND URBAN LOCAL BODIES  
DISTRICT: WEST SINGBHMUM  
AUTHORITY: CHAIBASA NAGAR PARISHAD  
INWARD No: CNP/EP/0017/W/18/2023  
APPLICATION Type: General Proposal  
PROJECT Type: Building Permission  
NATURE OF DEVELOPMENT: New  
LOCATION OF DEVELOPMENT AREA: Old Area

VERSION NO.: 1.0.66  
VERSION DATE: 16/10/2020

AREA DETAILS:		SQ.MT.
AREA OF PLOT (Minimum)	(A)	111.48
NET AREA OF PLOT (Gross Plot Area - Deduction from Gross Plot area)	(A-Deductions)	111.48
Deduction for Balance Plot Area (from Gross Plot Area)		
Common Plot		13.89
Total		13.89
BALANCE AREA OF PLOT (Net Plot Area - Recreational/Amenity space)	(A-Deductions)	97.59
PLOT AREA FOR COVERAGE (Net Plot Area)	(A-Deductions)	111.48
Plot Area for FAR (Net Plot Area + Road Widening Area)	(A-Deductions)	111.48
COVERAGE CHECK		
Permissible Coverage area ( 70.00 % )		78.04
Proposed Coverage Area ( 67.10 % )		74.80
Total Prop. Coverage Area ( 67.1 % )		74.80
Balance coverage area ( 2.91 % )		3.24
FAR CHECK		
Perm. FAR Area ( 2.000 )		222.96
Total Perm. FAR area		222.96
Residential FAR		217.94
Proposed FAR Area		217.94
Total Proposed FAR Area		217.94
Consumed FAR (Factor)		1.95
Balance FAR Area		5.02
BUILT UP AREA CHECK		
Total Proposed BuiltUp Area		282.81
ARCHITECT (Regd)		
ARCHITECT (Regd)		SAQUIB JAWED
ENGINEER (Regd)		
ENGINEER (Regd)		
SUPERVISOR (Regd)		
SUPERVISOR (Regd)		
OWNER (Regd)		
OWNER (Regd)		MRS.MITHU MODI
DEVELOPMENT AUTHORITY		
DEVELOPMENT AUTHORITY		LOCAL BODY

**COLOR INDEX**

PLOT BOUNDARY	Black
ABUTTING ROAD	Green
PROPOSED CONSTRUCTION	Red
COMMON PLOT	Yellow
ROAD WIDENING AREA	Blue
EXISTING (To be retained)	Light Blue
EXISTING (To be demolished)	Orange

**Buildingwise Floor FAR Details**

Floor Name	Building Name A (RESIDENTIAL)		Total	
	Proposed Built Up Area (Sq.mt.)	Proposed FAR Area (Sq.mt.)	Total Proposed Built Up Area (Sq.mt.)	Total FAR Area (Sq.mt.)
Ground Floor	74.80	74.80	74.80	74.80
First Floor	107.76	82.14	107.76	82.14
Second Floor	100.25	61.00	100.25	61.00
Terrace Floor	0.00	0.00	0.00	0.00
Total :	282.81	217.94	282.81	217.94

**Building USE/SUBUSE Details**

Building Name	Building Use	Building SubUse	Building Structure
A (RESIDENTIAL)	Residential	Bungalow/ Dwelling / Non Apartment	Non-Highrise

**FAR & Tenement Details (Table 4c-1)**

Building	No. of Same Bldg	Gross Built Up Area (Sq.mt.)	Deductions From Gross BUA/Area in Sq.mt.)		Total Built Up Area (Sq.mt.)	Deductions (Area in Sq.mt.)		Proposed FAR Area (Sq.mt.)	Total FAR Area (Sq.mt.)	Total Consumed Additional FAR Area (Sq.mt.)	Trmt (No.)
			Cutout	Void		Accessory Use	Resi.				
A (RESIDENTIAL)	1	290.32	7.51	282.81	6.34	58.53	217.94	217.94	217.94	01	
Grand Total	1	290.32	7.51	282.81	6.34	58.53	217.94	217.94	217.94	01	

LTP NAME AND SIGNATURE	STRUCTURAL ENG'S NAME AND SIGNATURE	BUILDER NAME AND SIGNATURE	DIGITAL SIGNATURE
SAQUIB JAWED CNP/ENG/0007/2021			

Proposal Basic Information	
Proposal File No.	CNP/EP/0017/W18/2023
Owner Name	MRS.MITHU MODI
Khata No	00
Plot No	128 A TO 128 M
Village Name	Amla Tola
Use	Residential
SubUse	Bungalow/ Dwelling / Non Apartment

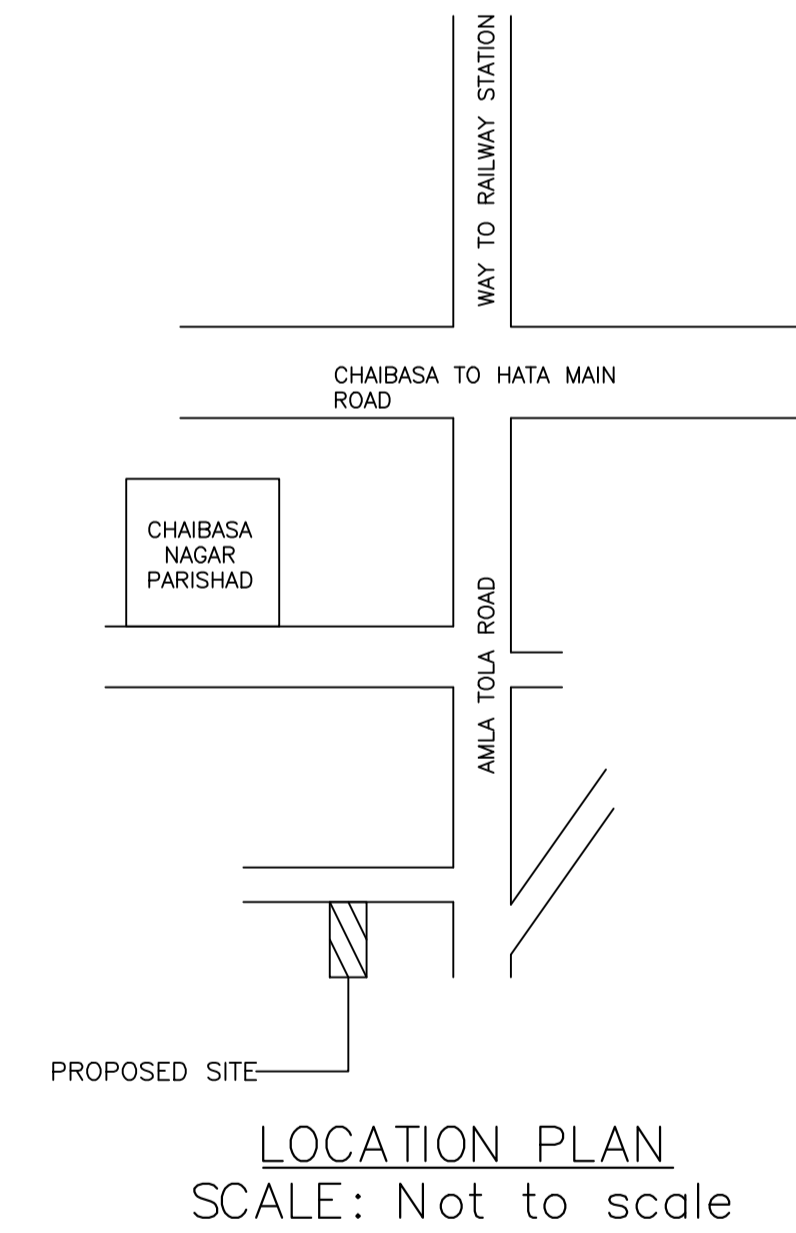
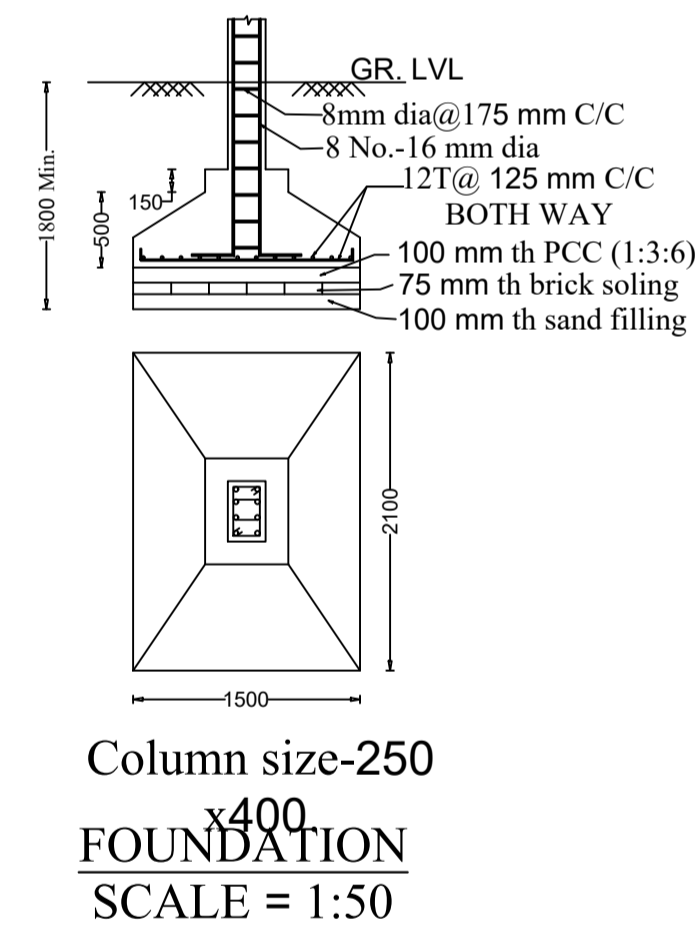
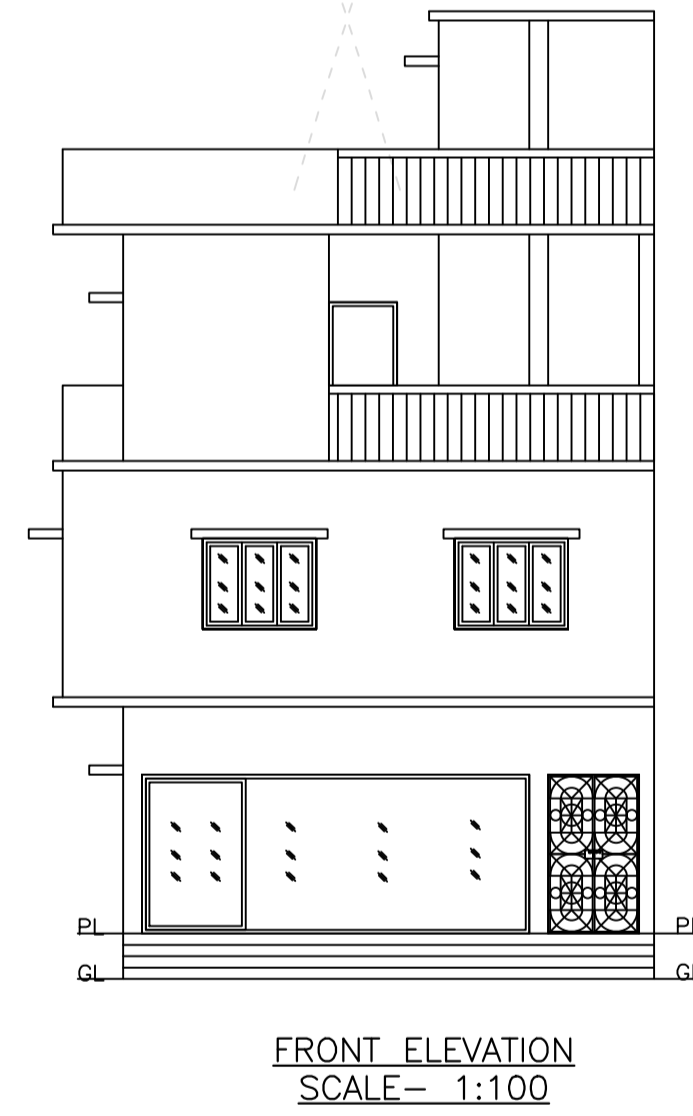
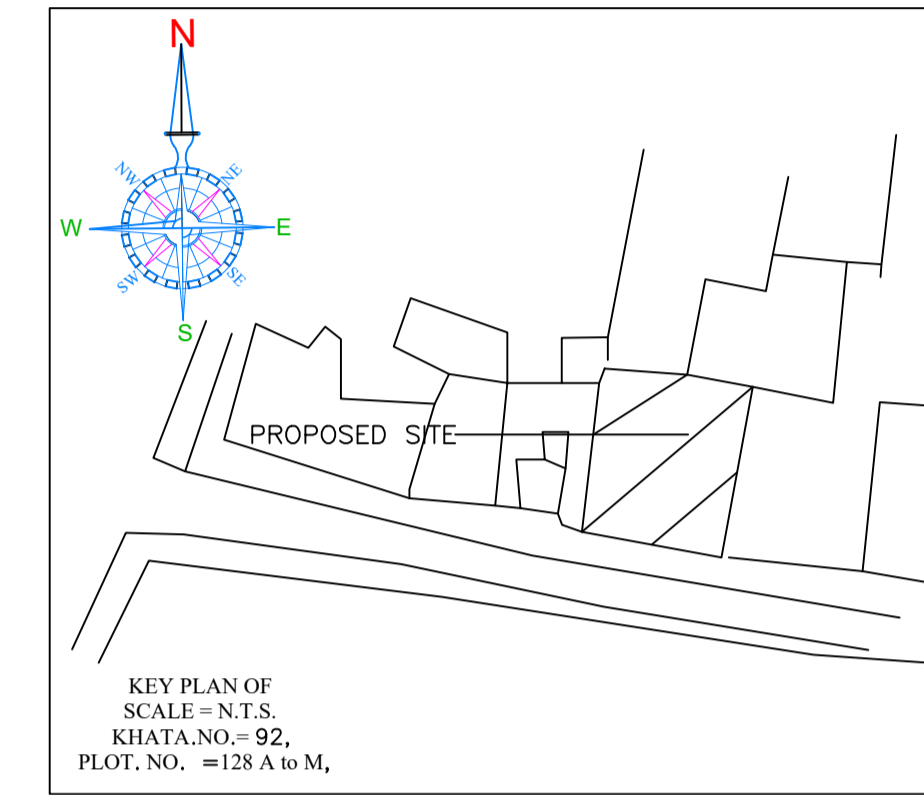
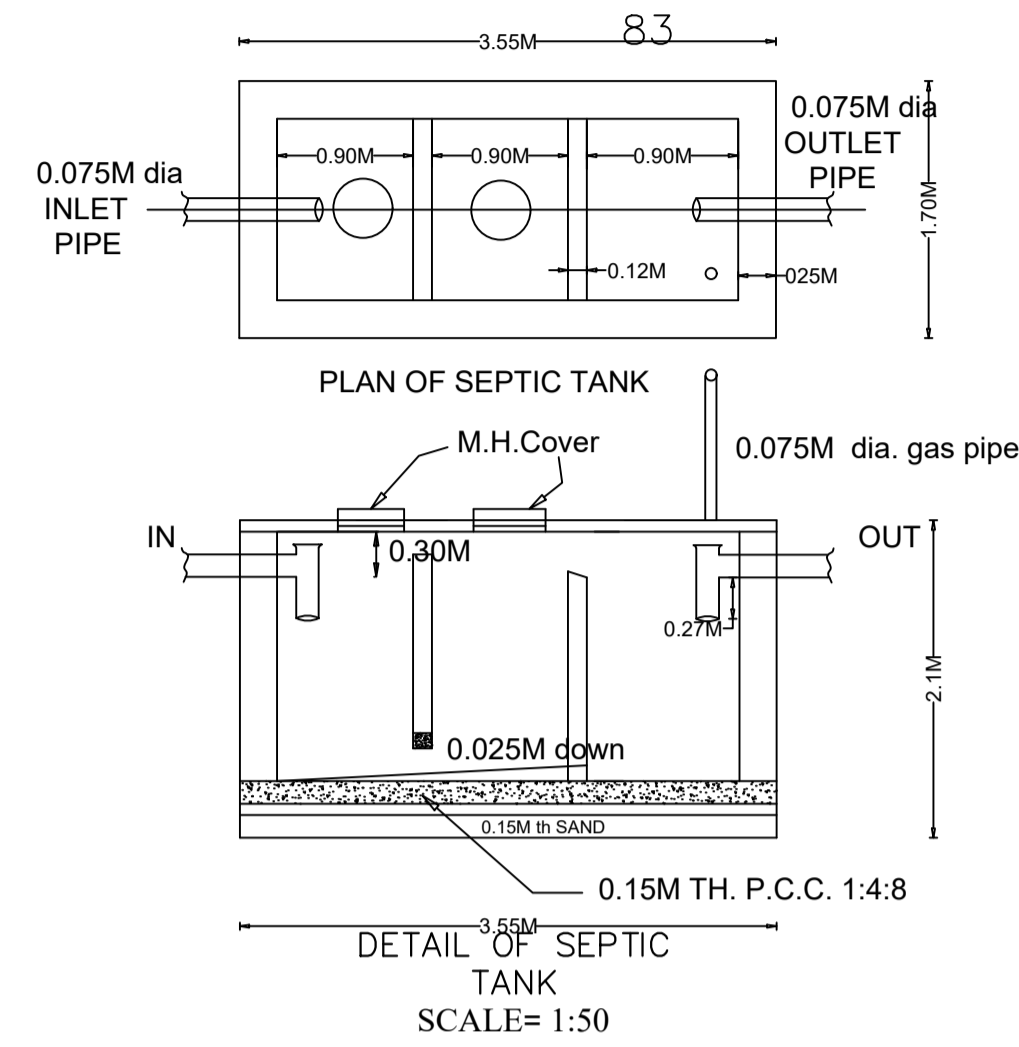
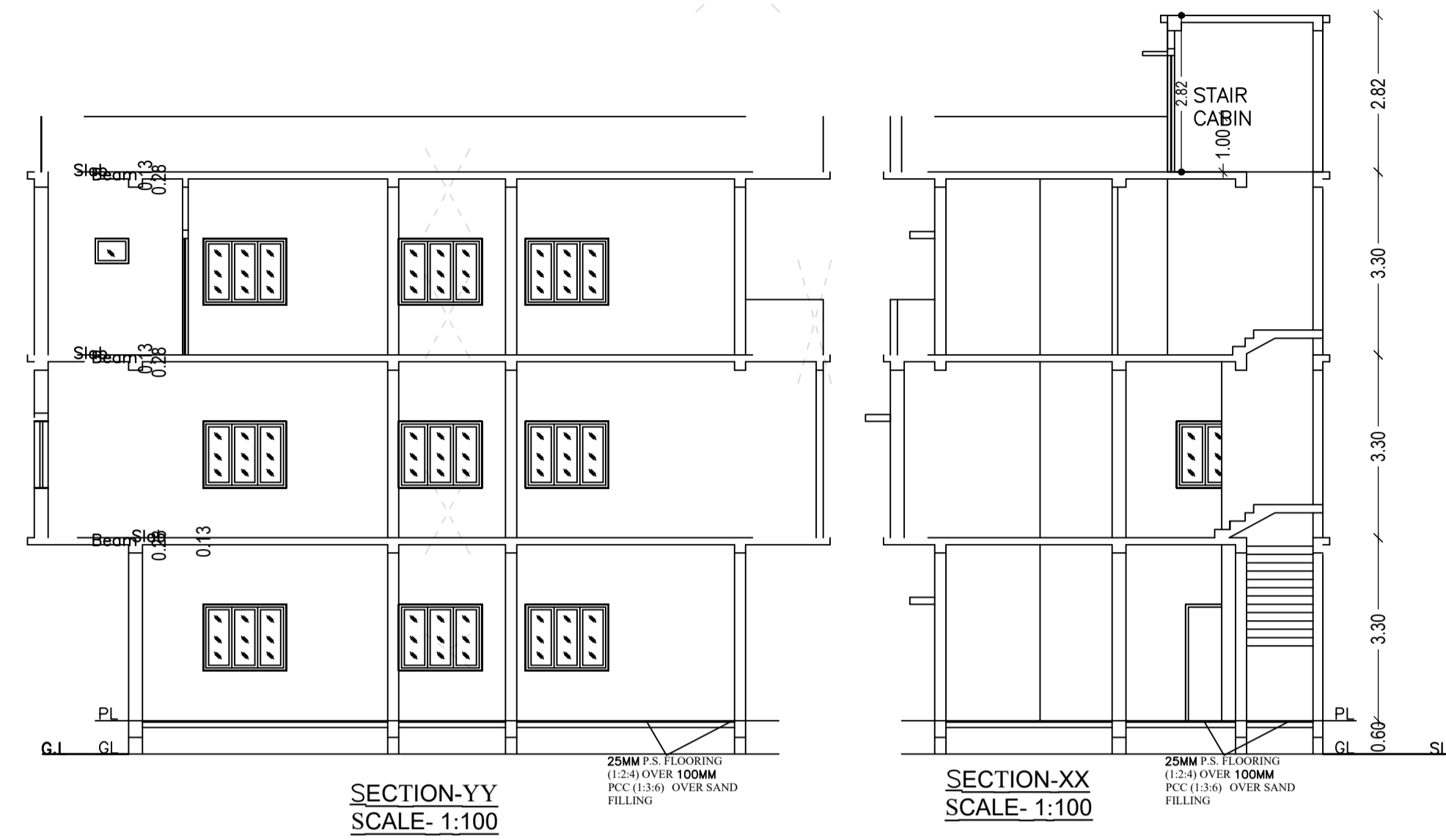

Building :A (RESIDENTIAL)

Floor Name	Gross Builtup Area (Sq.mt.)	Deductions From Gross BUA/Area in Sq.mt.)		Total Built Up Area (Sq.mt.)	Deductions (Area in Sq.mt.)		Proposed FAR Area (Sq.mt.)	Total FAR Area (Sq.mt.)	Total Consumed Additional FAR Area (Sq.mt.)	Tnmt (No.)
		Outout			Void	Accessory Use				
Ground Floor	74.80	0.00		74.80	0.00	0.00	74.80	74.80	74.80	01
First Floor	107.76	0.00		107.76	6.34	19.28	82.14	82.14	82.14	00
Second Floor	107.76	7.51		100.25	0.00	39.25	61.00	61.00	61.00	00
Terrace Floor	0.00	0.00		0.00	0.00	0.00	0.00	0.00	0.00	00
<b>Total :</b>	<b>290.32</b>	<b>7.51</b>		<b>282.81</b>	<b>6.34</b>	<b>58.53</b>	<b>217.94</b>	<b>217.94</b>	<b>217.94</b>	<b>01</b>
Total Number of Same Buildings :	1									
<b>Total :</b>	<b>290.32</b>	<b>7.51</b>		<b>282.81</b>	<b>6.34</b>	<b>58.53</b>	<b>217.94</b>	<b>217.94</b>	<b>217.94</b>	<b>01</b>

SCHEDULE OF DOOR:

BUILDING NAME	NAME	LENGTH	HEIGHT	NOS
A (RESIDENTIAL)	D2	0.75	2.10	02
A (RESIDENTIAL)	D1	0.84	2.10	01
A (RESIDENTIAL)	D	0.90	2.10	01
A (RESIDENTIAL)	D	0.98	2.10	02
A (RESIDENTIAL)	D	1.13	2.10	01
A (RESIDENTIAL)	MAIN ENTRANCE	4.82	2.10	01

SCHEDULE OF WINDOW/VENTILATION:

BUILDING NAME	NAME	LENGTH	HEIGHT	NOS
A (RESIDENTIAL)	V	0.60	1.20	02
A (RESIDENTIAL)	W1	1.50	1.20	11

UnitBUA Table for Building :A (RESIDENTIAL)

FLOOR	Name	UnitBUA Type	UnitBUA Area	Carpet Area	No. of Rooms	No. of Tenement
GROUND FLOOR PLAN	SPLIT 1	FLAT	201.82	201.61	1	1
FIRST FLOOR PLAN	SPLIT 1	FLAT	0.00	0.00	1	0
SECOND FLOOR PLAN	SPLIT 1	FLAT	0.00	0.00	6	0
<b>Total:</b>	-	-	<b>201.82</b>	<b>201.61</b>	<b>8</b>	<b>1</b>

LTP NAME AND SIGNATURE	STRUCTURAL ENG'S NAME AND SIGNATURE	BUILDER NAME AND SIGNATURE	DIGITAL SIGNATURE
SAQUIB JAWED CNP/ENG/0007/2021			