

A (RESIDENTIAL)  
BLDG HT: 12.00 MT.  
NO OF FLOORS: 4

Proposal Basic Information	
Proposal File No.	CNP/BI/0028/W18/2023
Owner Name	M/s MANGIL RUNGTA PARTNERSHIP FIRM. REPRESENTED BY ONE OF ITS PARTNER- MR.MUKUND RUNGTA
Khata No	00
Plot No	2905 (OLD), 199 (NEW)
Village Name	Amla Tola
Use	Residential
SubUse	Bungalow/ Dwelling / Non Apartment

AREA STATEMENT		VERSION NO. : 1.0.66
CHABASA NAGAR PARISHAD		VERSION DATE: 16/10/2020
PROJECT DETAIL:		
Region: JHARKHAND URBAN LOCAL BODIES	Plot Use: Residential	
District: WEST SINGHBHUM	Plot SubUse: Bungalow/ Dwelling / Non Apartment	
Authority: CHABASA NAGAR PARISHAD	PlotNearby/ReligiousStructure: NA	
Inward No: CNP/BI/0028/W18/2023	Plot/SubPlot No: 2905 (OLD), 199 (NEW)	
Application Type: General Proposal	North: Plot No. - JOGMAYA PRASAD	
Project Type: Building Permission	South: Plot No. - KHIRWAL	
Nature of Development: New	East: Plot No. - NALA	
Location of Development Area: Old Area	West: Road Width - 6.20	

AREA DETAILS:		SQ. MT.
AREA OF PLOT (Minimum)	(A)	262.30
NET AREA OF PLOT(Gross Plot Area - Deduction from Gross Plot area)	(A-Deductions)	262.30
Deduction for Balance Plot Area(from Gross Plot Area)		
Common Plot		52.17
Total		52.17
BALANCE AREA OF PLOT(Net Plot Area - Recreational/Amenity space)	(A-Deductions)	210.13
PLOT AREA FOR COVERAGE(Net Plot Area)	(A-Deductions)	262.30
Plot Area for FAR (Net Plot Area + Road Widening Area)	(A-Deductions)	262.30

COVERAGE CHECK		
Permissible Coverage area ( 60.00 % )		157.38
Proposed Coverage Area ( 29.49 % )		77.36
Total Prop. Coverage Area ( 29.49 % )		77.36
Balance coverage area ( 30.51 % )		80.02

FAR CHECK		
Perm. FAR Area ( 2.000 )		524.60
Total Perm. FAR area		524.60
Residential FAR		335.01
Proposed FAR Area		335.01
Total Proposed FAR Area		335.01
Consumed FAR (Factor)		1.28
Balance FAR Area		189.59

BUILT UP AREA CHECK	
Total Proposed BuiltUp Area	335.00
ARCHITECT (Regd)	SAQUIB JAWED
ENGINEER (Regd)	
SUPERVISOR (Regd)	
OWNER (Regd)	M/s MANGIL RUNGTA PARTNERSHIP FIRM. REPRESENTED BY ONE OF ITS PARTNER- MR.MUKUND RUNGTA
DEVELOPMENT AUTHORITY	LOCAL BODY

COLOR INDEX	
PLOT BOUNDARY	[Red Line]
ABUTTING ROAD	[Green Line]
PROPOSED CONSTRUCTION	[Blue Line]
COMMON PLOT	[Yellow Line]
ROAD WIDENING AREA	[Orange Line]
EXISTING (To be retained)	[Purple Line]
EXISTING (To be demolished)	[Pink Line]

Floor Name	Building Name		Total	
	Proposed Built Up Area (Sq.mt.)	Proposed FAR Area (Sq.mt.)	Total Proposed Built Up Area (Sq.mt.)	Total FAR Area (Sq.mt.)
Ground Floor	77.36	77.36	77.36	77.36
First Floor	85.88	85.88	85.88	85.88
Second Floor	85.88	85.88	85.88	85.88
Third Floor	85.88	85.88	85.88	85.88
Terrace Floor	0.00	0.00	0.00	0.00
<b>Total :</b>	<b>335.00</b>	<b>335.00</b>	<b>335.00</b>	<b>335.00</b>

Building USE/SUBUSE Details			
Building Name	Building Use	Building SubUse	Building Structure
A (RESIDENTIAL)	Residential	Bungalow/ Dwelling / Non Apartment	Non-Highrise

FAR & Tenement Details (Table 4c-1)

Building	No. of Same Bldg	Total Built Up Area (Sq.mt.)	Proposed FAR Area (Sq.mt.)	Total FAR Area (Sq.mt.)	Total Consumed Additional FAR Area (Sq.mt.)	Trmt (No.)
A (RESIDENTIAL)	1	335.00	335.00	335.00	335.00	01
<b>Grand Total :</b>	<b>1</b>	<b>335.00</b>	<b>335.00</b>	<b>335.00</b>	<b>335.00</b>	<b>01</b>

LTP NAME AND SIGNATURE	STRUCTURAL ENG'S NAME AND SIGNATURE	BUILDER NAME AND SIGNATURE	DIGITAL SIGNATURE
SAQUIB JAWED CNP/ENG/0007/2021			

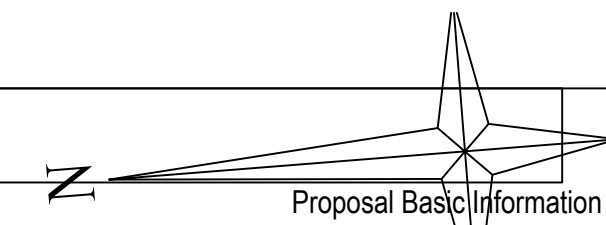

Proposal Basic Information	
Proposal File No.	CNP/BI/0028/W18/2023
Owner Name	M/S.MANGILAL RUNGTA PARTNERSHIP FIRM. REPRESENTED BY ONE OF ITS PARTNER- MR.MUKUND RUNGTA
Khata No	00
Plot No	2905 (OLD), 199 (NEW)
Village Name	Amla Tola
Use	Residential
SubUse	Bungalow/ Dwelling / Non Apartment

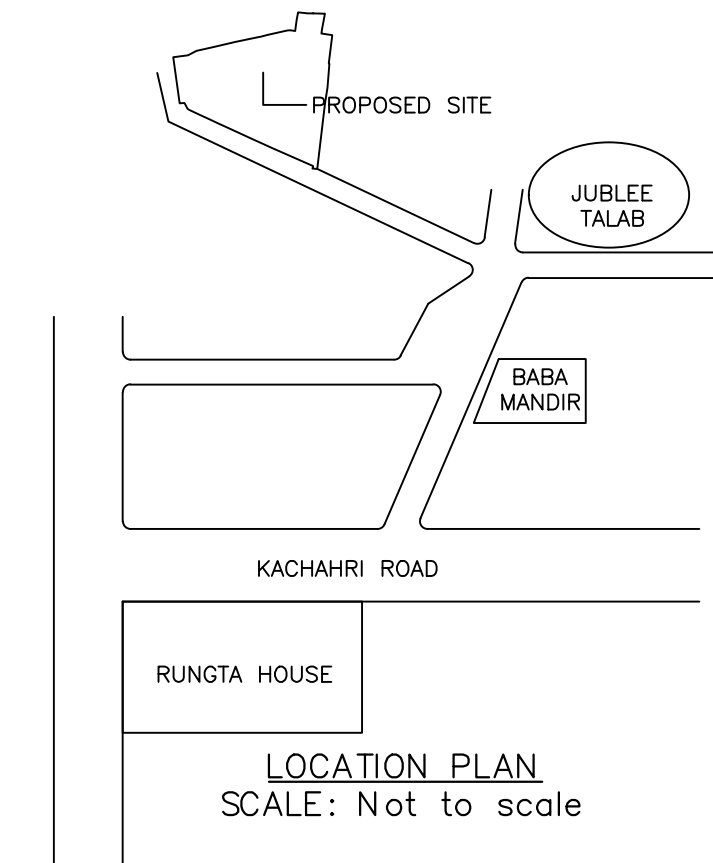
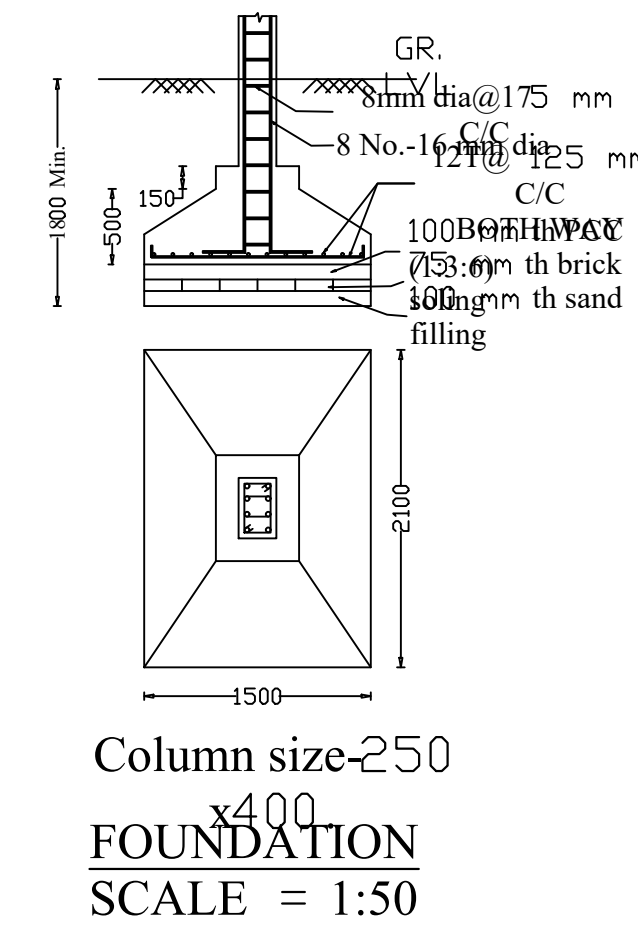
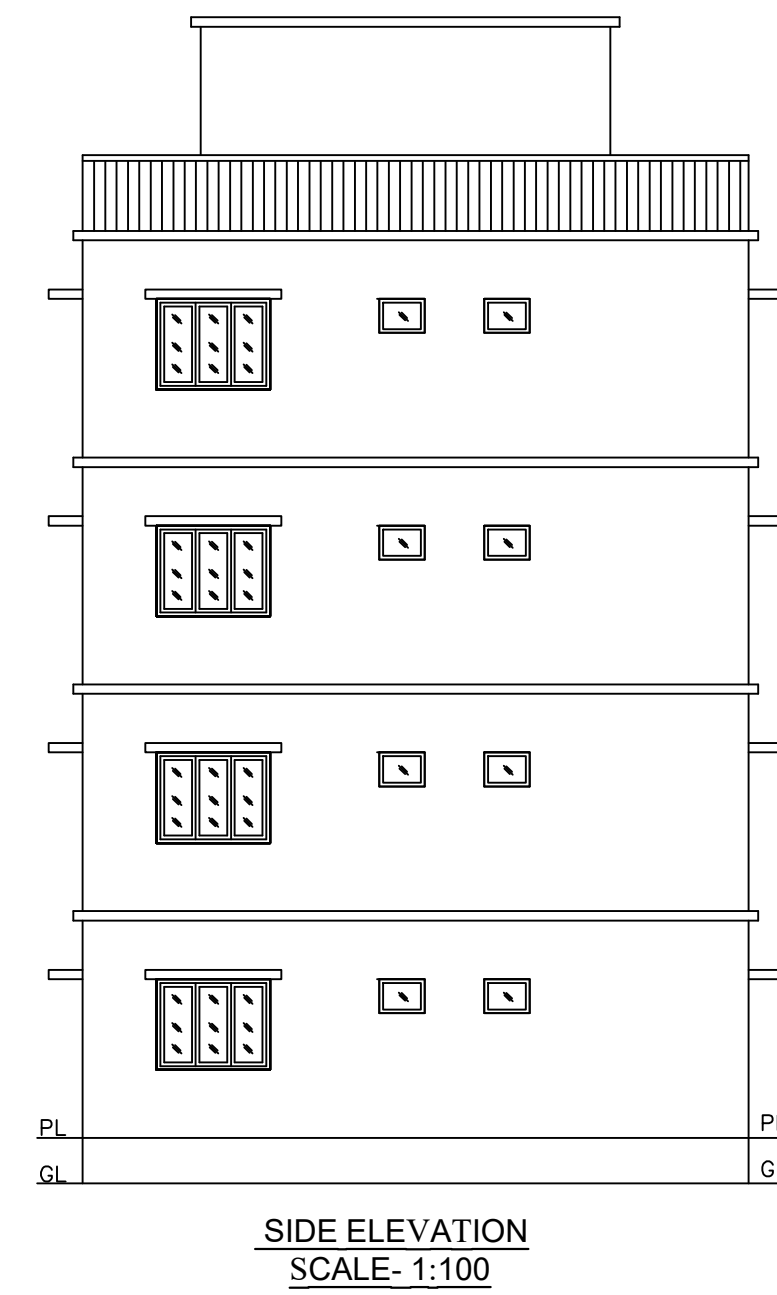
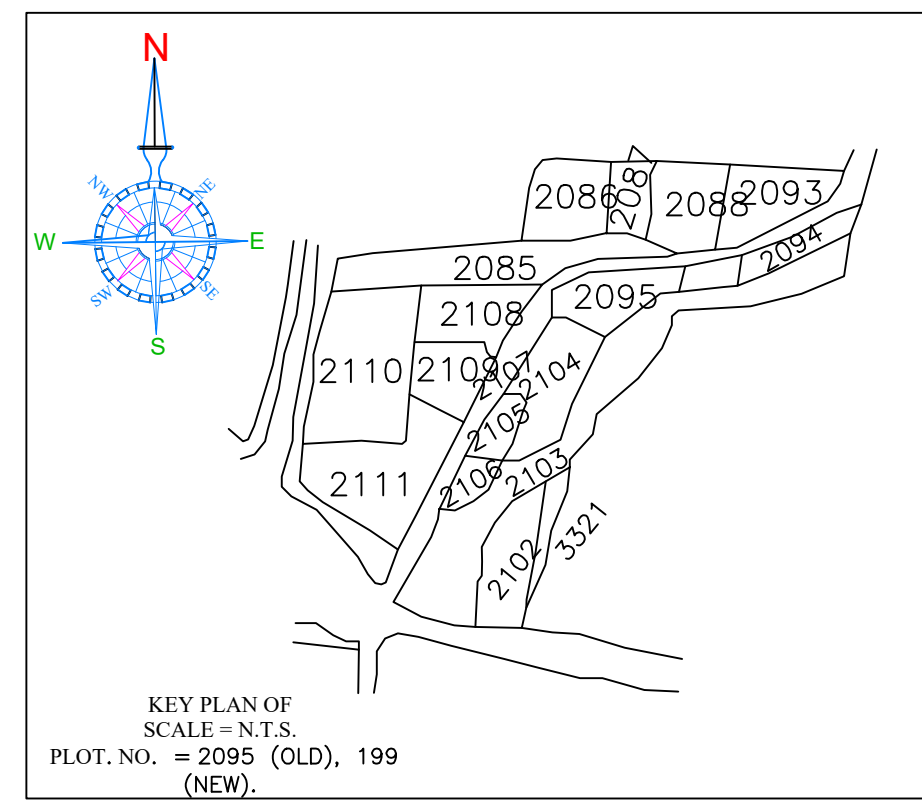
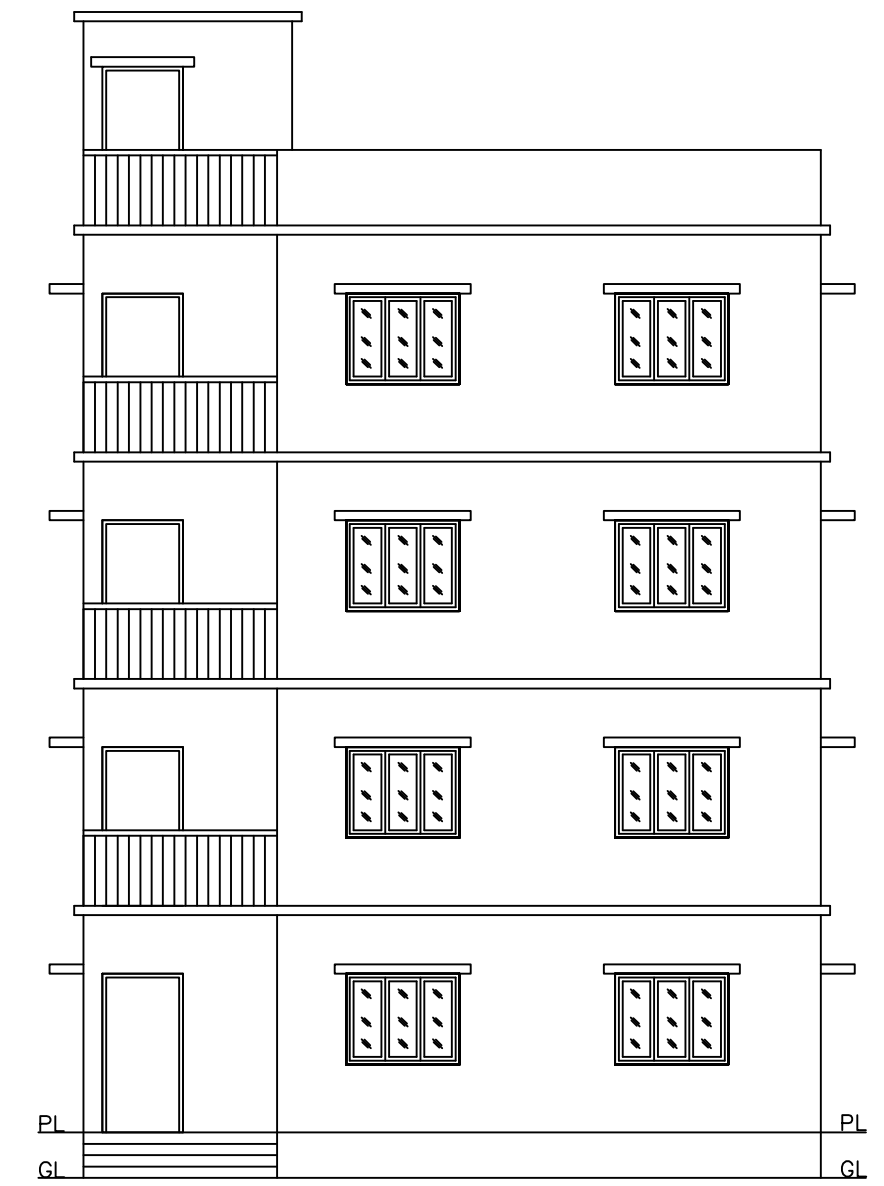
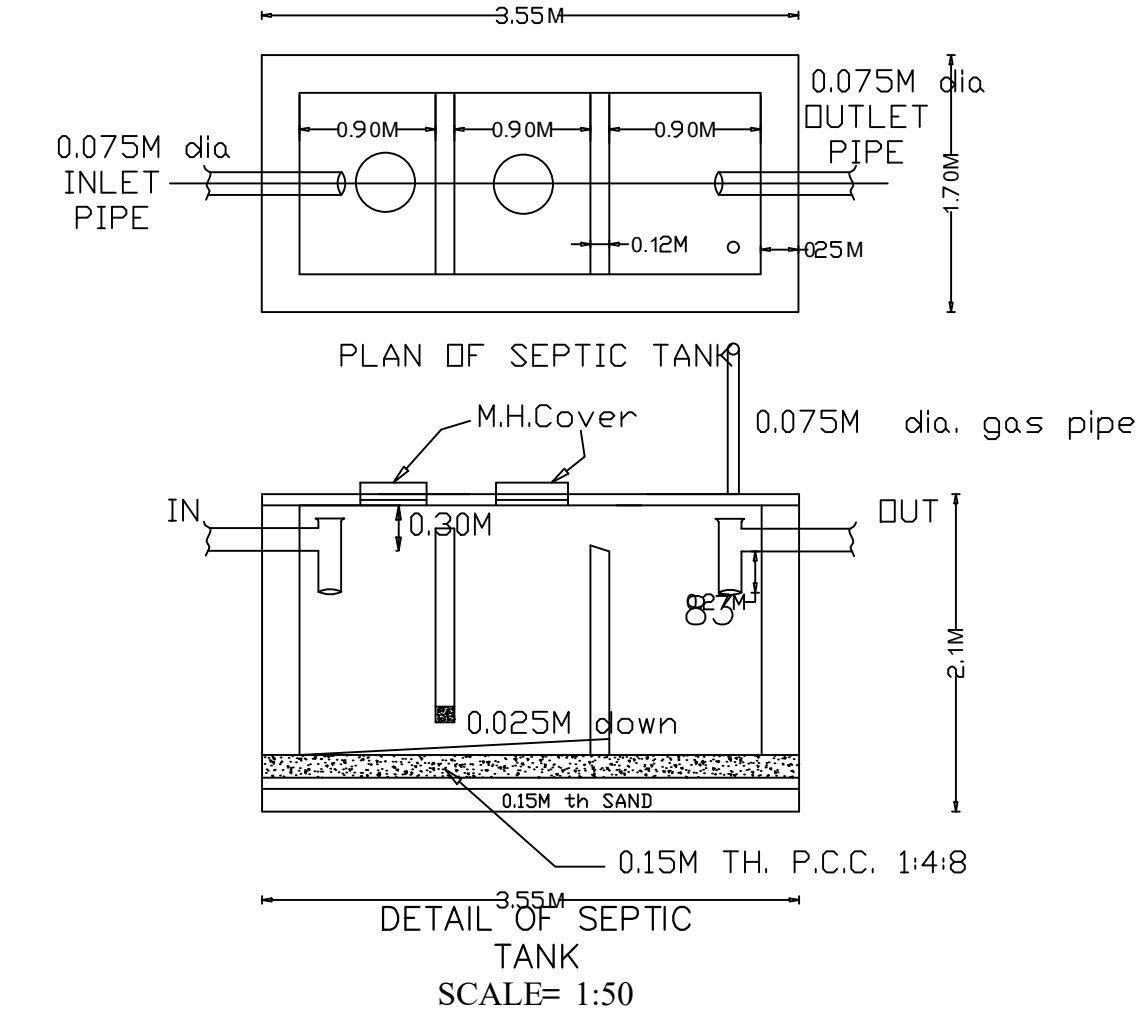
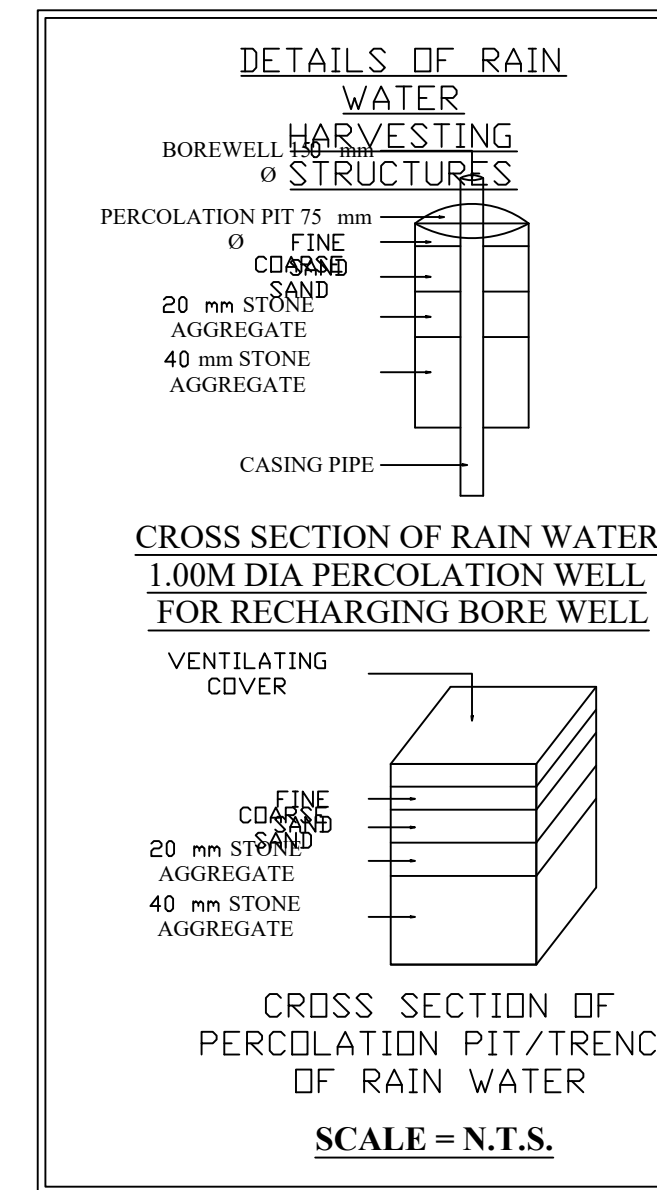
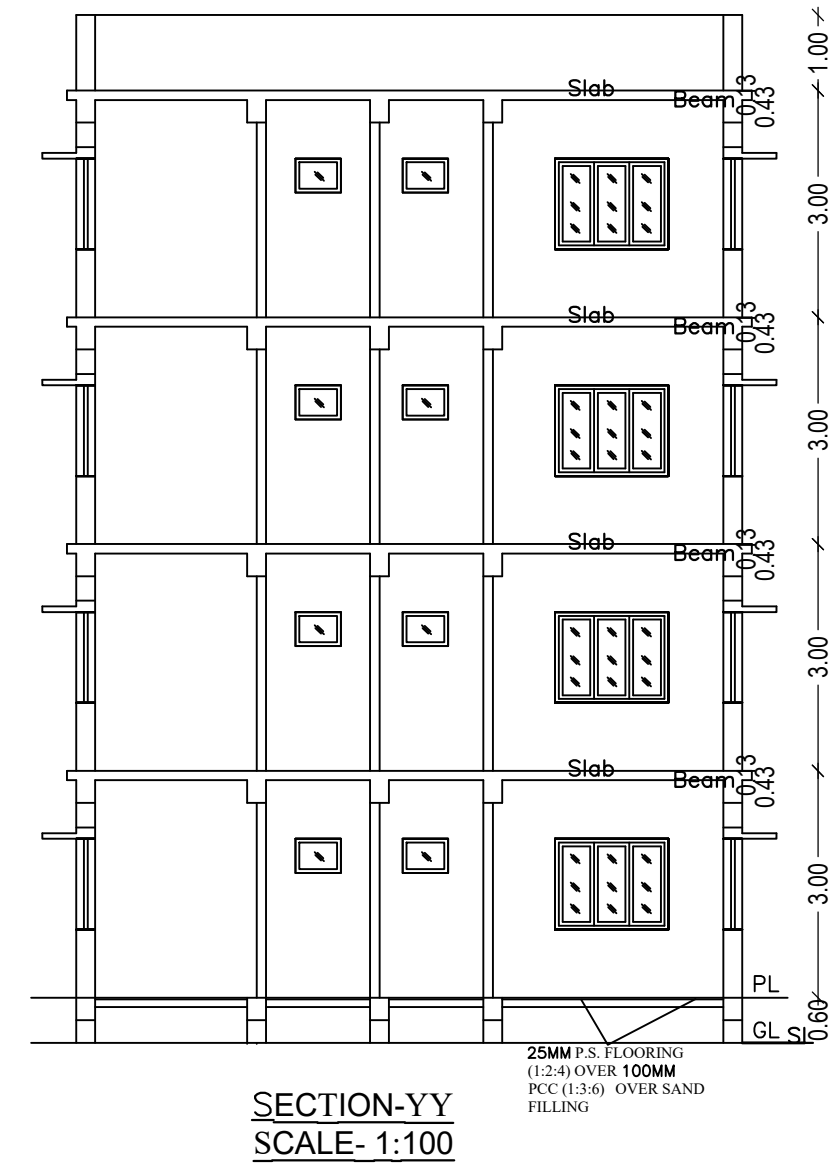
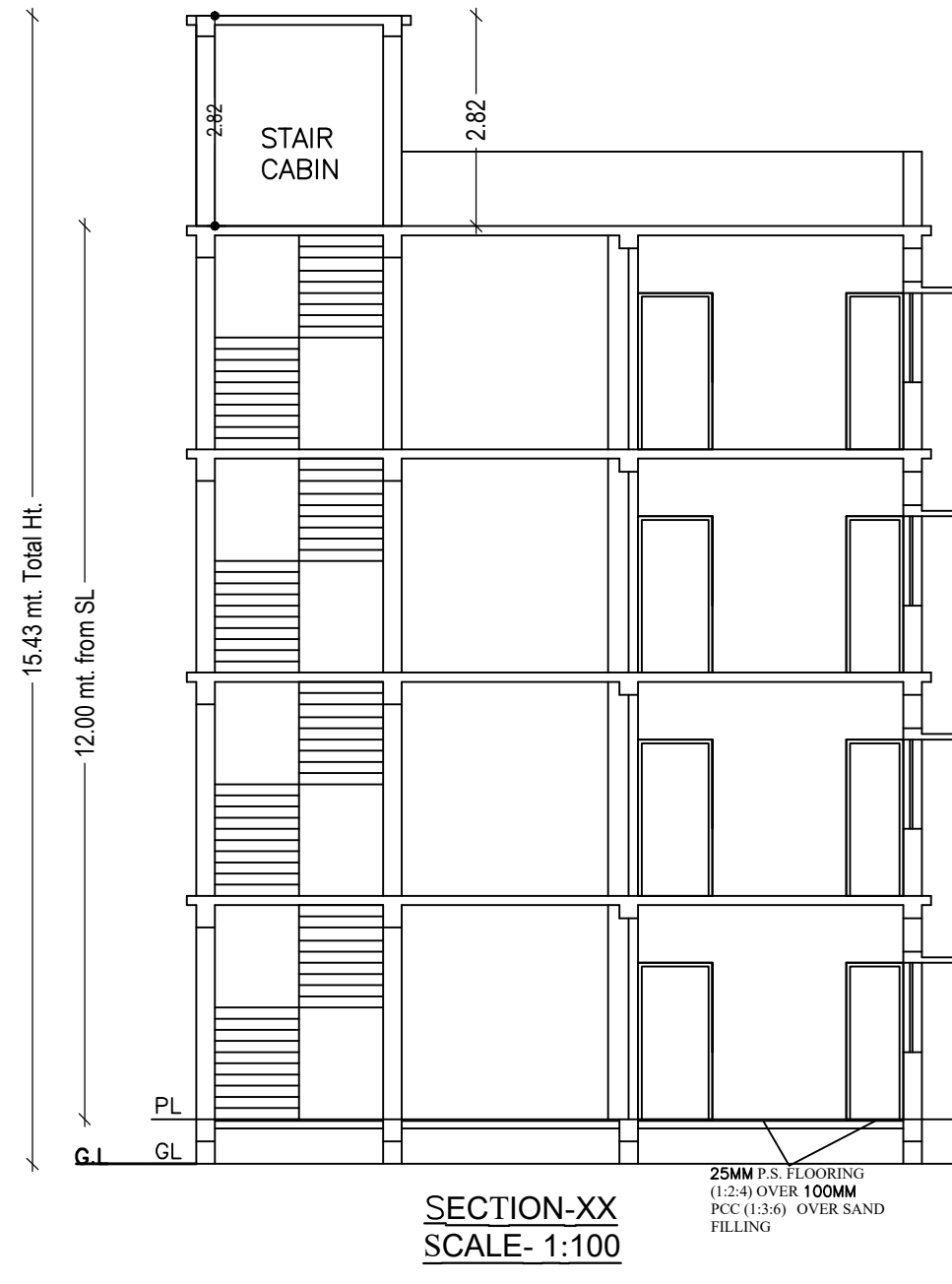

Building :A (RESIDENTIAL)

Floor Name	Total Built Up Area (Sq.mt.)	Proposed FAR Area (Sq.mt.) Resi.	Total FAR Area (Sq.mt.)	Total Consumed Additional FAR Area (Sq.mt.)	Tnmt (No.)
Ground Floor	77.36	77.36	77.36	77.36	01
First Floor	85.88	85.88	85.88	85.88	00
Second Floor	85.88	85.88	85.88	85.88	00
Third Floor	85.88	85.88	85.88	85.88	00
Terrace Floor	0.00	0.00	0.00	0.00	00
Total :	335.00	335.00	335.00	335.00	01
Total Number of Same Buildings	1				
Total :	335.00	335.00	335.00	335.00	01

SCHEDULE OF DOOR:

BUILDING NAME	NAME	LENGTH	HEIGHT	NOS
A (RESIDENTIAL)	D2	0.75	2.10	12
A (RESIDENTIAL)	D1	0.90	2.10	01
A (RESIDENTIAL)	D	1.05	2.10	22

SCHEDULE OF WINDOW/VENTILATION:

BUILDING NAME	NAME	LENGTH	HEIGHT	NOS
A (RESIDENTIAL)	V	0.60	1.20	08
A (RESIDENTIAL)	W1	1.50	1.20	20

UnitBUA Table for Building :A (RESIDENTIAL)

FLOOR	Name	UnitBUA Type	UnitBUA Area	Carpet Area	No. of Rooms	No. of Tenement
GROUND FLOOR PLAN	SPLIT 1	FLAT	252.11	251.39	7	1
TYPICAL - 1, 2& 3 FLOOR PLAN	SPLIT 1	FLAT	0.00	0.00	9	0
Total:	-	-	252.11	251.39	34	1

LTP NAME AND SIGNATURE	STRUCTURAL ENG'S NAME AND SIGNATURE	BUILDER NAME AND SIGNATURE	DIGITAL SIGNATURE
SAQUIB JAWED CNP/ENG/0007/2021			