

SITE PLAN

PROPOSED PLAN
SCALE- 1:100

FAR & Tenement Details (Table 4c-1)

Building	No. of Same Bldg	Total Built Up Area (Sq.mt.)	Deductions (Area in Sq.mt.)		Proposed FAR Area (Sq.mt.)	Add Area In FAR (Sq.mt.)	Total FAR Area (Sq.mt.)	Total Consumed Additional FAR Area (Sq.mt.)	Tnmt (No.)
			Parking	Resi.					
A (RESIDENTIAL)	1	154.89	29.63	119.70	5.56	125.26	125.26	01	
Grand Total :	1	154.89	29.63	119.70	5.56	125.26	125.26	01	

Proposal Basic Information

Proposal File No.	CNP/BP/0006/W14/2024
Owner Name	MRS.SUNITA CHOUDHARY
Khata No	29
Plot No	91
Village Name	Nimdih
Use	Residential
SubUse	Bungalow/ Dwelling / Non Apartment

AREA STATEMENT	VERSION NO. : 1.0.70
CHAIBASA NAGAR PARISHAD	VERSION DATE: 16/10/2020
PROJECT DETAIL:	
Region: JHARKHAND URBAN LOCAL BODIES	Plot Use: Residential
District: WEST SINGHBHUM	Plot SubUse: Bungalow/ Dwelling / Non Apartment
Authority: CHAIBASA NAGAR PARISHAD	PlotNearbyReligiousStructure: NA
Inward No: CNP/BP/0006/W14/2024	PlotSubPlot No: 91
Application Type: General Proposal	North: Plot No. - RASTA
Project Type: Building Permission	South: Plot No. - SHYAM LAL
Nature of Development: New	East: Road Width - 6.20
Location of Development Area: Old Area	West: Plot No. - GYANCHAND JAIN
AREA DETAILS:	
AREA OF PLOT (Minimum)	(A) 128.76
NET AREA OF PLOT(Gross Plot Area - Deduction from Gross Plot area)	(A-Deductions) 128.76
Deduction for Balance Plot Area(from Gross Plot Area)	
Common Plot	19.56
Total	19.56
BALANCE AREA OF PLOT(Net Plot Area - Recreational/Amenity space)	(A-Deductions) 109.20
PLOT AREA FOR COVERAGE(Net Plot Area)	(A-Deductions) 128.76
Plot Area for FAR (Net Plot Area + RoadWidening Area)	(A-Deductions) 128.76
COVERAGE CHECK	
Permissible Coverage area (70.00 %)	90.13
Proposed Coverage Area (27.32 %)	35.18
Total Prop. Coverage Area (27.32 %)	35.18
Balance coverage area (42.68 %)	54.95
FAR CHECK	
Perm. FAR Area (2.000)	257.52
Total Perm. FAR area	257.52
Residential FAR	119.70
Proposed FAR Area	125.26
Total Proposed FAR Area	125.26
Consumed FAR (Factor)	0.97
Balance FAR Area	132.26
BUILT UP AREA CHECK	
Total Proposed BuiltUp Area	154.89
ARCHITECT (Regd)	SAQUIB JAWED
ENGINEER (Regd)	
SUPERVISOR (Regd)	
OWNER (Regd)	MRS.SUNITA CHOUDHARY
DEVELOPMENT AUTHORITY	LOCAL BODY

COLOR INDEX	
PLOT BOUNDARY	[Red Line]
ABUTTING ROAD	[Green Line]
PROPOSED CONSTRUCTION	[Blue Line]
COMMON PLOT	[Yellow Line]
ROAD WIDENING AREA	[Orange Line]
EXISTING (To be retained)	[Purple Line]
EXISTING (To be demolished)	[Light Blue Line]

Buildingwise Floor FAR Details

Floor Name	Building Name A (RESIDENTIAL)		Total	
	Proposed Built Up Area (Sq.mt.)	Proposed FAR Area (Sq.mt.)	Total Proposed Built Up Area (Sq.mt.)	Total FAR Area (Sq.mt.)
Ground Floor	35.19	5.56	35.19	5.56
First Floor	59.85	59.85	59.85	59.85
Second Floor	59.85	59.85	59.85	59.85
Terrace Floor	0.00	0.00	0.00	0.00
Total :	154.89	125.26	154.89	125.26

Building USE/SUBUSE Details

Building Name	Building Use	Building SubUse	Building Structure
A (RESIDENTIAL)	Residential	Bungalow/ Dwelling / Non Apartment	Non-Highrise

LTP NAME AND SIGNATURE	STRUCTURAL ENG'S NAME AND SIGNATURE	BUILDER NAME AND SIGNATURE	DIGITAL SIGNATURE
SAQUIB JAWED CNP/ENG/0007/2021			

Proposal Basic Information

Proposal File No.	CNP/BP/0006/W14/2024
Owner Name	MRS.SUNITA CHOUDHARY
Khata No	29
Plot No	91
Village Name	Nimdihi
Use	Residential
SubUse	Bungalow/ Dwelling / Non Apartment



GROUND FLOOR PLAN (SCALE 1:100)

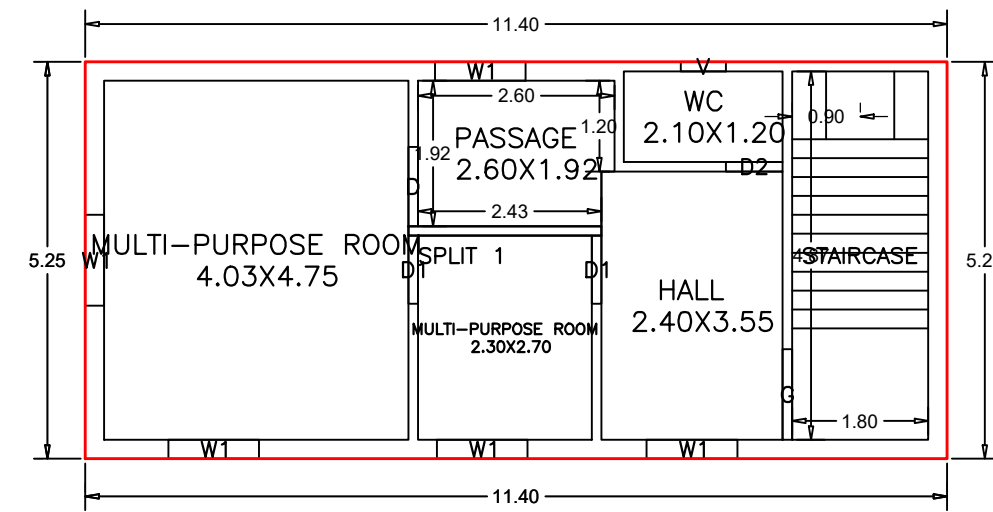

FIRST FLOOR PLAN (Proposed) (SCALE 1:100)

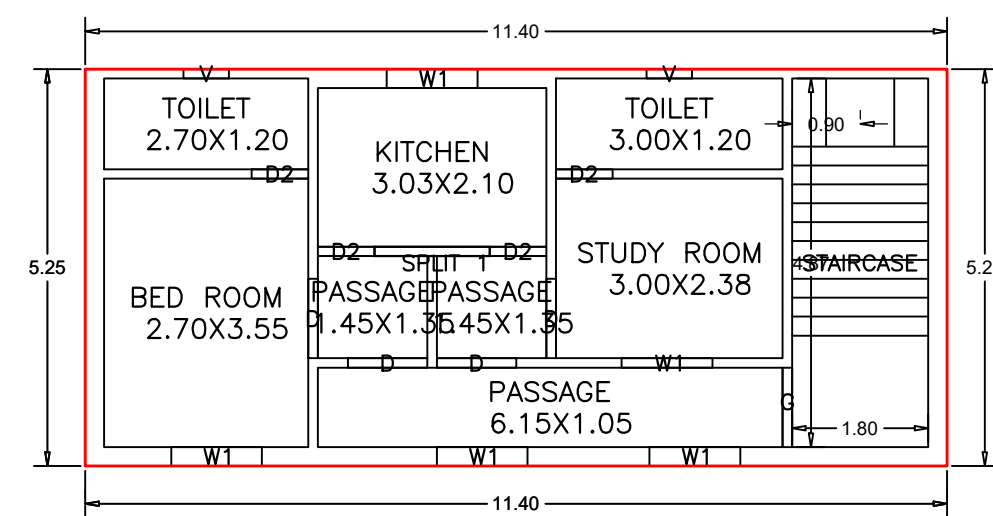

SECOND FLOOR PLAN (Proposed) (SCALE 1:100)

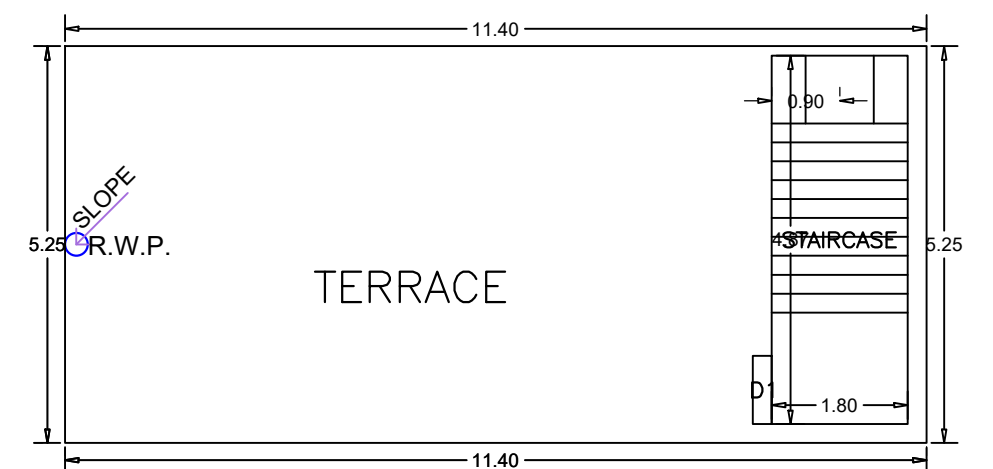

TERRACE FLOOR PLAN (SCALE 1:100)

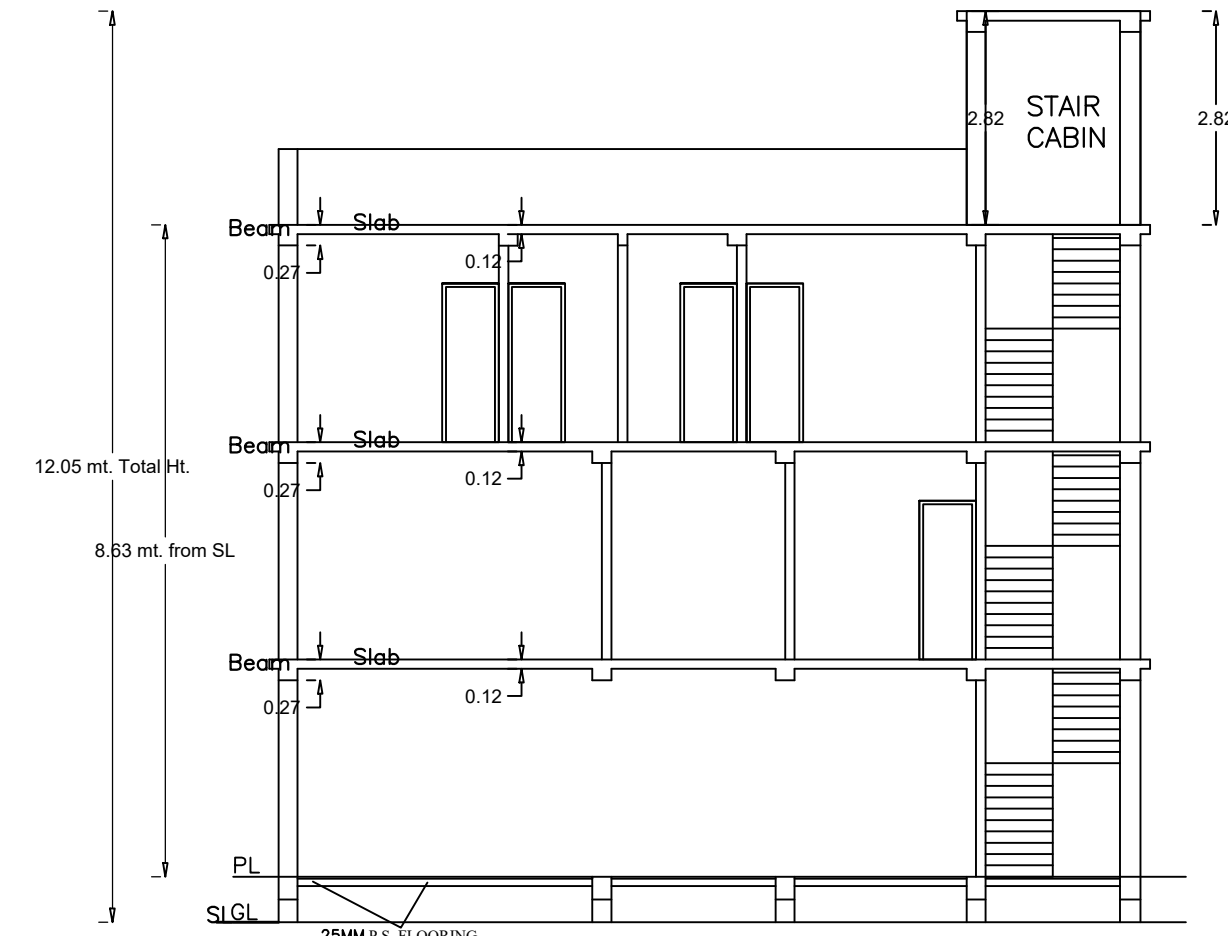

SECTION-XX SCALE- 1:100

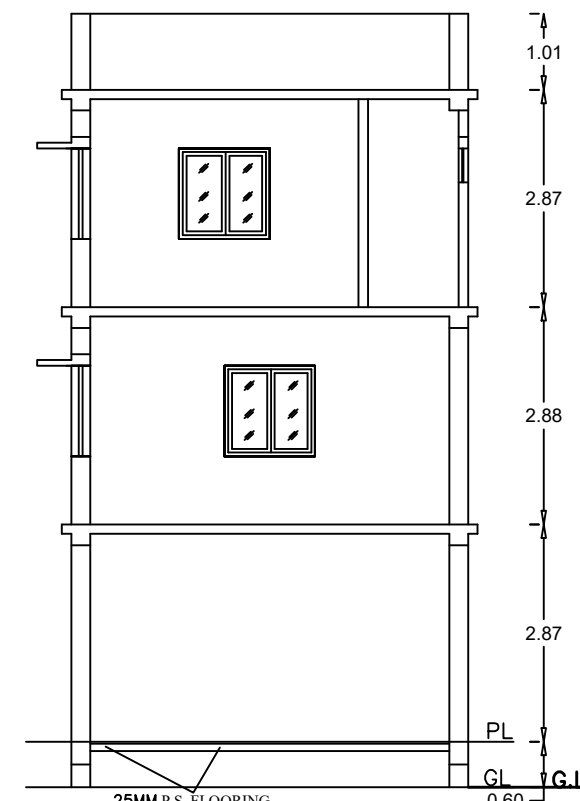

SECTION-YY SCALE- 1:100

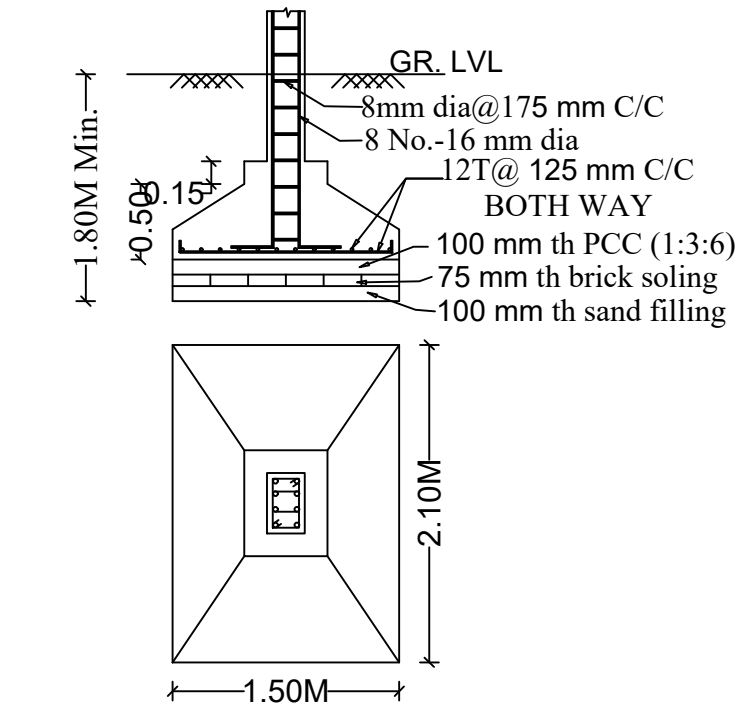

Column size-0.25M x0.40M
FOUNDATION SCALE = 1:50

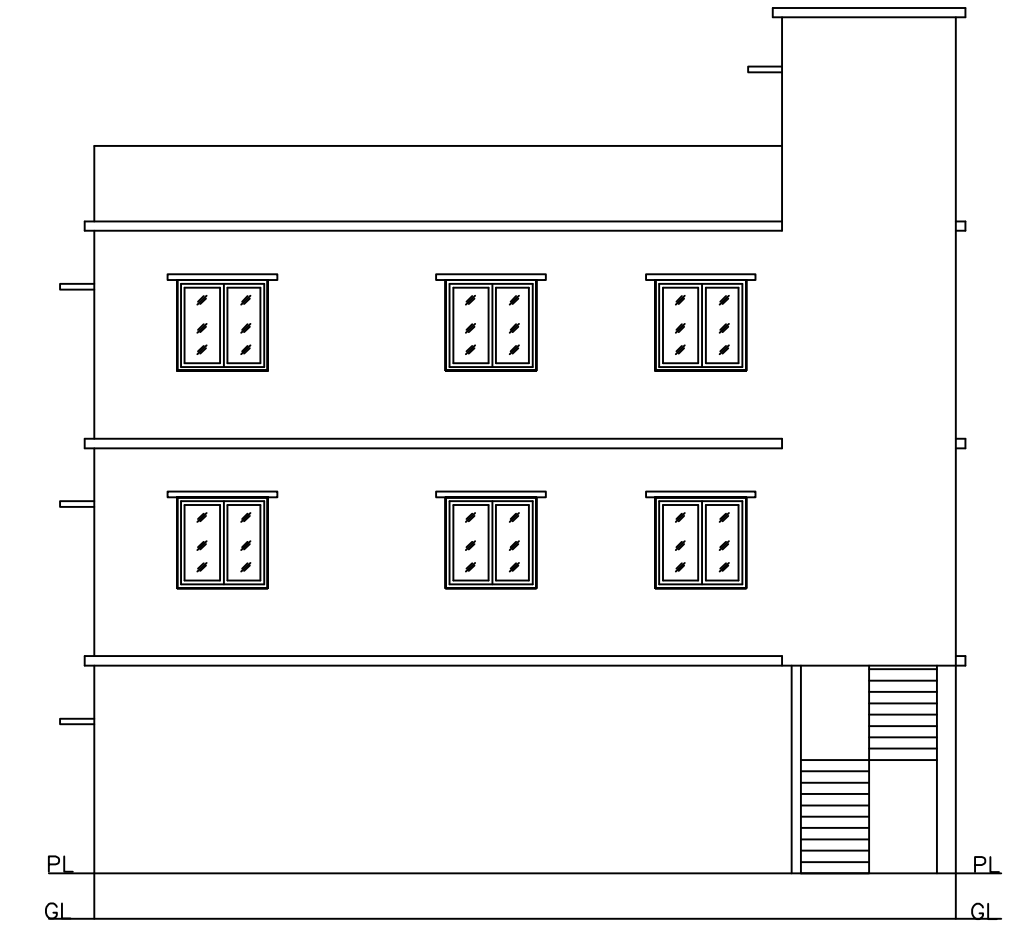

FRONT ELEVATIO SCALE- 1:100

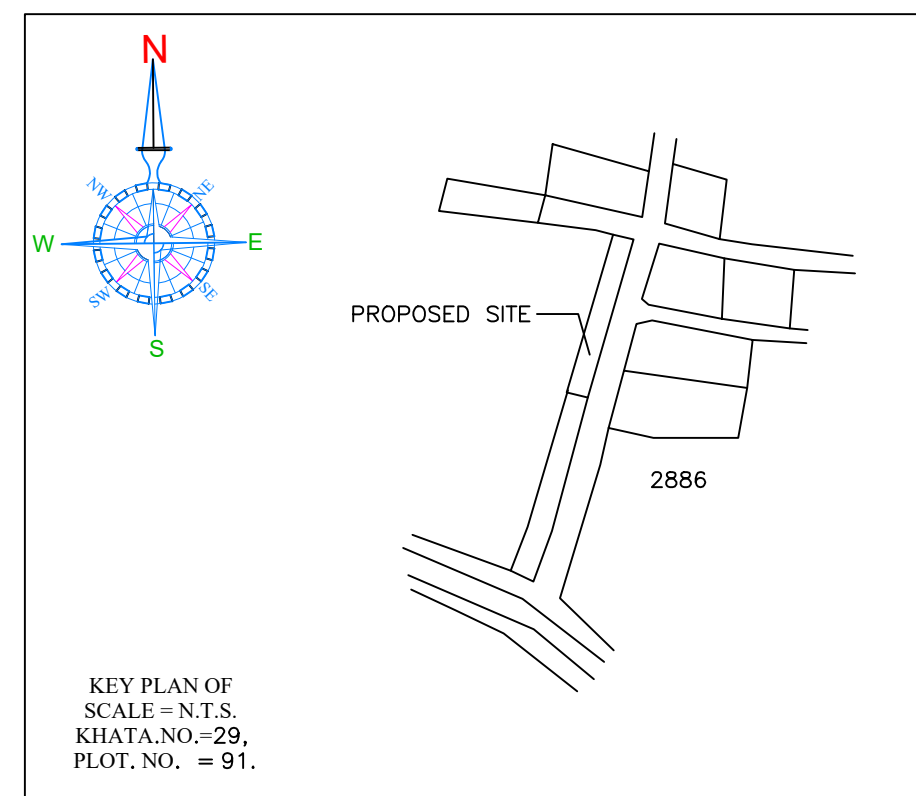

KEY PLAN OF SCALE = N.T.S. KHATA.NO.=29, PLOT. NO. = 91.

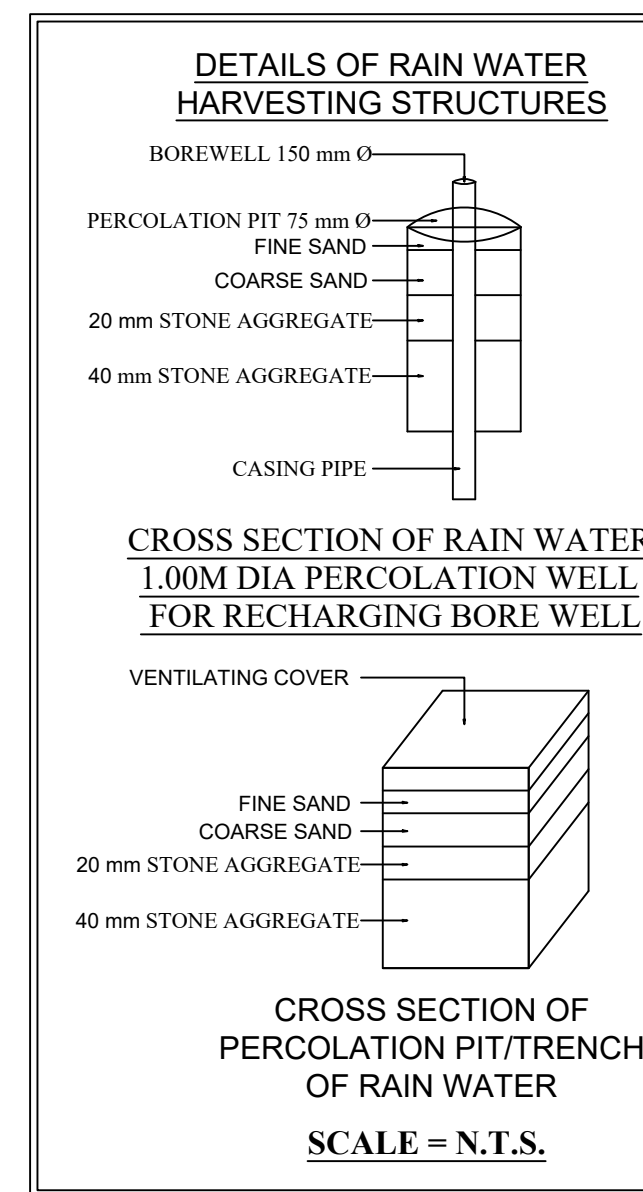

DETAILS OF RAIN WATER HARVESTING STRUCTURES

BOREWELL 150 mm Ø
PERCOLATION PIT 75 mm Ø
FINE SAND
COARSE SAND
20 mm STONE AGGREGATE
40 mm STONE AGGREGATE
CASING PIPE

CROSS SECTION OF RAIN WATER 1.00M DIA PERCOLATION WELL FOR RECHARGING BORE WELL

VENTILATING COVER
FINE SAND
COARSE SAND
20 mm STONE AGGREGATE
40 mm STONE AGGREGATE

CROSS SECTION OF PERCOLATION PIT/TRENCH OF RAIN WATER
SCALE = N.T.S.

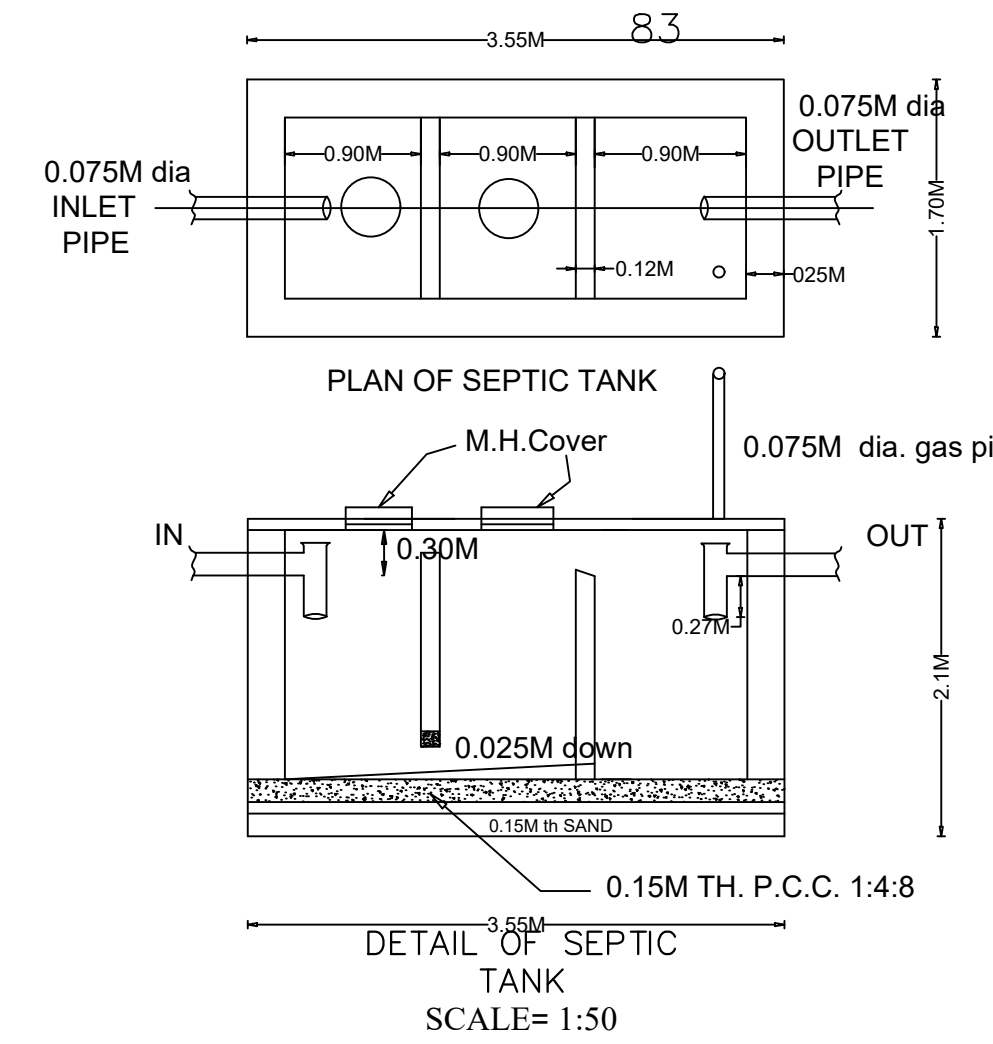

DETAIL OF SEPTIC TANK SCALE= 1:50

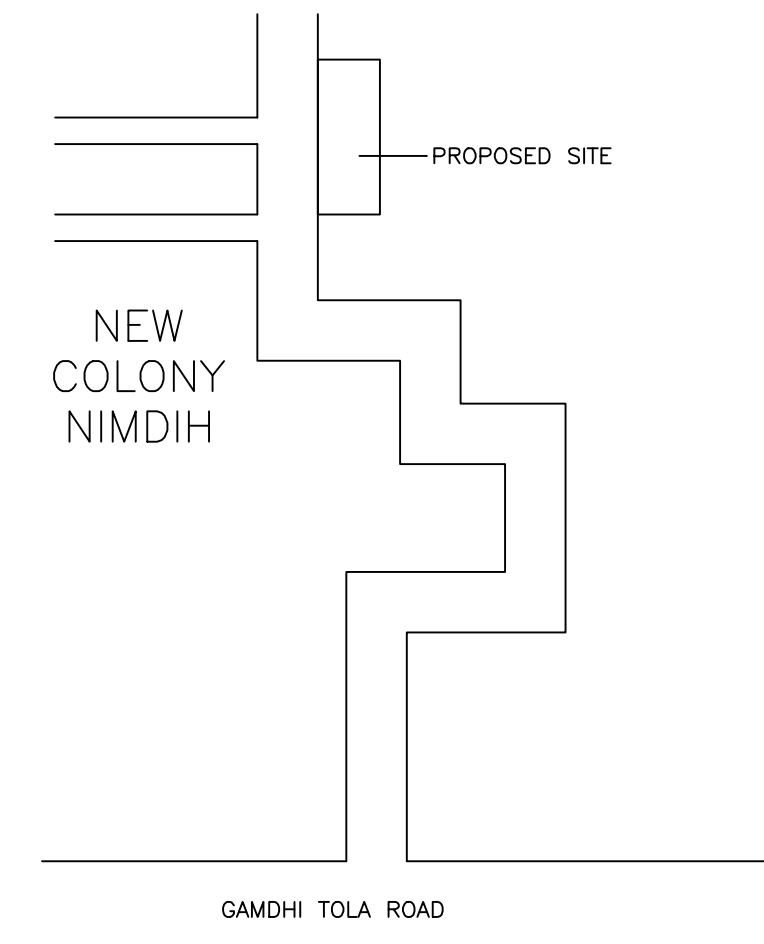

GANDHI TOLA ROAD
NEW COLONY NIMDIH

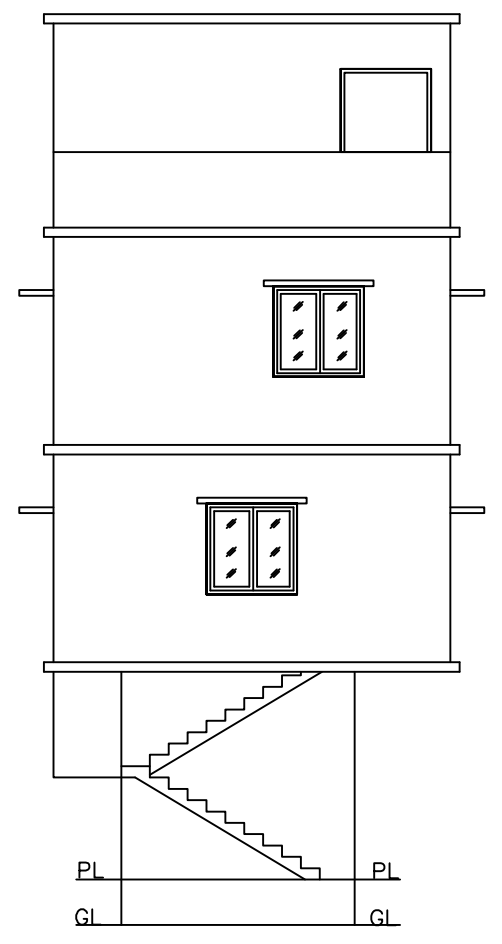

SIDE ELEVATIO SCALE- 1:100

Building :A (RESIDENTIAL)

Floor Name	Total Built Up Area (Sq.mt)	Deductions (Area in Sq.mt.)		Proposed FAR Area (Sq.mt.)	Add Area In FAR (Sq.mt.)	Total FAR Area (Sq.mt.)	Total Consumed Additional FAR Area (Sq.mt.)	Trmt (No.)
		Parking	Resi.					
Ground Floor	35.19	29.63	0.00	5.56	5.56	5.56	0.00	00
First Floor	59.85	0.00	59.85	0.00	59.85	59.85	0.00	01
Second Floor	59.85	0.00	59.85	0.00	59.85	59.85	0.00	00
Terrace Floor	0.00	0.00	0.00	0.00	0.00	0.00	0.00	00
Total :	154.89	29.63	119.70	5.56	125.26	125.26	0.00	01
Total Number of Same Buildings	1							
Total :	154.89	29.63	119.70	5.56	125.26	125.26	0.00	01

SCHEDULE OF DOOR:

BUILDING NAME	NAME	LENGTH	HEIGHT	NOS
A (RESIDENTIAL)	D2	0.75	2.10	05
A (RESIDENTIAL)	D1	0.90	2.10	02
A (RESIDENTIAL)	D	1.05	2.10	05
A (RESIDENTIAL)	G	1.05	2.10	01
A (RESIDENTIAL)	G	1.20	2.10	01

SCHEDULE OF WINDOW/VENTILATION:

BUILDING NAME	NAME	LENGTH	HEIGHT	NOS
A (RESIDENTIAL)	V	0.60	1.20	03
A (RESIDENTIAL)	W1	1.20	1.20	10

UnitBUA Table for Building :A (RESIDENTIAL)

FLOOR	Name	UnitBUA Type	UnitBUA Area	Carpet Area	No. of Rooms	No. of Tenement
FIRST FLOOR PLAN	SPLIT 1	FLAT	86.24	85.73	5	1
SECOND FLOOR PLAN	SPLIT 1	FLAT	0.00	0.00	8	0
Total:	-	-	86.24	85.73	13	1

LTP NAME AND SIGNATURE	STRUCTURAL ENG'S NAME AND SIGNATURE	BUILDER NAME AND SIGNATURE	DIGITAL SIGNATURE
SAQUIB JAWED CNP/ENG/0007/2021			