

COLOR INDEX	
PLOT BOUNDARY	Black
ABUTTING ROAD	Green
PROPOSED CONSTRUCTION	Red
COMMON PLOT	Yellow
ROAD WIDENING AREA	Orange
EXISTING (To be retained)	Blue
EXISTING (To be demolished)	Light Blue

AREA STATEMENT (DUMKA NAGAR PARISHAD)		VERSION NO.: 1.0.14
PROJECT DETAIL:		VERSION DATE: 11/07/2017
Region: JHARKHAND URBAN LOCAL BODIES	Plot Use: Residential	
District: DUMKA	Plot SubUse: Residential Bldg/Apartment	
Authority: DUMKA NAGAR PARISHAD	Plot/Nearby/Religious Structure: NA	
Inward No: DNP/BP/0002/W05/2017	Plot/SubPlot No: 507 part	
Application Type: General Proposal	North: Plot No. - 507	
Project Type: Building Permission	South: Plot No. - 507	
Nature of Development: New	East: Road Width - 6.10	
Location of Development Area: Old Area	West: Plot No. - 507	
AREA DETAILS:		SQ.MT.
AREA OF PLOT (Minimum)	(A)	80.84
NET AREA OF PLOT (Gross Plot Area - Deduction from Gross Plot Area)	(A-Deductions)	80.84
Deduction for Balance Plot Area (from Gross Plot Area)		
Common Plot		8.34
Total		8.34
BALANCE AREA OF PLOT (Net Plot Area - Recreational/Amenity spaces)	(A-Deductions)	72.50
PLOT AREA FOR COVERAGE (Net Plot Area)	(A-Deductions)	80.84
Plot Area for FAR (Net Plot Area + Road Widening Area)	(A-Deductions)	80.84
COVERAGE CHECK		
Permissible Coverage area (70.00 %)		56.59
Proposed Coverage Area (44.09 %)		35.64
Total Prop. Coverage Area (44.09 %)		35.64
Balance coverage area (25.92 %)		20.95
FAR CHECK		
Perm. FAR Area (2.50)		202.10
Total Perm. FAR area		202.10
Residential FAR		71.28
Proposed FAR Area		71.28
Total Proposed FAR Area		71.28
Consumed FAR (Factor)		0.88
Balance FAR Area		130.82
BUILT UP AREA CHECK		
Total Proposed BuiltUp Area		71.28
ARCHITECT (Regd)	SARAT CHANDRA PANJIYARA	
ENGINEER (Regd)		
SUPERVISOR (Regd)		
OWNER (Regd)	RAJENDRA PD SAH	
DEVELOPMENT AUTHORITY LOCAL BODY		

Buildingwise Floor FAR Details

Floor Name	Building Name		Total	
	A (RESIDENTIAL)		Total Proposed Built Up Area (Sq.mt.)	Total FAR Area (Sq.mt.)
Ground Floor	35.64	35.64	35.64	35.64
First Floor	35.64	35.64	35.64	35.64
Terrace Floor	0.00	0.00	0.00	0.00
Total:	71.28	71.28	71.28	71.28

FAR & Tenement Details (Table 4c-1)

Building	No. of Same Bldg	Total Built Up Area (Sq.mt.)	Proposed FAR Area (Sq.mt.) Resi.	Total FAR Area (Sq.mt.)	Total Consumed Additional FAR Area (Sq.mt.)	Trnmt (No.)
Grand Total:	1	71.28	71.28	71.28	71.28	1.00

Building :A (RESIDENTIAL)

Floor Name	Total Built Up Area (Sq.mt.)	Proposed FAR Area (Sq.mt.) Resi.	Total FAR Area (Sq.mt.)	Total Consumed Additional FAR Area (Sq.mt.)	Trnmt (No.)
First Floor	35.64	35.64	35.64	35.64	00
Terrace Floor	0.00	0.00	0.00	0.00	00
Total:	71.28	71.28	71.28	71.28	01
Total Number of Same Buildings					
Total:	71.28	71.28	71.28	71.28	01

SCHEDULE OF DOOR:

BUILDING NAME	NAME	LENGTH	HEIGHT	NOS
A (RESIDENTIAL)	D1	0.90	2.10	02
A (RESIDENTIAL)	D1	1.00	2.10	02

SCHEDULE OF WINDOW/VENTILATION:

BUILDING NAME	NAME	LENGTH	HEIGHT	NOS
A (RESIDENTIAL)	V	1.00	1.20	02
A (RESIDENTIAL)	W	1.20	1.20	16

Building USE/SUBUSE Details

Building Name	Building Use	Building SubUse	Building Structure
A (RESIDENTIAL)	Residential	Bungalow/ Dwelling / Non Apartment	Non-Highrise

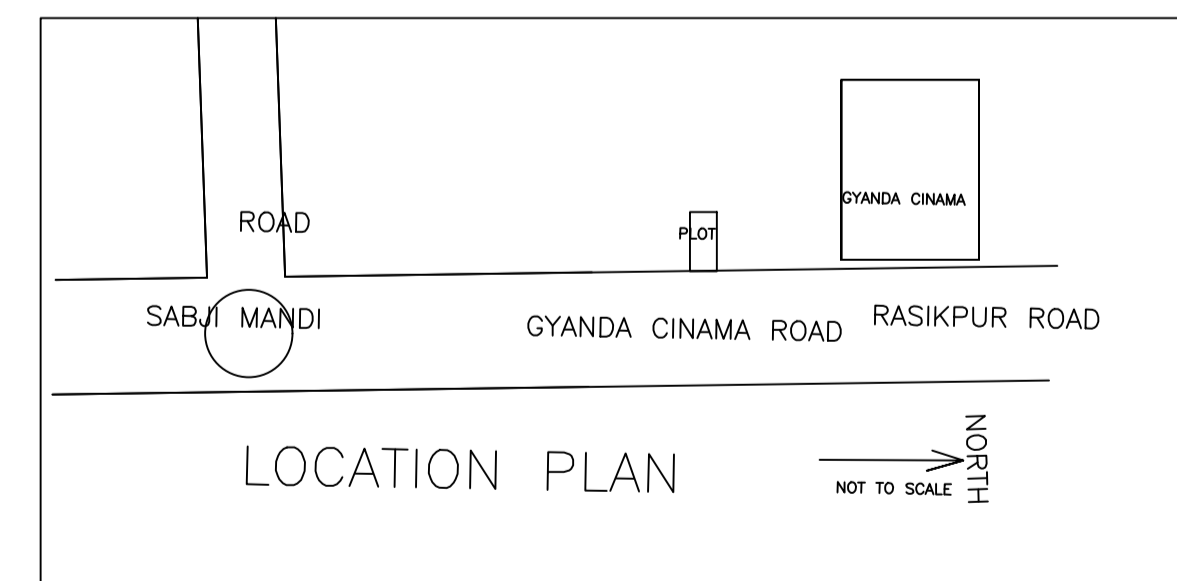
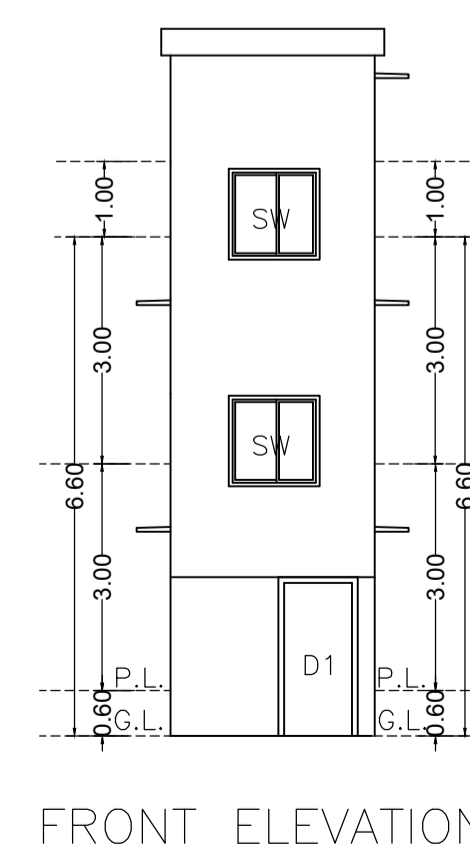
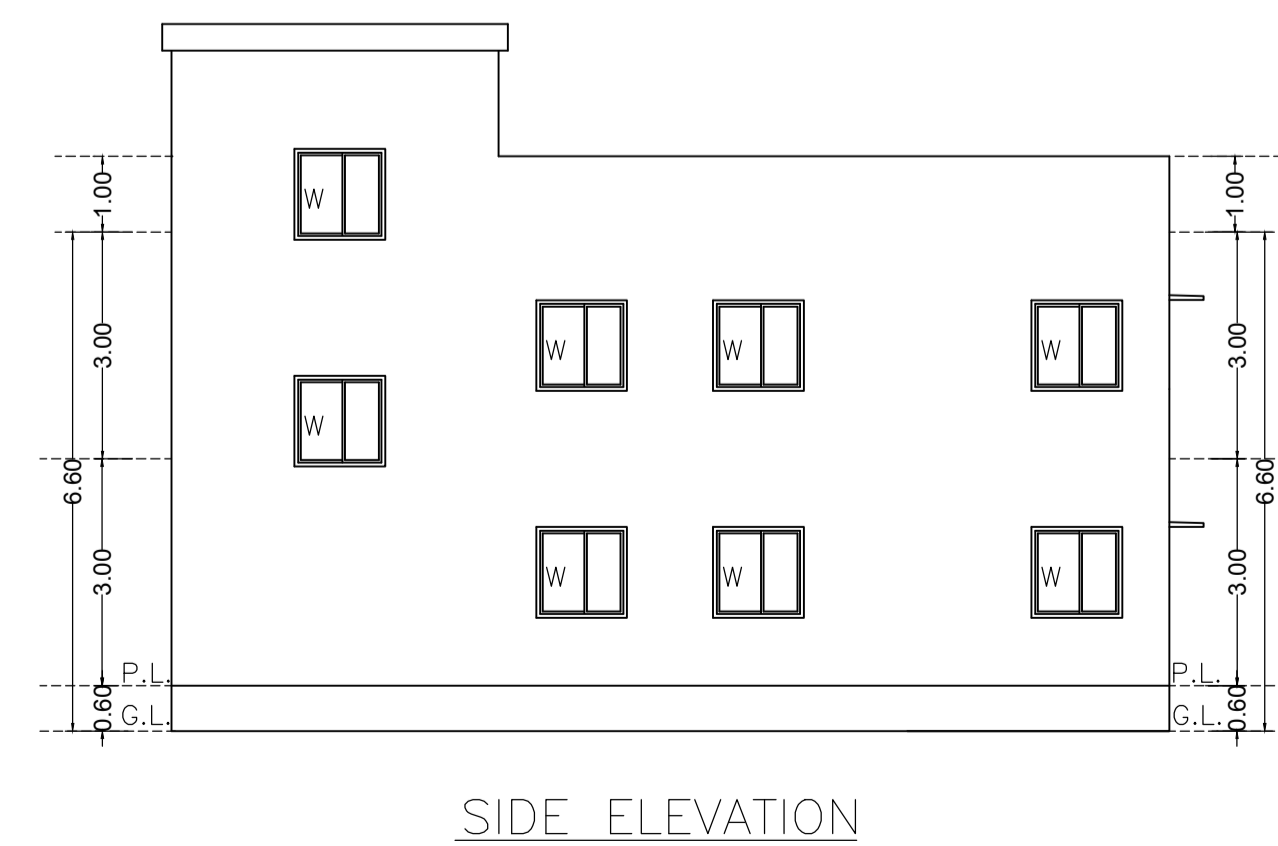
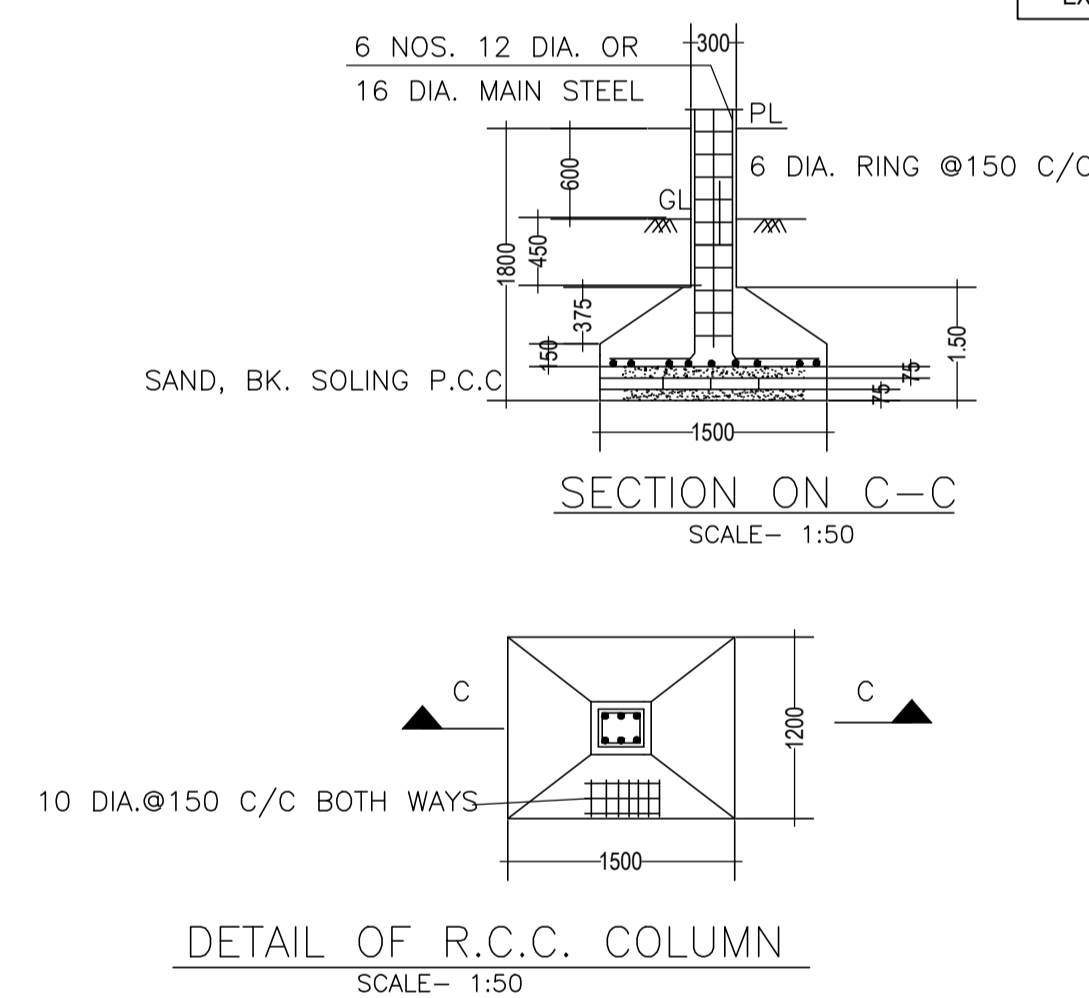
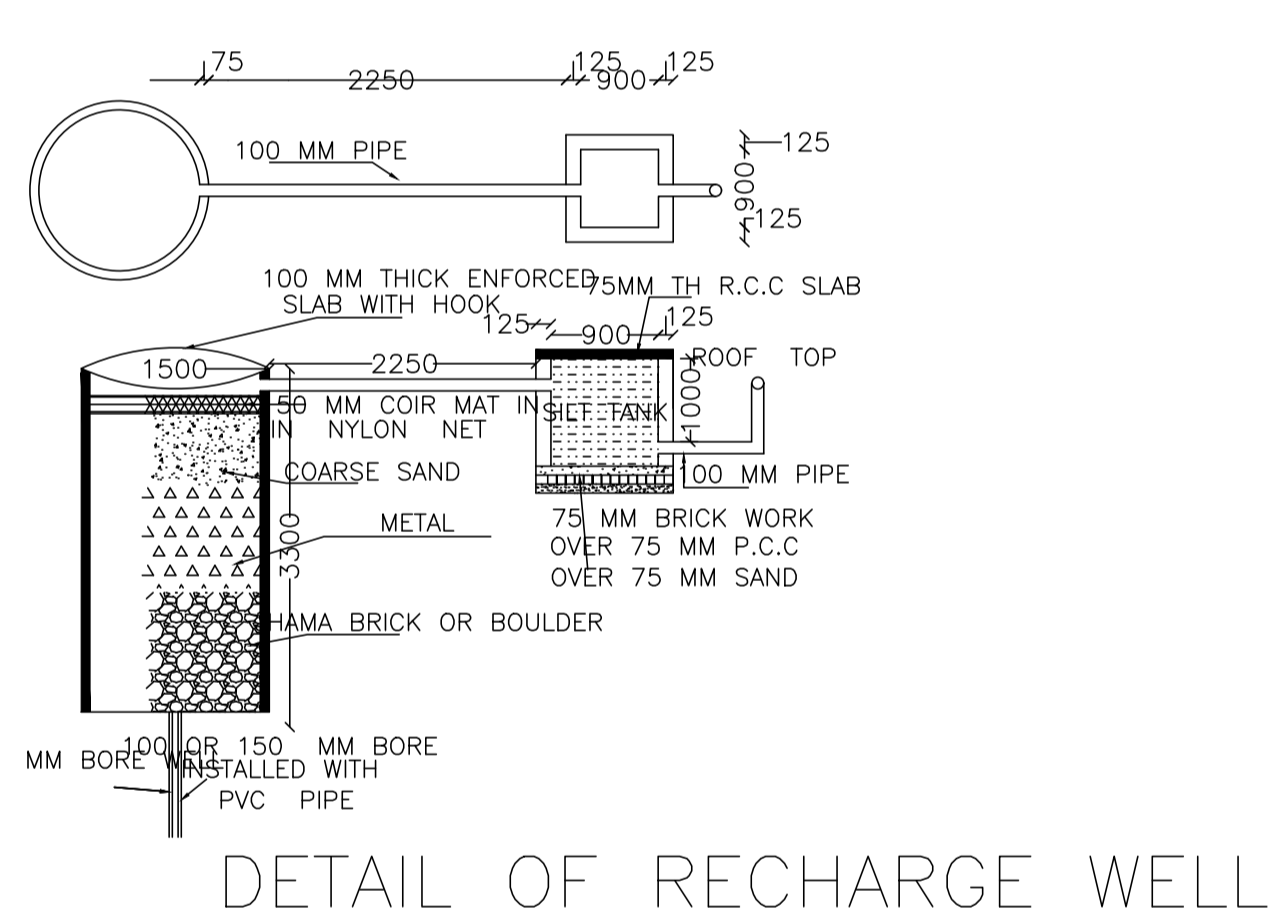
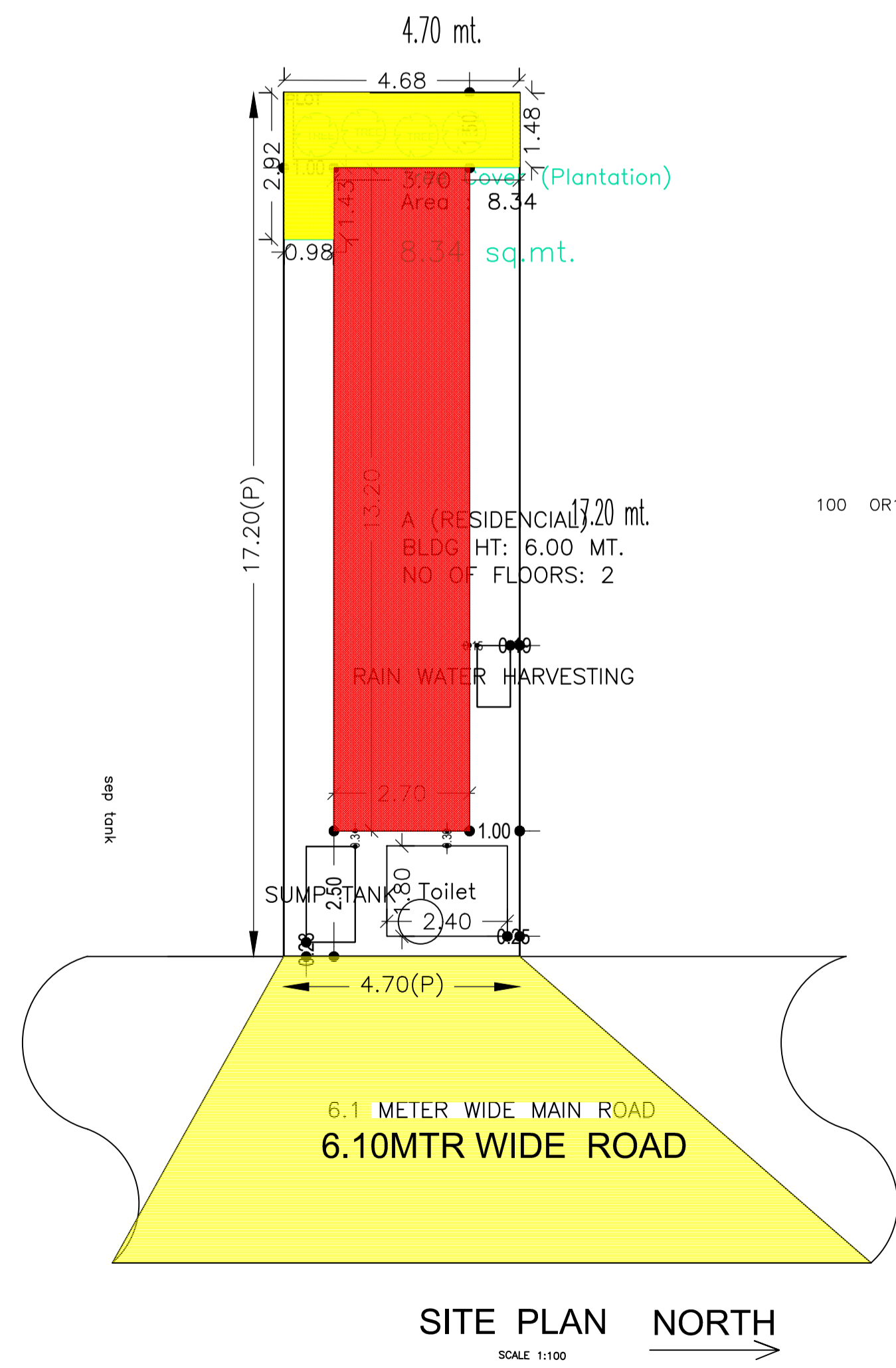

LTP NAME AND SIGNATURE	STRUCTURAL ENG'S NAME AND SIGNATURE	BUILDER NAME AND SIGNATURE
SARAT CHANDRA PANJIYARA DNP/SUP/0002/2016		