

Project Title : JANARDHAN PRASAD SAH

AREA STATEMENT: DUMKA NAGAR PARISHAD	VERSION NO. 1.0.20
PROJECT DETAIL:	VERSION DATE: 01/01/2019
Plot No.:	Plot Use: Residential
Region: JHARKHAND URBAN LOCAL BODIES	Plot Sub Use: Bungalow Dwelling / Non Apartment
District: DUMKA	Land Use Zone: N/A
Population Type: General Proposed	Abutting Road Width:
Project Type: Building Permission	Plot No.:
Location: Old Area	Revenue Survey No/Survey No.:
Sub Location: NA	Town No.:
Village/Moosa Name:	Ward No.:
Ward No.:	North:
East:	South:
West:	East:

AREA OF PLOT (Minimum)	(A)	67.41
Deduction for Net Plot Area		3.20
Net Plot Area (Gross Plot Area - Deduction from Gross Plot Area)	(A-Deductions)	64.21
Free Cilled R/W Area		3.20
COP Area		6.57
Balance Plot Area (Net Plot Area - Recreational/Accrually space)	(A-Deductions)	58.04
Plot Area for Coverage (Net Plot Area)	(A-Deductions)	64.21
Plot Area for FSI (Net Plot Area + Road/Walkway Area)	(A-Deductions)	67.41
Accessory/Live Area		0.85
COVERAGE CHECK		
Proposed Coverage Area (45.12 %)		31.54
Total Coverage Area (45.12 %)		31.54
FAR CHECK		
Proposed Area of FAR		63.08
Total Area of FAR		63.08
BUILT UP AREA CHECK		
Total Proposed Built Up Area		63.08
PROJ. LENGTH SUPERSEDED (Road)	OWNER	
DEVELOPMENT AUTHORITY	LOCAL BODY	

COLOR INDEX	
FLYING ROAD	██████████
PROPOSED WORK (COVERAGE AREA)	██████████
EXISTING (To be retained)	██████████
EXISTING (To be demolished)	██████████

PARKING CALCULATION:		
Parking Type	Prop No.	Prop Area
Other Parking	1	15.56
Total Area	1	15.56

MARGIN DETAIL:					
Building / Wing	Road Name	Front Margin	Rear Margin	Side Margin	Stack Margin
A (JANARDHAN PRASAD SAH)	ROAD WIDENING AREAS/SURRENDERED FREE OF COST	2.53	1.84	0.27	1.06

FAR & Tenement Details (Table 4c-1)					
Building	No. of Same Bldg	Total Built Up Area (Sq.mt)	Proposed FAR Area (Sq.mt)	Total FAR Area (Sq.mt)	Tenent (No.)
A (JANARDHAN PRASAD SAH)	1	63.08	63.08	63.08	01
Gross Total	1	63.08	63.08	63.08	01

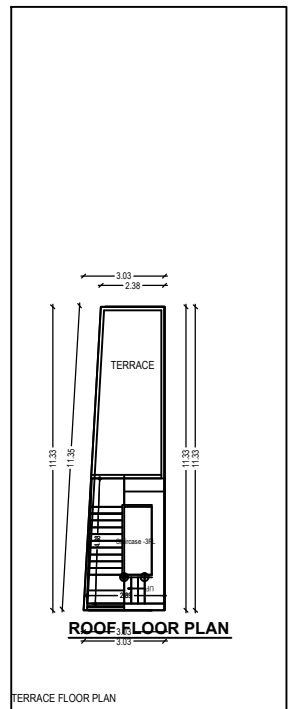
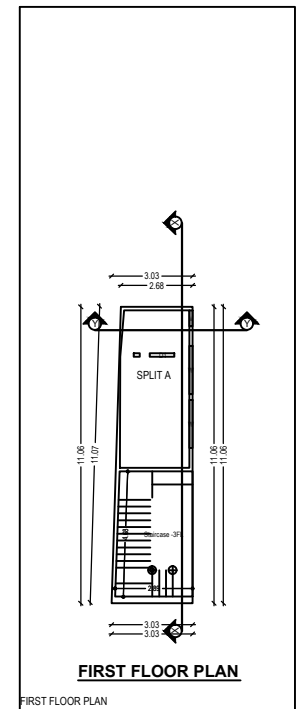
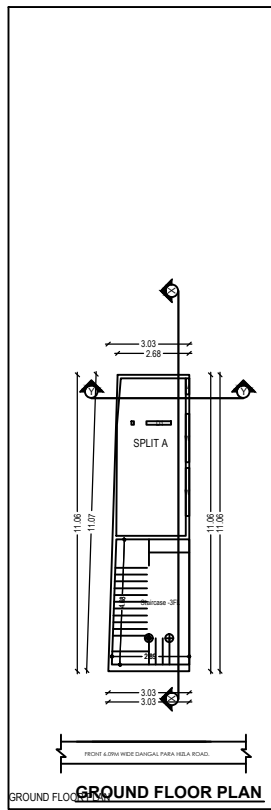
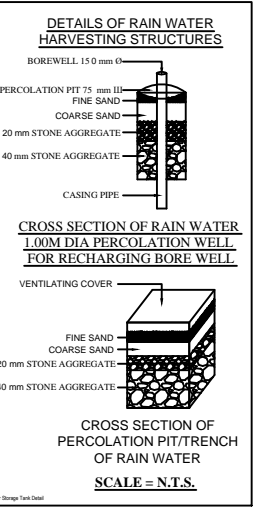
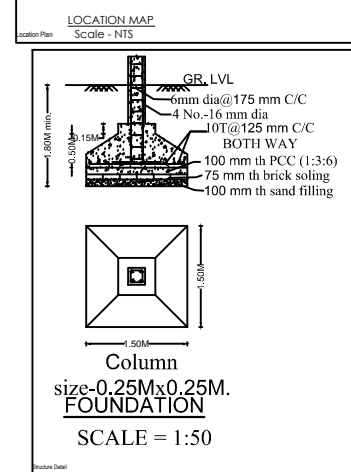
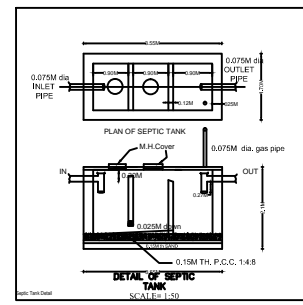
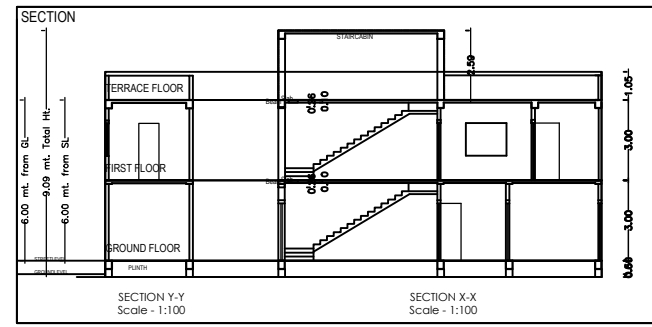
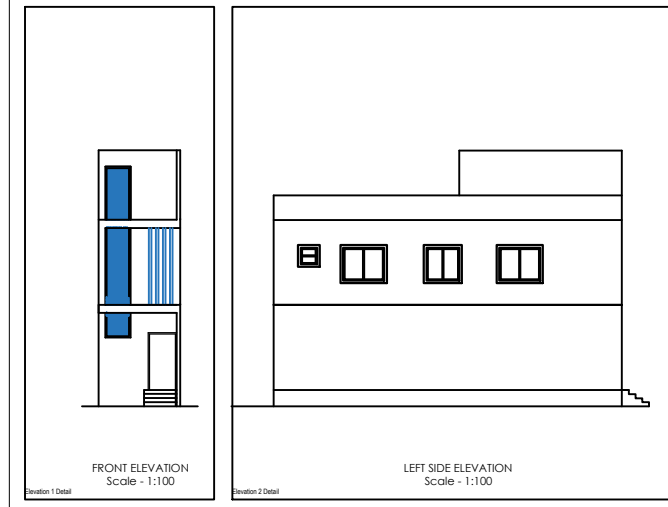

SCHEDULE OF DOOR & WINDOWS				
TYPE	WIDTH	HT.	SILL	DESCRIPTION
D1	0.76	2.13	0.00	SAL WOOD FRAME FLUSH DOOR
D2	0.91	2.13	0.00	SAL WOOD FRAME FLUSH DOOR
D3	0.99	2.13	0.00	SAL WOOD FRAME FLUSH DOOR
D4	1.06	2.13	0.00	SAL WOOD FRAME FLUSH DOOR
W1	0.60	1.0	1.13	STEEL FRAME GLAZED SHUTTER
W2	0.99	1.13	1.0	STEEL FRAME GLAZED SHUTTER
W3	1.2	1.37	.76	STEEL FRAME GLAZED SHUTTER
W4	1.50	1.37	.76	STEEL FRAME GLAZED SHUTTER

LAND DETAILS

PROPOSED RESIDENTIAL BUILDING PLAN OF
JANARDHAN PRASAD SAH
 S/O LATE :- SATNARAYAN SAH
 PLOT NO. - 1889 , KHATA NO.- 28/61
 VILLAGE - DUMKA , WARD NO - 19
 THANA NO - 07 , DISTRICT. - DUMKA
 STATE -- JHARKHAND.

Applicant's Signature: _____

SIGNATURE OF LIC. ENGINEER: _____

Building 'A' (JANARDHAN PRASAD SAH)				
Floor Name	Total Built Up Area (Sq.mt)	Proposed FAR Area (Sq.mt)	Total FAR Area (Sq.mt)	Tenent (No.)
Ground Floor	31.54	31.54	31.54	01
First Floor	31.54	31.54	31.54	00
Terrace Floor	0.00	0.00	0.00	00
Total	63.08	63.08	63.08	01
Total Number of Same Buildings	1			
Total	63.08	63.08	63.08	01

SCHEDULE OF JOINERY:				
BUILDING NAME	NAME	LENGTH	HEIGHT	NO.
A (JANARDHAN PRASAD SAH)	D1	0.92	2.13	02
Total				02

SCHEDULE OF JOINERY:				
BUILDING NAME	NAME	LENGTH	HEIGHT	NO.
A (JANARDHAN PRASAD SAH)	V	0.60	1.00	02
A (JANARDHAN PRASAD SAH)	W	1.00	2.70	04
Total				06

Unit/BUA Table for Building 'A' (JANARDHAN PRASAD SAH)						
FLOOR	Name	Unit/BUA Type	Unit/BUA Area	Carpet Area	No. of Rooms	No. of Tenement
GROUND FLOOR	SPLIT A	FLAT	30.09	30.05	2	1
TERRACE			30.09	30.05	4	1