

TITEL - PROPOSED B+G+4 STORIED COMMERCIAL BUILDING OF MADARSA COMMITTEE (PRESIDENT SRI MD PERWEZ ALI)

REF 54 DT 10-3-19

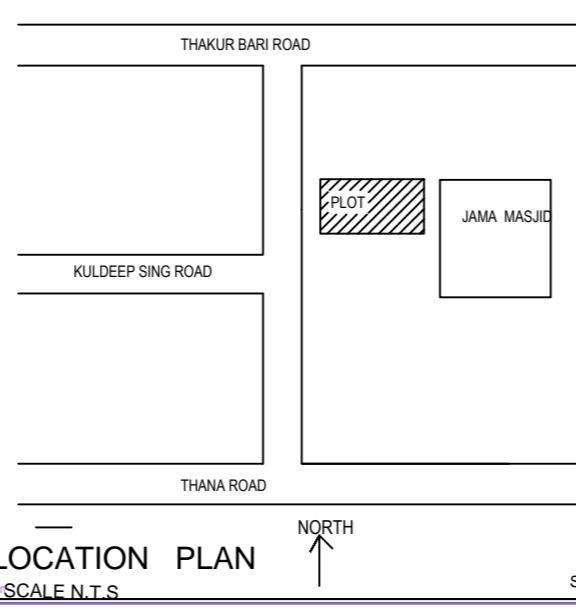
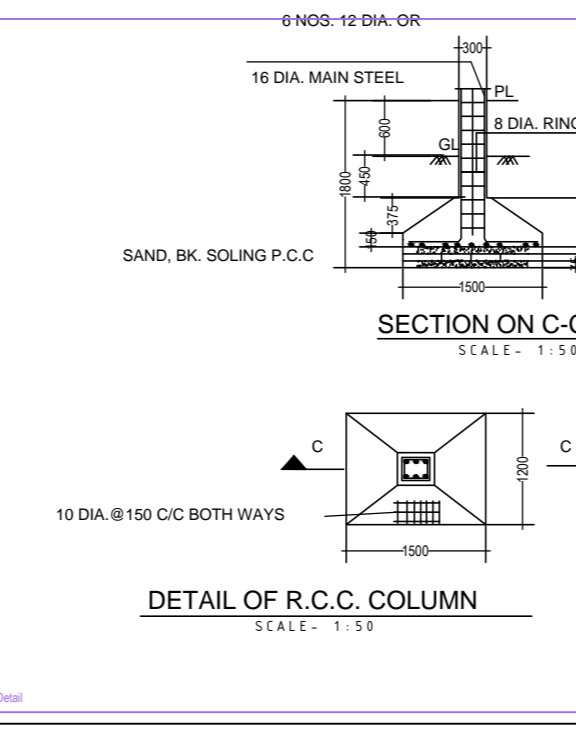
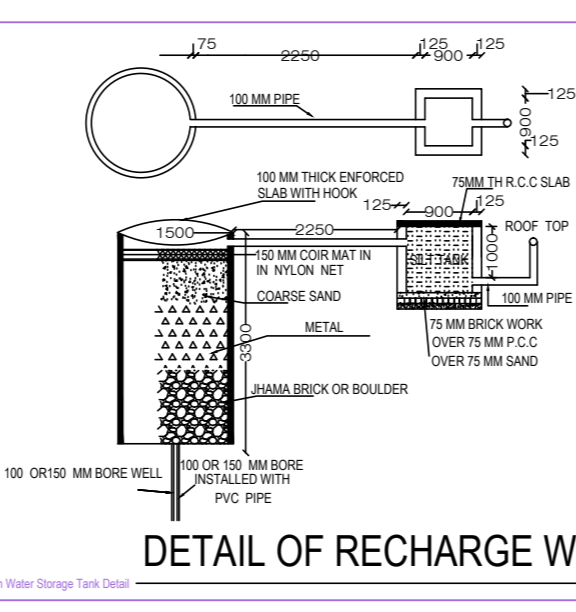
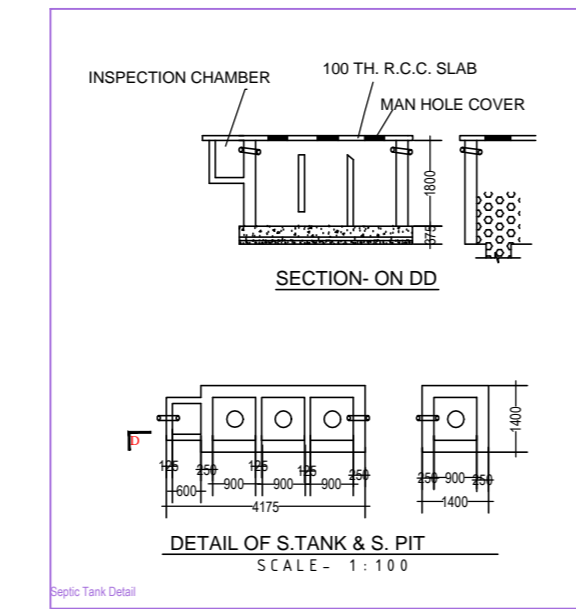
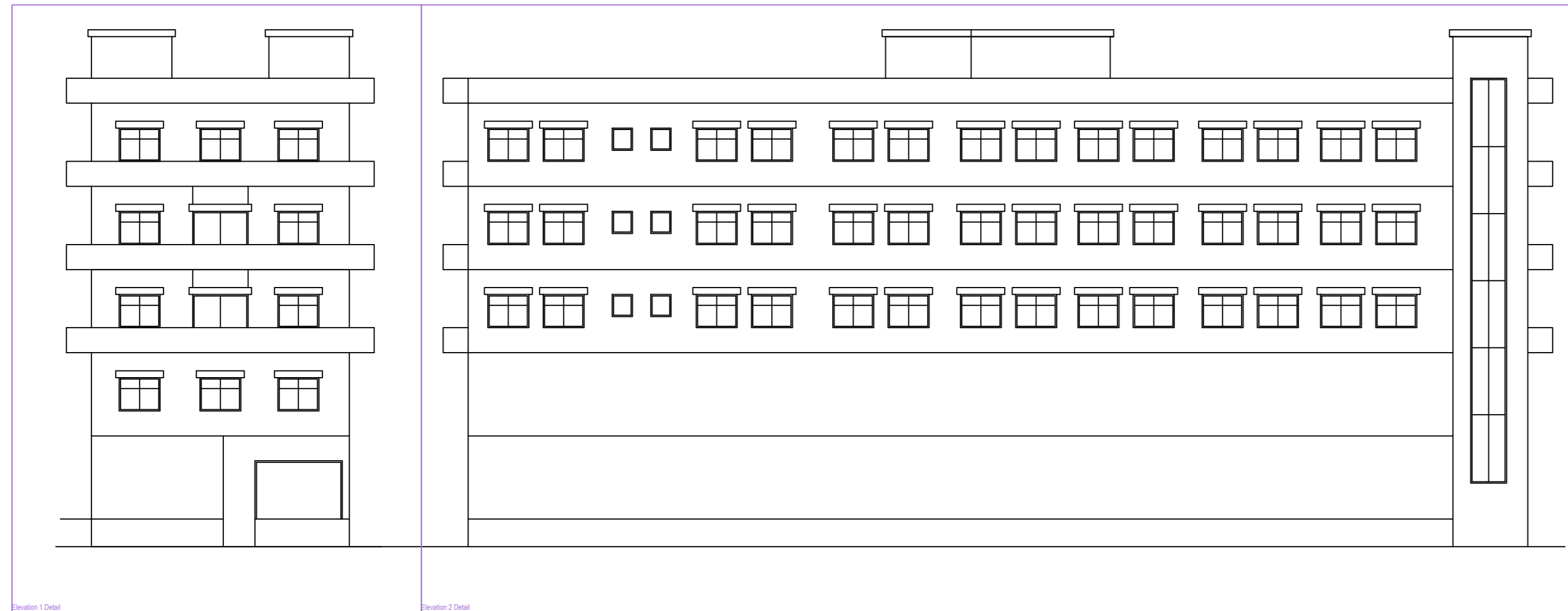
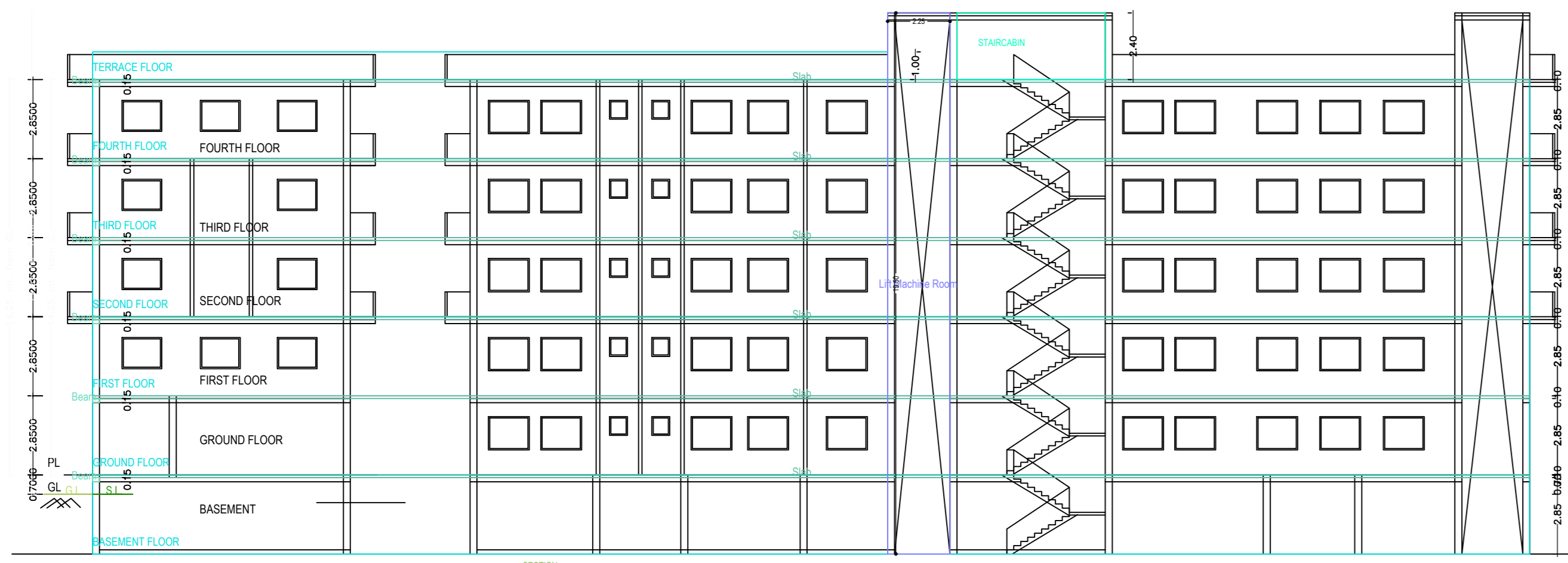

Space for Sanction Authority seal.

SCHEDULE OF AREA table with columns for Plot Area, Ground Floor Area, Total Covered Area, % of Ground Coverage, FAR, and Height of Building.

LAND DETAIL: MOUZA DUMKA TOWN NO-07, PLOT NO. 1510, KHATA NO. 14/3, WARD NO. 13

GENERAL SPECIFICATION: 1. FOUNDATION: R.C.C. Rafting at 30 CM below B.V.L. & R.V.S.D. Ratio, as per design. 2. STRUCTURE: Composite Reinforced Concrete, Slabs, Stairs etc. shall be in M20 concrete & R.V.S.D. Reinforcement as per design.

SCHEDULE OF OPENINGS (In mtrs.): Table with columns for TYPE, WIDTH, HEIGHT, and DESCRIPTION.

TITLE - PROPOSED B+G+4 STORIED COMMERCIAL BUILDING OF MADARSA COMMITTEE (PRESIDENT SRI MD PERWEZ ALI)

CLIENT'S SIGNATURE:

NOTES: ALL DIMENSIONS ARE IN METERS UNLESS SPECIFIED OTHERWISE.

TITEL - PROPOSED B+G+4 STORIED COMMERCIAL BUILDING OF MADARSA COMMITTEE (PRESIDENT SRI MD PERWEZ ALI)

REF 54 DT 10-3-19

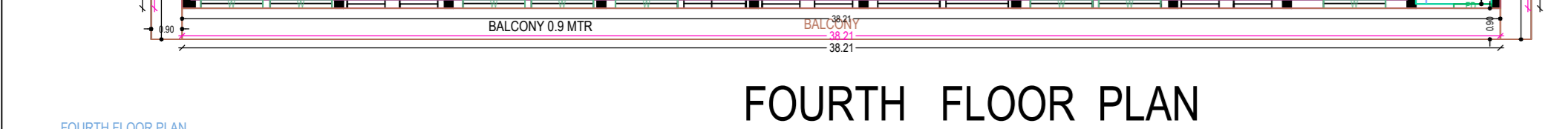
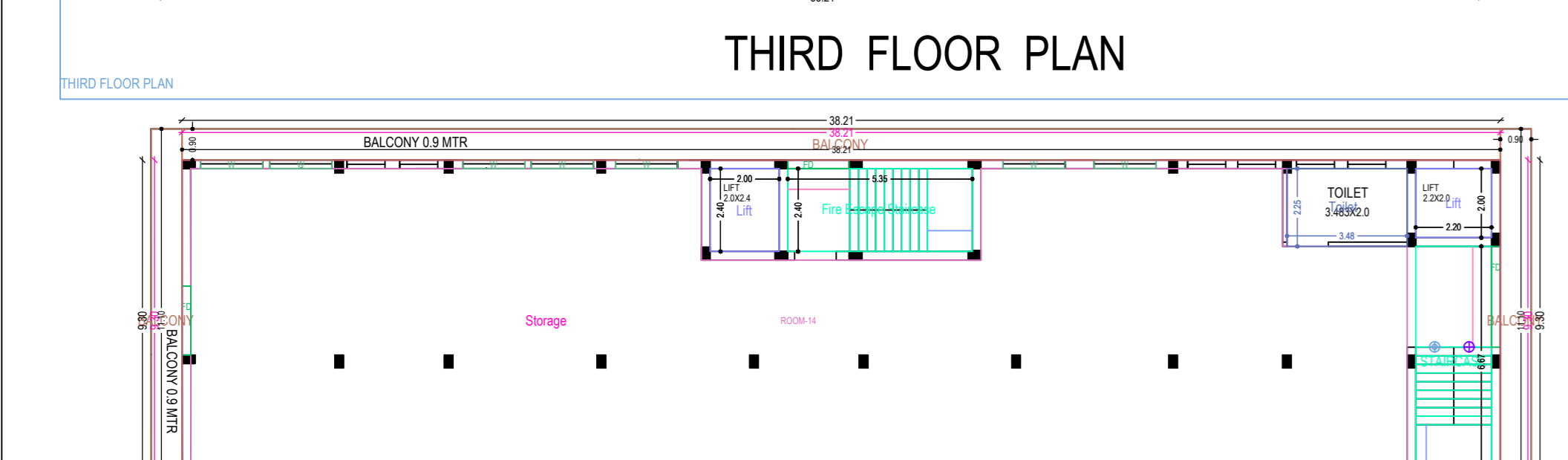
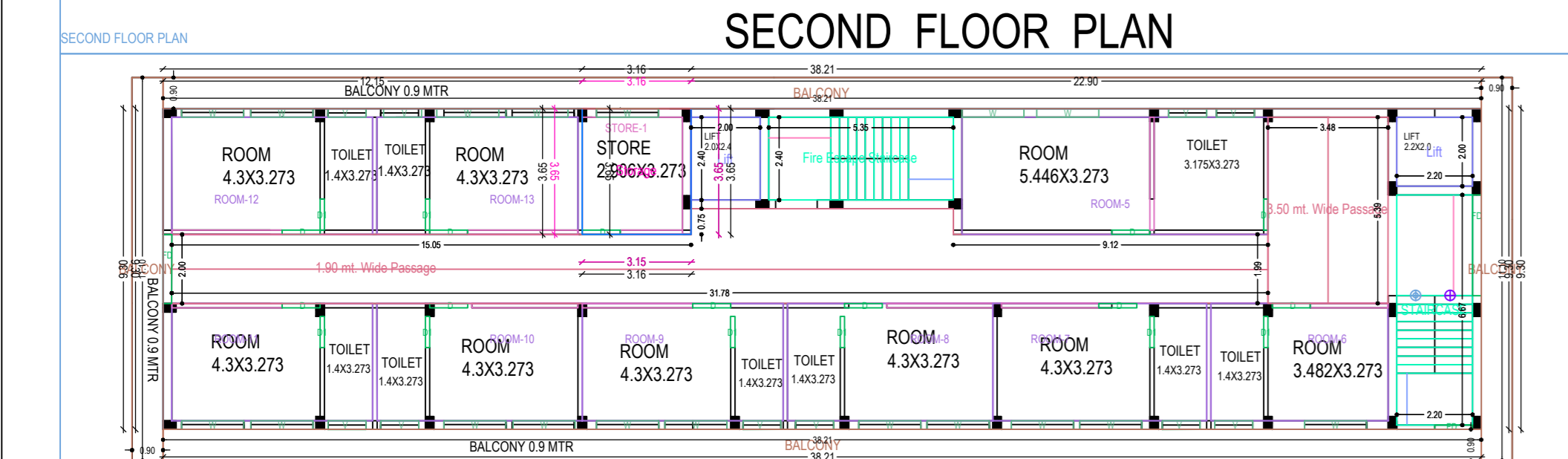
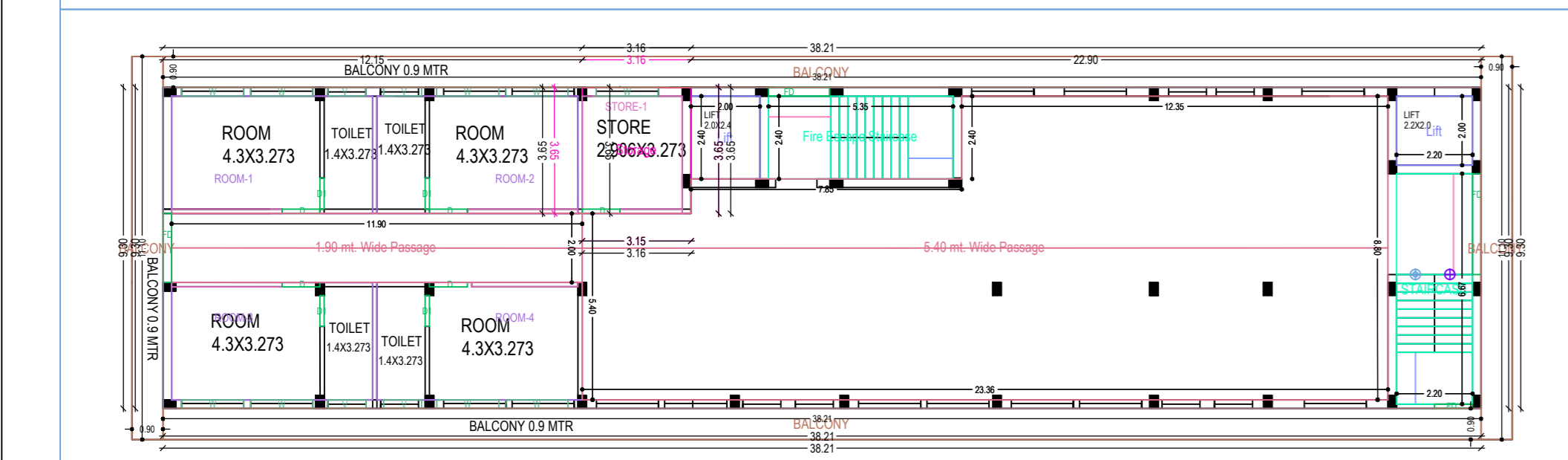
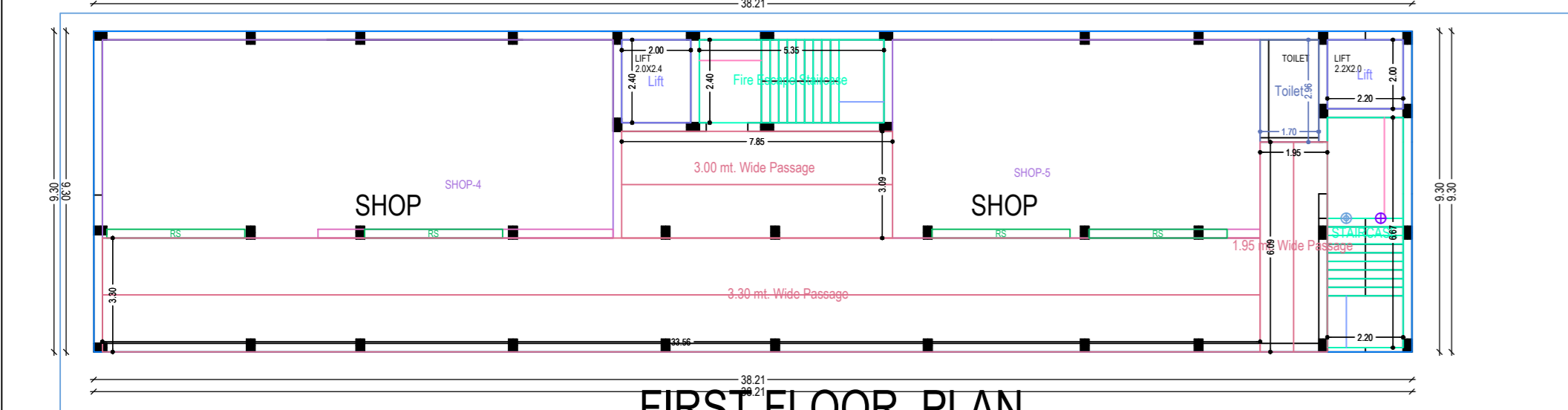

Color Index table with columns for Color Name and Hex Code.

Parking Calculation table with columns for Building, Area, and Capacity.

Basement Margin Detail table with columns for Item, Rate, and Amount.

Building Schedule of Area table with columns for Floor, Area, and Volume.

Space for Sanction Authority seal.

SCHEDULE OF AREA table with columns for Plot Area, Ground Floor Area, Total Covered Area, % of Ground Coverage, FAR, and Height of Building.

LAND DETAIL: MOUZA DUMKA TOWN NO-07, PLOT NO. 1510, KHATA NO. 14/3, WARD NO. 13

GENERAL SPECIFICATION: 1. FOUNDATION: R.C.C. Rafting at 30 CM below B.V.L. & R.V.S.D. Ratio, as per design. 2. STRUCTURE: Composite Reinforced Concrete, Slabs, Stairs etc. shall be in M20 concrete & R.V.S.D. Reinforcement as per design.

SCHEDULE OF OPENINGS (In mtrs.): Table with columns for TYPE, WIDTH, HEIGHT, and DESCRIPTION.

TITLE - PROPOSED B+G+4 STORIED COMMERCIAL BUILDING OF MADARSA COMMITTEE (PRESIDENT SRI MD PERWEZ ALI)

CLIENT'S SIGNATURE:

NOTES: ALL DIMENSIONS ARE IN METERS UNLESS SPECIFIED OTHERWISE.

TITEL - PROPOSED B+G+4 STORIED COMMERCIAL BUILDING OF MADARSA COMMITTEE (PRESIDENT SRI MD PERWEZ ALI)

REF 54 DT 10-3-19

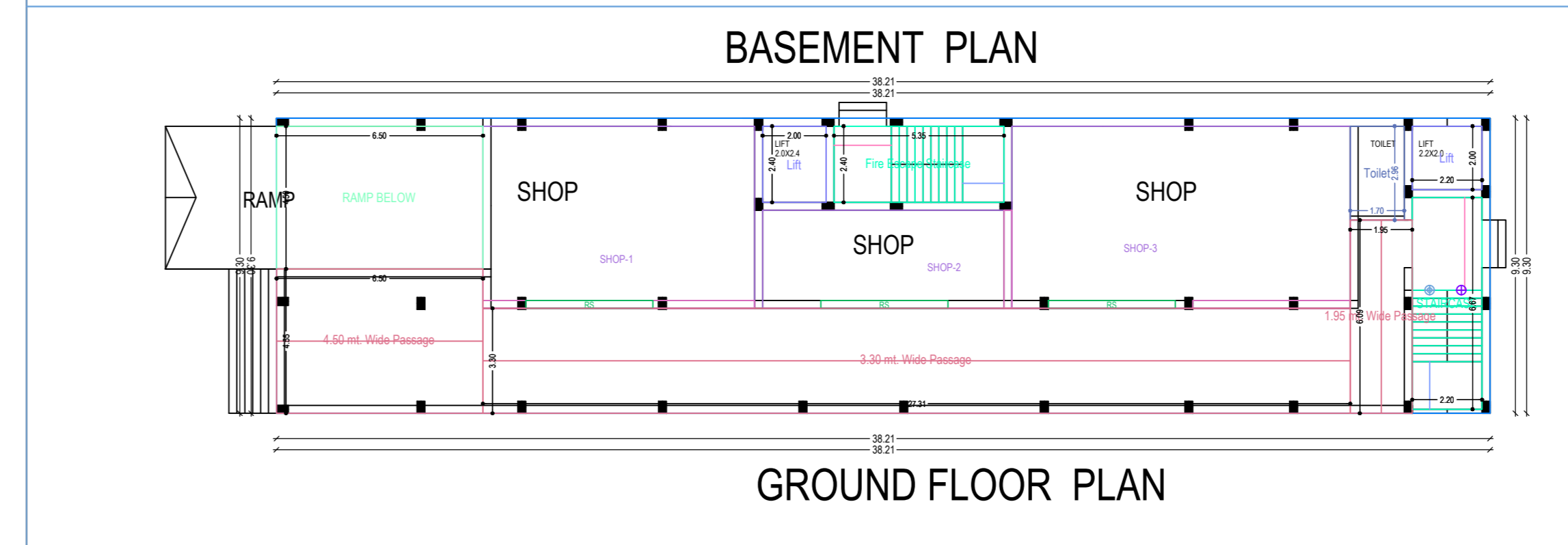
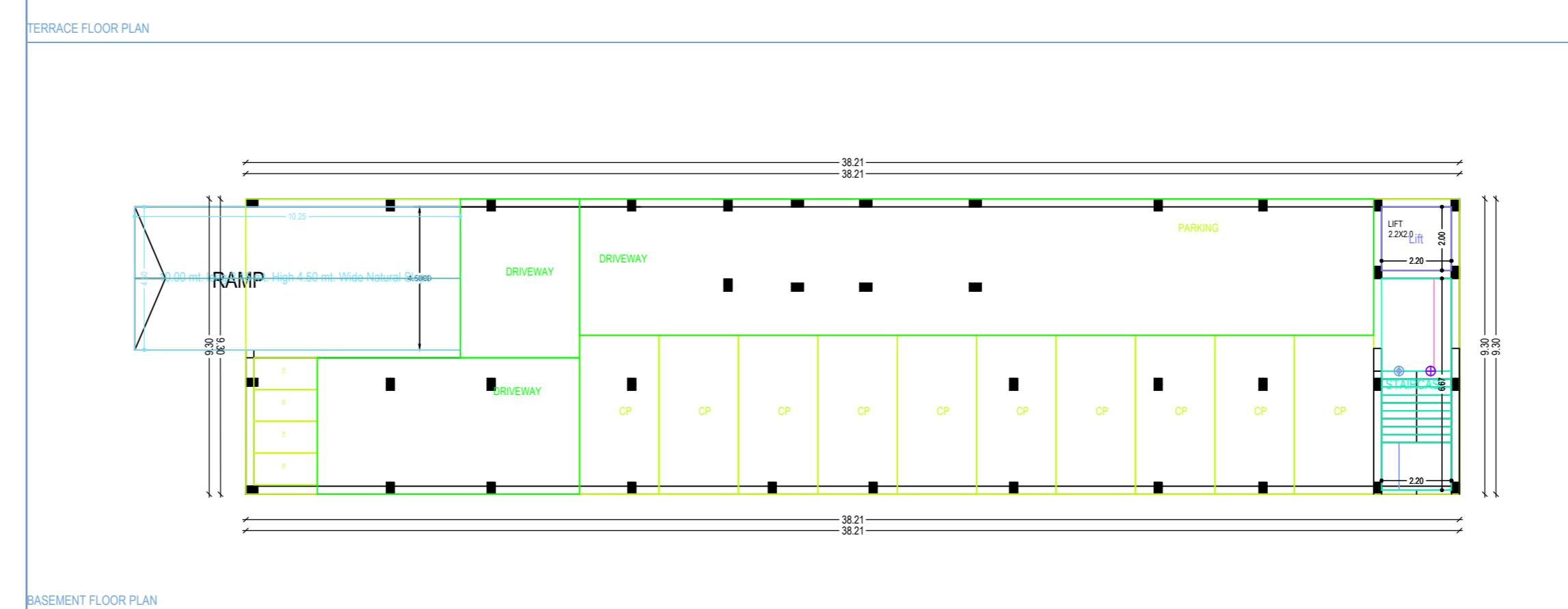
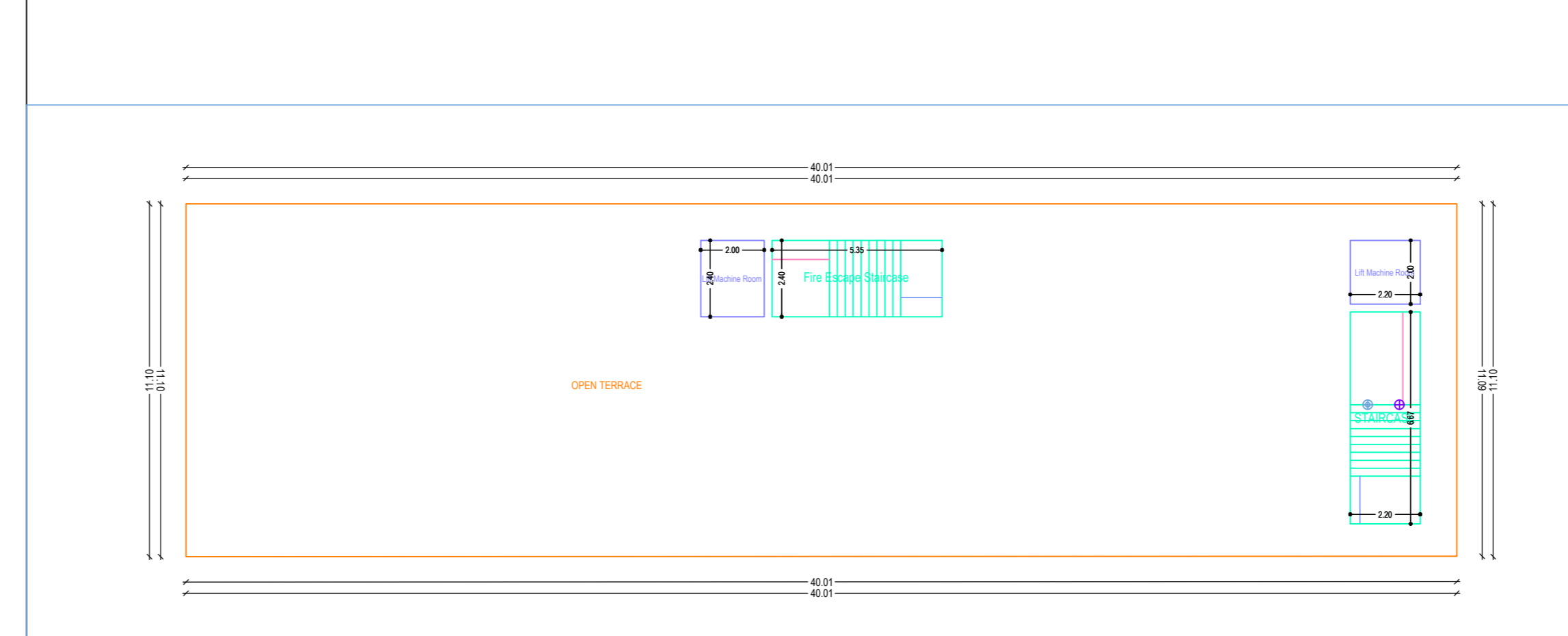

Building Schedule of Area table with columns for Floor, Area, and Volume.

SCHEDULE OF JOINTS: Table with columns for Joint Name, Length, Height, and No.

General Specification: 1. FOUNDATION: R.C.C. Rafting at 30 CM below B.V.L. & R.V.S.D. Ratio, as per design.

LAND DETAIL: MOUZA DUMKA TOWN NO-07, PLOT NO. 1510, KHATA NO. 14/3, WARD NO. 13

GENERAL SPECIFICATION: 1. FOUNDATION: R.C.C. Rafting at 30 CM below B.V.L. & R.V.S.D. Ratio, as per design. 2. STRUCTURE: Composite Reinforced Concrete, Slabs, Stairs etc. shall be in M20 concrete & R.V.S.D. Reinforcement as per design.

SCHEDULE OF OPENINGS (In mtrs.): Table with columns for TYPE, WIDTH, HEIGHT, and DESCRIPTION.

TITLE - PROPOSED B+G+4 STORIED COMMERCIAL BUILDING OF MADARSA COMMITTEE (PRESIDENT SRI MD PERWEZ ALI)

CLIENT'S SIGNATURE:

NOTES: ALL DIMENSIONS ARE IN METERS UNLESS SPECIFIED OTHERWISE.