

Proposal Basic Information	
Proposal File No.	DNP/BB/0013/W10/2020
Owner Name	KANCHAN DEVI
Khata No	10/8/ZAND 10/8/3
Plot No	510
Village Name	Dumka Town
Use	Residential
SubUse	Residential Bldg/Apartment

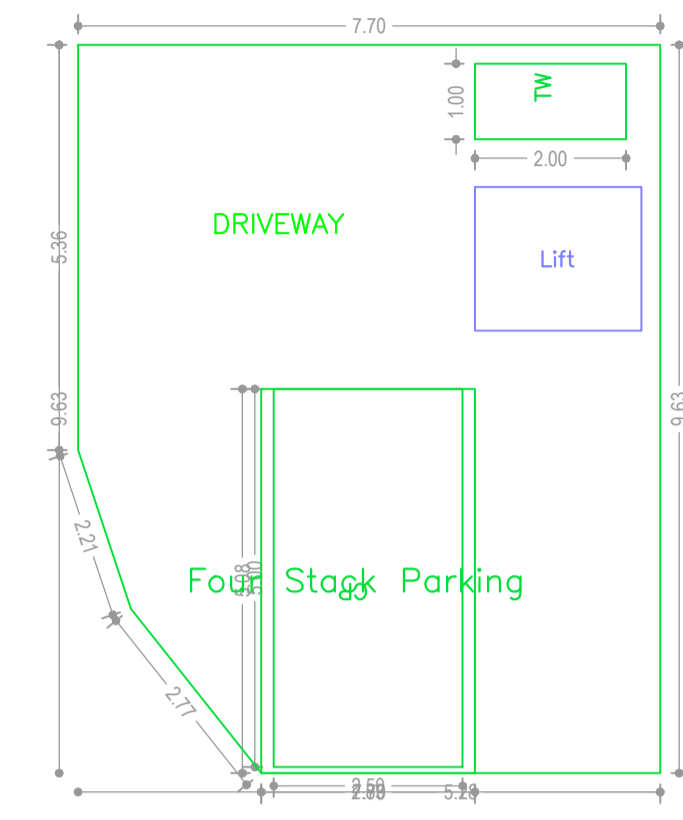
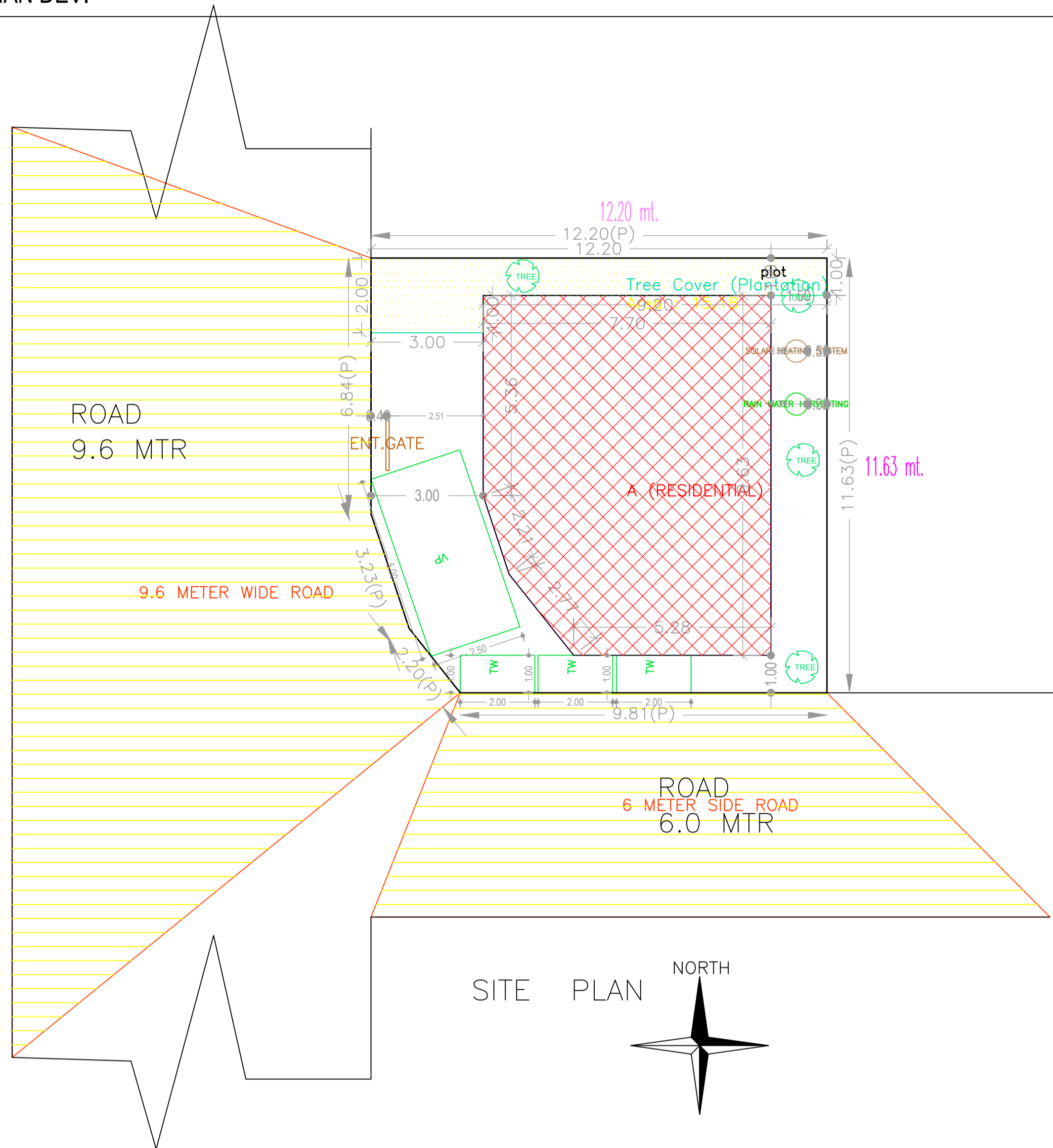

BASEMENT FLOOR PLAN (SCALE 1:100)

AREA STATEMENT DUMKA NAGAR PARISHAD		VERSION NO. : 1.0.50
PROJECT DETAIL:		VERSION DATE: 16/10/2020
Region: JHARKHAND URBAN LOCAL BODIES	Plot Use: Residential	
District: DUMKA	Plot SubUse: Residential Bldg/Apartment	
Authority: DUMKA NAGAR PARISHAD	PlotNearby/ReligiousStructure: NA	
Inward No: DNP/BB/0013/W10/2020	Plot/SubPlot No: 510	
Application Type: General Proposal	North: Plot No. - 510	
Project Type: Building Permission	South: Road Width - 6.00	
Nature of Development: New	East: Plot No. - 510	
Location of Development Area: Old Area	West: Road Width - 9.6	
AREA DETAILS:		SQ.MT.
AREA OF PLOT (Minimum)	(A)	137.40
NET AREA OF PLOT(Gross Plot Area - Deduction from Gross Plot area)	(A-Deductions)	137.40
Deduction for Balance Plot Area(from Gross Plot Area)		
Common Plot		15.18
Total		15.18
BALANCE AREA OF PLOT(Net Plot Area - Recreational/Amenity space)	(A-Deductions)	122.22
PLOT AREA FOR COVERAGE(Net Plot Area)	(A-Deductions)	137.40
Plot Area for FAR (Net Plot Area + RoadWidening Area)	(A-Deductions)	137.40
COVERAGE CHECK		
Permissible Coverage area (60.00 %)		82.44
Proposed Coverage Area (50.97 %)		70.03
Total Prop. Coverage Area (50.97 %)		70.03
Balance coverage area (9.03 %)		12.41
FAR CHECK		
Perm. FAR Area (2.50)		343.50
Total Perm. FAR area		343.50
Residential FAR		295.38
Proposed FAR Area		295.38
Total Proposed FAR Area		295.38
Consumed FAR (Factor)		2.15
Balance FAR Area		48.12
BUILT UP AREA CHECK		
Total Proposed BuiltUp Area		377.96
ARCHITECT (Regd)		SURJYA CHOUDHURY
ENGINEER (Regd)		
SUPERVISOR (Regd)		
OWNER (Regd)		KANCHAN DEVI
DEVELOPMENT AUTHORITY		LOCAL BODY

SITE PLAN

Buildingwise Floor FAR Details

Floor Name	Building Name A (RESIDENTIAL)		Total	
	Proposed Built Up Area (Sq.mt.)	Proposed FAR Area (Sq.mt.)	Total Proposed Built Up Area (Sq.mt.)	Total FAR Area (Sq.mt.)
Basement Floor	70.03	0.00	70.03	0.00
Ground Floor	70.03	70.03	70.03	70.03
First Floor	79.30	75.12	79.30	75.12
Second Floor	79.30	75.12	79.30	75.12
Third Floor	79.30	75.12	79.30	75.12
Terrace Floor	0.00	0.00	0.00	0.00
Total :	377.96	295.39	377.96	295.39

FAR & Tenement Details (Table 4c-1)

Building	No. of Same Bldg	Total Built Up Area (Sq.mt.)	Deductions (Area in Sq.mt.)		Proposed FAR Area (Sq.mt.)	Total FAR Area (Sq.mt.)	Total Consumed Additional FAR Area (Sq.mt.)	Tnmt (No.)
			Lift	Parking				
A (RESIDENTIAL)	1	377.96	16.72	65.85	295.39	295.39	295.39	04
Grand Total :	1	377.96	16.72	65.85	295.39	295.39	295.39	04

Building USE/SUBUSE Details

Building Name	Building Use	Building SubUse	Building Structure
A (RESIDENTIAL)	Residential	Residential Bldg/Apartment	Non-Highrise

Required Parking(Table 7a)

Building Name	Type	SubUse	Area (Sq.mt.)	Units		Car		Visitors Car		TwoWheeler			
				Reqd.	Prop.	Reqd./Unit	Reqd.	Prop.	Reqd./Unit	Reqd.	Prop.	Reqd./Unit	Reqd.
A (RESIDENTIAL)	Residential	Residential Bldg/Apartment	> 0	1	4.00	-	-	-	-	-	-	-	
				1	4.00	-	-	-	-	-	1	4	-
Total :			-	-	-	4	4	-	1	1	-	4	4

Parking Check (Table 7b)

Vehicle Type	Reqd.		Prop.	
	No.	Area	No.	Area
Car	-	-	1	12.50
Four Stack.Car	-	-	3	37.50
Total Car	4	50.00	4	50.00
Visitor's Car Parking	-	-	1	12.50
Total Visitor Parking	1	12.50	1	12.50
TwoWheeler	-	-	4	8.00
Total TwoWheeler	4	8.00	4	8.00
Other Parking	-	-	-	51.35
Total	-	70.50	-	129.85

COLOR INDEX

PLOT BOUNDARY	Black
ABUTTING ROAD	Green
PROPOSED CONSTRUCTION	Red
COMMON PLOT	Yellow
ROAD WIDENING AREA	Orange
EXISTING (To be retained)	Blue
EXISTING (To be demolished)	Light Blue

LTP NAME AND SIGNATURE	STRUCTURAL ENG'S NAME AND SIGNATURE	BUILDER NAME AND SIGNATURE	DIGITAL SIGNATURE
SURJYA CHOUDHURY DNP/ENG/0002/2018			

Proposal Basic Information	
Proposal File No.	DNP/BP/0013/W10/2020
Owner Name	KANCHAN DEVI
Khata No	10/8/ZAND 10/8/3
Plot No	510
Village Name	Dumka Town
Use	Residential
SubUse	Residential Bldg/Apartment

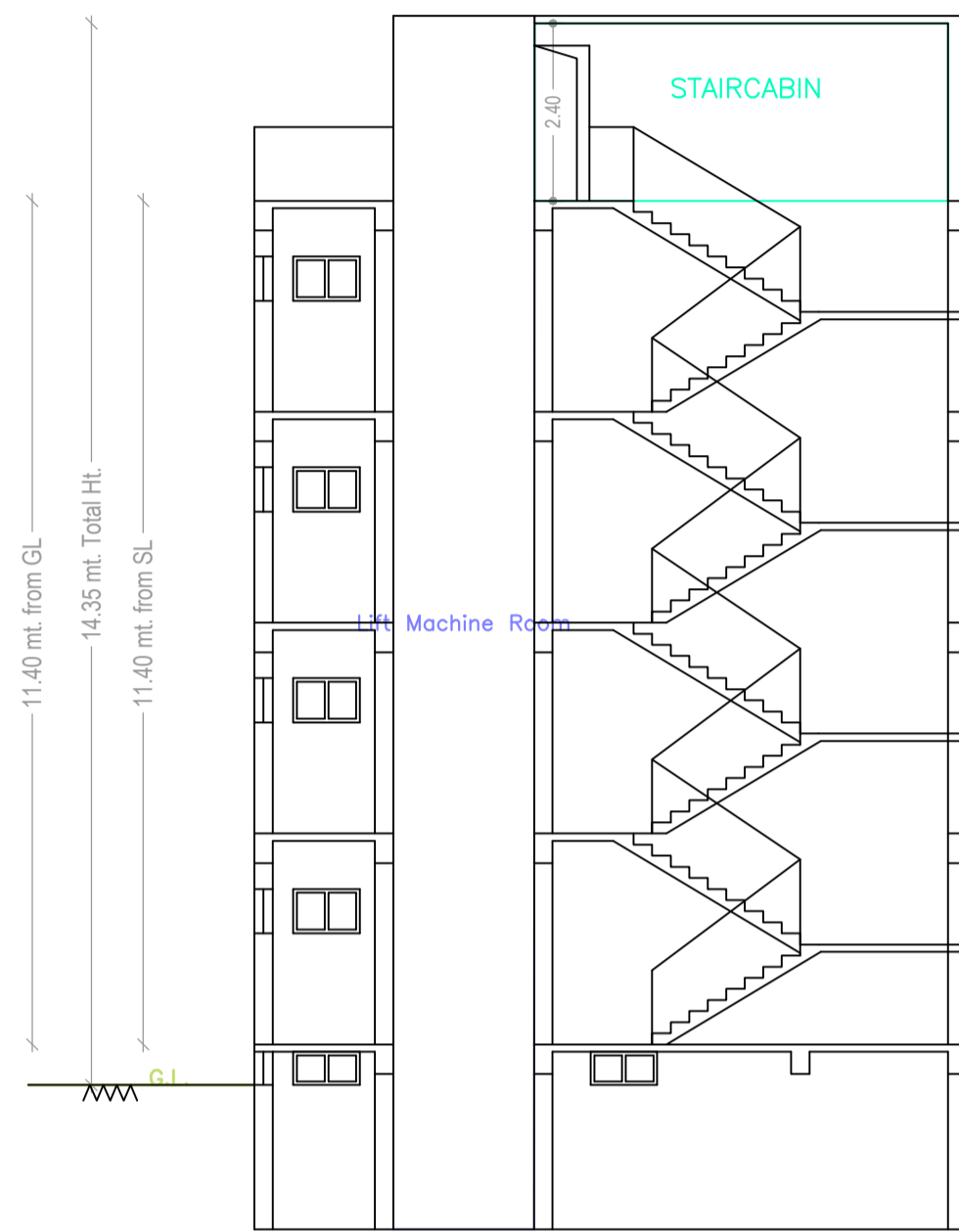

SECTION X-X

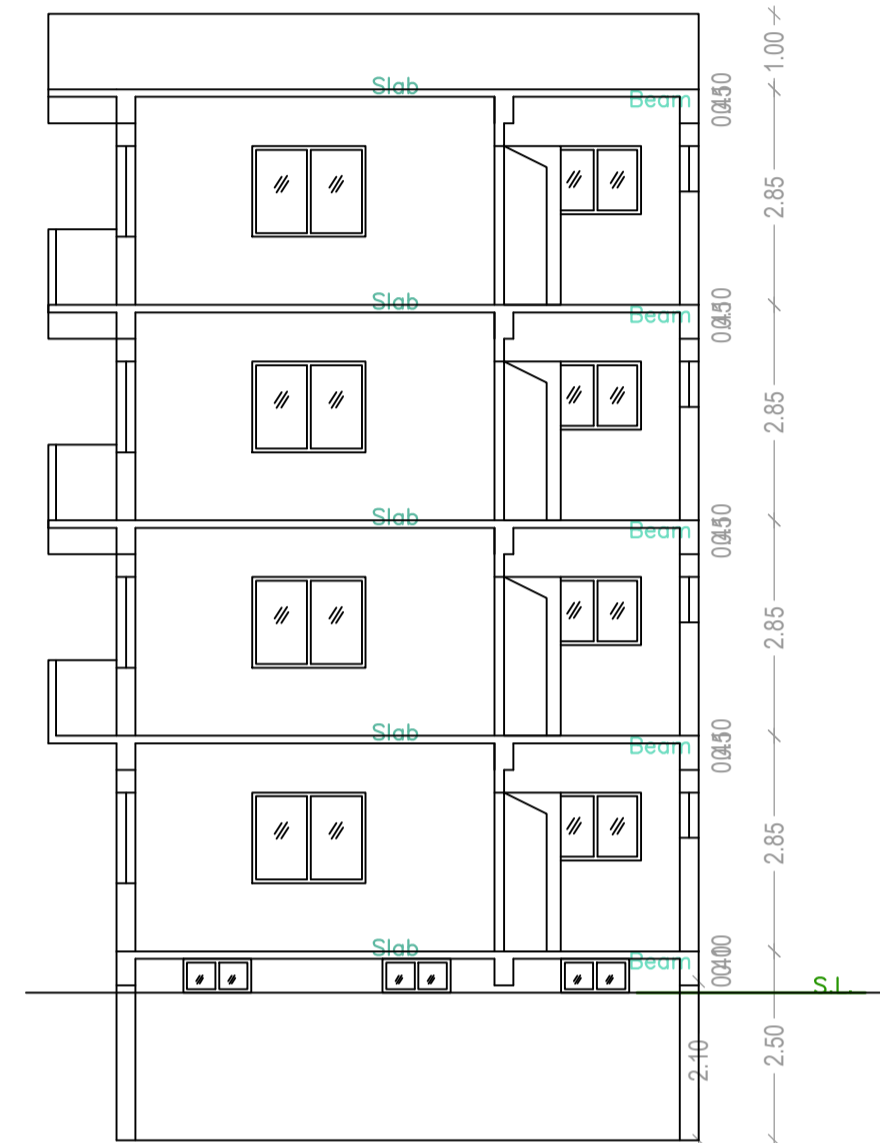

SECTION Y-Y

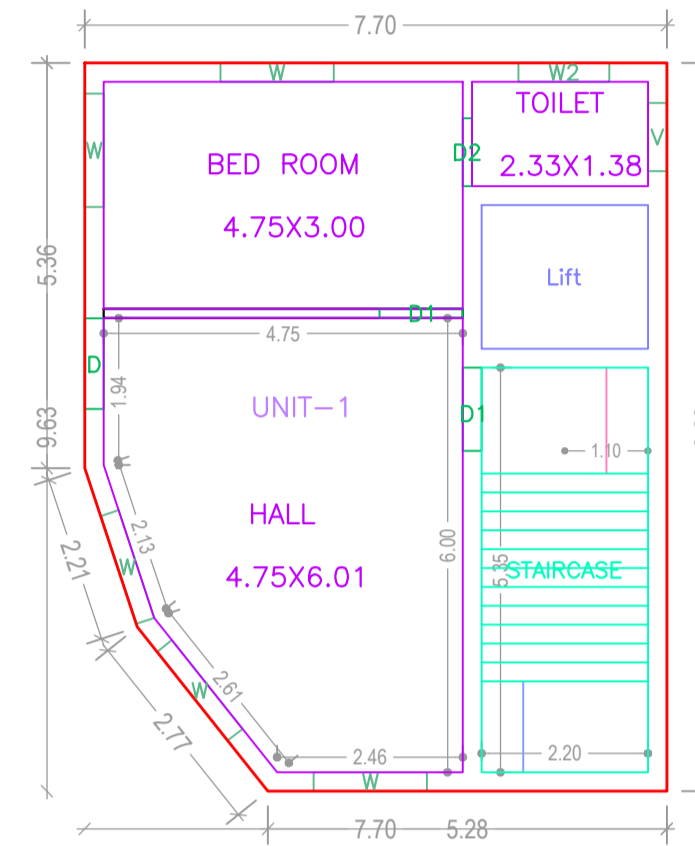

GROUND FLOOR PLAN
(Proposed)
(SCALE 1:100)

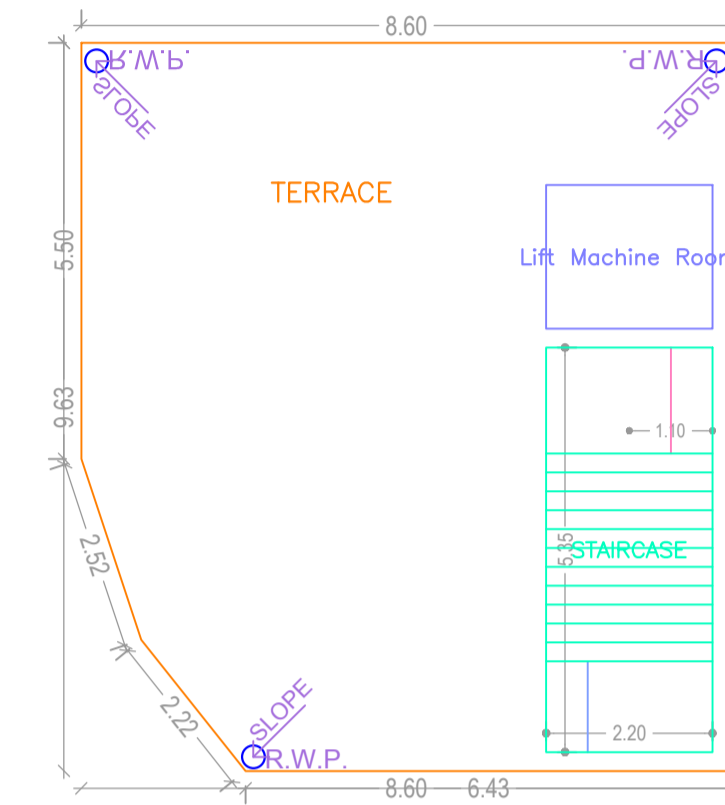

TERRACE FLOOR PLAN
(SCALE 1:100)

Building :A (RESIDENTIAL)

Floor Name	Total Built Up Area (Sq.mt.)	Deductions (Area in Sq.mt.)		Proposed FAR Area (Sq.mt.)	Total FAR Area (Sq.mt.)	Total Consumed Additional FAR Area (Sq.mt.)	Trmt (No.)
		Lift	Parking				
Basement Floor	70.03	4.18	65.85	0.00	0.00	0.00	00
Ground Floor	70.03	0.00	0.00	70.03	70.03	70.03	01
First Floor	79.30	4.18	0.00	75.12	75.12	75.12	01
Second Floor	79.30	4.18	0.00	75.12	75.12	75.12	01
Third Floor	79.30	4.18	0.00	75.12	75.12	75.12	01
Terrace Floor	0.00	0.00	0.00	0.00	0.00	0.00	00
Total :	377.96	16.72	65.85	295.39	295.39	295.39	04
Total Number of Same Buildings	1						
Total :	377.96	16.72	65.85	295.39	295.39	295.39	04

SCHEDULE OF DOOR:

BUILDING NAME	NAME	LENGTH	HEIGHT	NOS
A (RESIDENTIAL)	D2	0.90	2.10	10
A (RESIDENTIAL)	D1	1.10	2.10	08
A (RESIDENTIAL)	D	1.20	2.10	01

SCHEDULE OF WINDOW/VENTILATION:

BUILDING NAME	NAME	LENGTH	HEIGHT	NOS
A (RESIDENTIAL)	V	0.90	0.60	04
A (RESIDENTIAL)	W2	1.20	0.90	07
A (RESIDENTIAL)	W	1.50	1.20	20

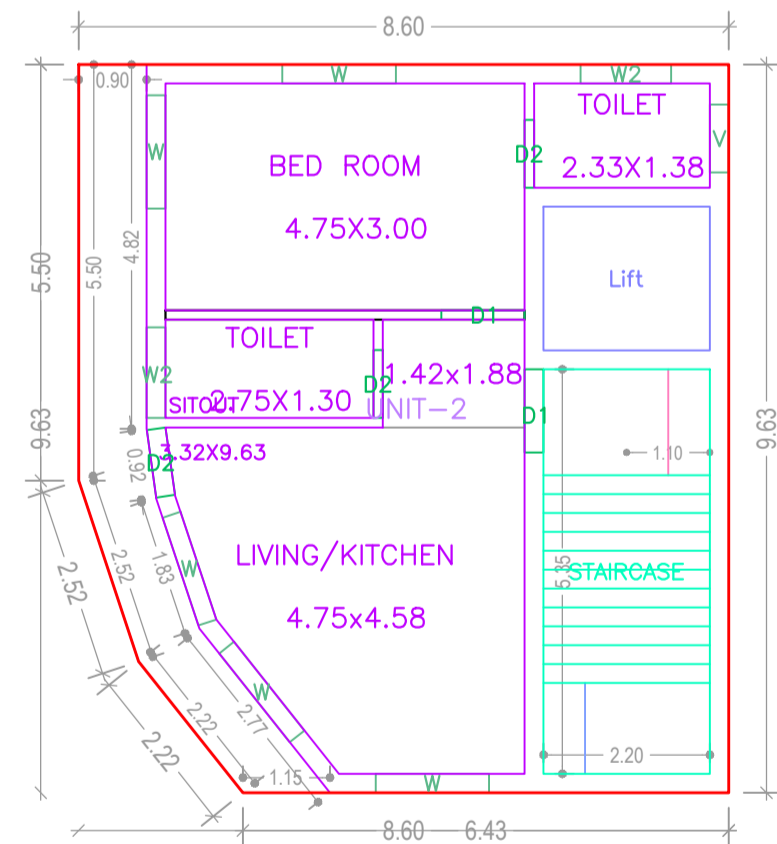

TYPICAL - 1- 3 FLOOR PLAN
(Proposed)
(SCALE 1:100)

UnitBUA Table for Building :A (RESIDENTIAL)

FLOOR	Name	UnitBUA Type	UnitBUA Area	Carpet Area	No. of Rooms	No. of Tenement
GROUND FLOOR PLAN	UNIT-1	FLAT	43.05	42.45	3	1
TYPICAL - 1- 3 FLOOR PLAN	UNIT-2	FLAT	54.81	54.22	5	3
Total:	-	-	207.48	205.10	18	4

LTP NAME AND SIGNATURE	STRUCTURAL ENG'S NAME AND SIGNATURE	BUILDER NAME AND SIGNATURE	DIGITAL SIGNATURE
SURJYA CHOUDHURY DNP/ENG/0002/2018			



Proposal Basic Information	
Proposal File No.	DNP/BP/0013/W10/2020
Owner Name	KANCHAN DEVI
Khata No	10/8/ZAND 10/8/3
Plot No	510
Village Name	Dumka Town
Use	Residential
SubUse	Residential Bldg/Apartment

REINFORCEMENT DETAIL OF FOUNDATION AND COLUMN

COLUMN	FOOTING SIZE IN FT				ZALI	COLUMN SIZE	REINFORCEMENT DETAIL GROUND FLOOR
	L	B	D1	D2			
C1	1.50	2.25	1.7	0.25	375	250X375	REN: 8-16MM STIRRUPS: 8MM @150 C/C
C2	1.70	2.5	1.7	0.25	375	300X375	REN: 4-20MM+16MM STIRRUPS: 8MM @150 C/C

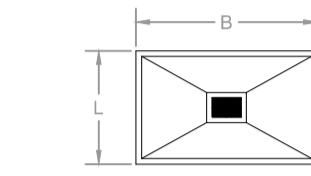
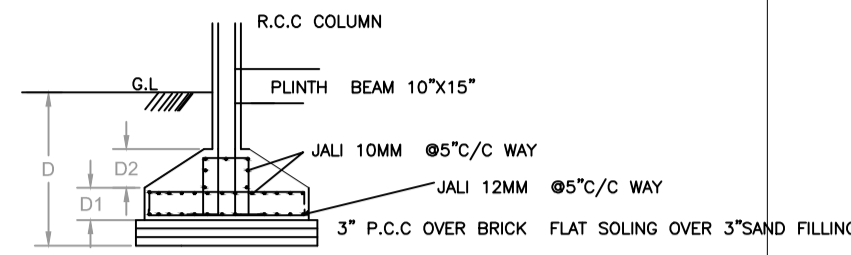

DETAIL OF COL & FOOTING
ISOLATED FOOTING

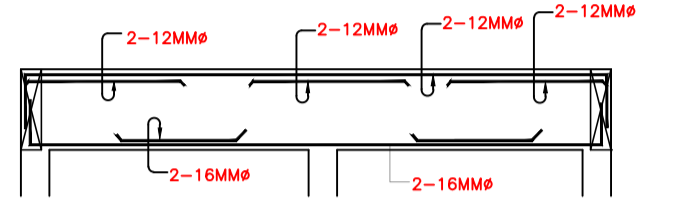

DETAILS OF PLINTH BEAM (250X375)

STRUCTURAL DETAIL

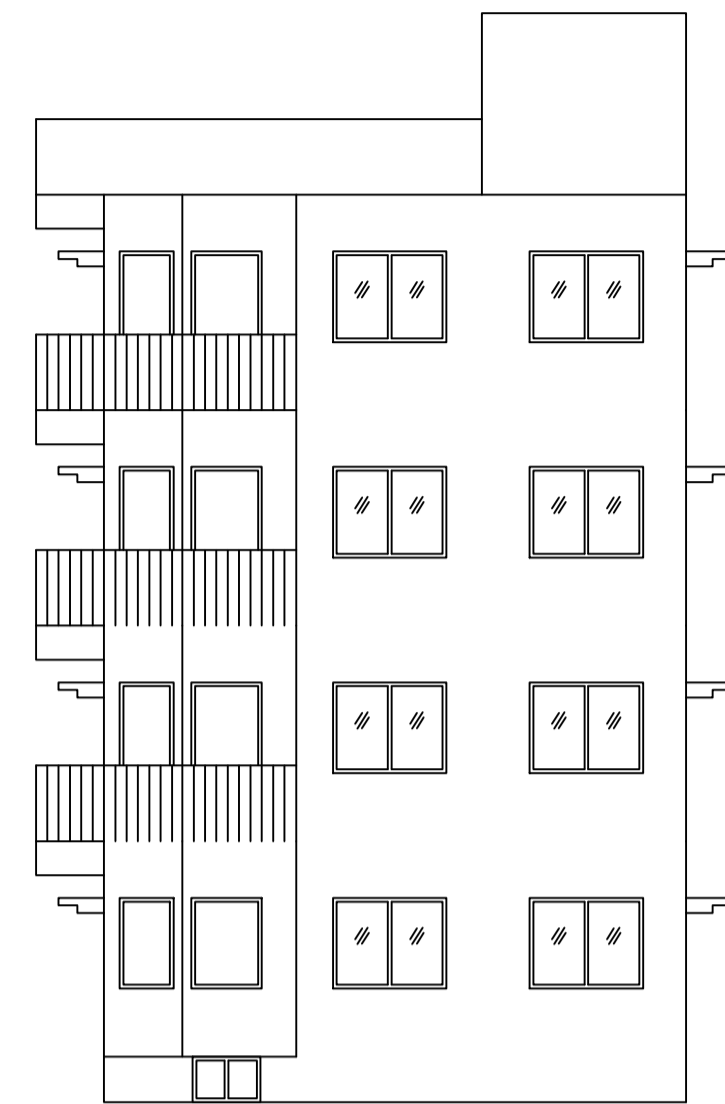

SIDE ELEVATION

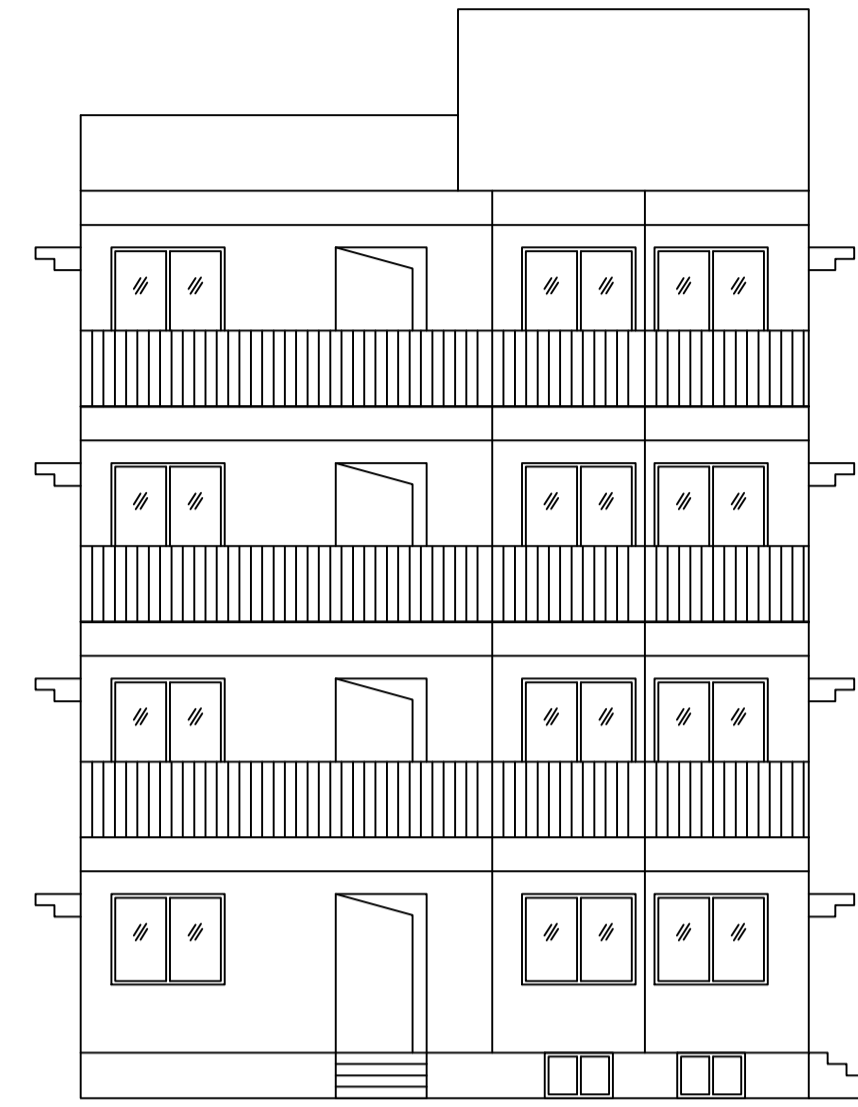

FRONT ELEVATION

THIS IS TO CERTIFY THAT THE STRUCTURE DESIGN OF THE BUILDING WILL BE AS PER I.S. 1893/1984 & 4326/1993 MAKE THE SAME EARTH QUAKE RESISTANT

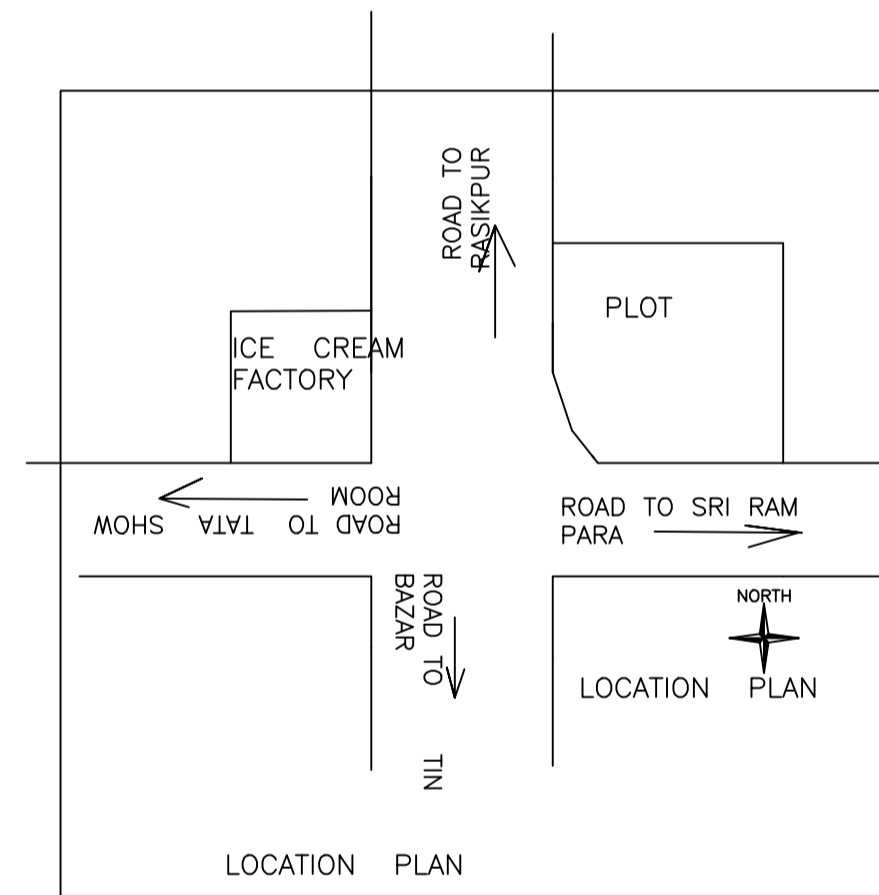

LOCATION PLAN

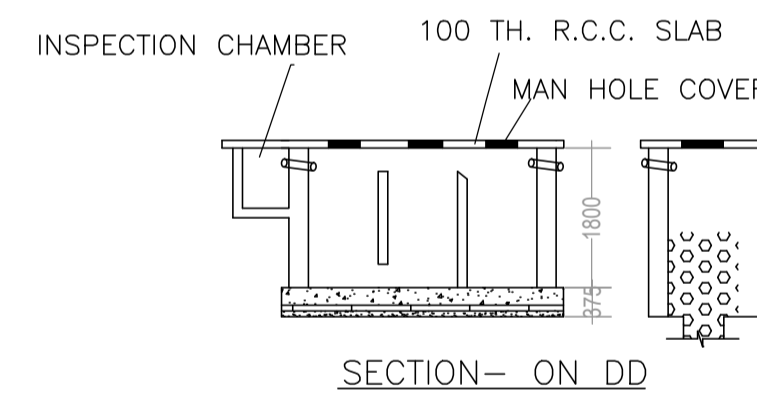

SECTION- ON DD

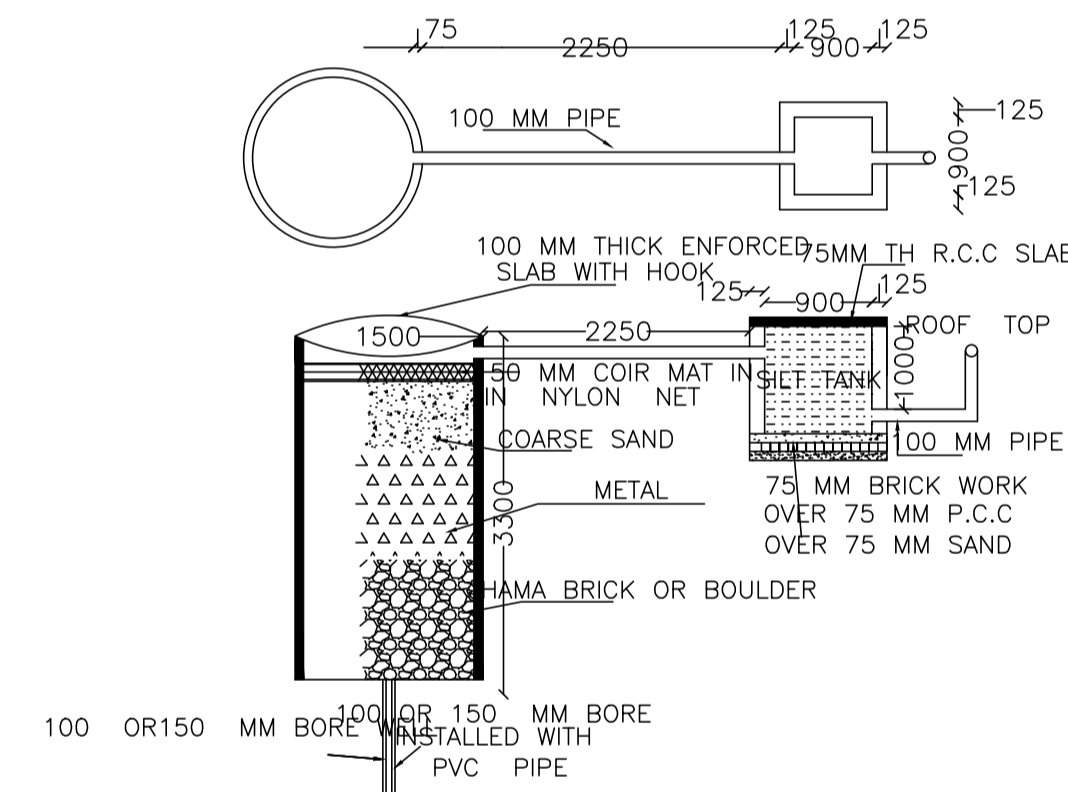

DETAIL OF RECHARGE WELL

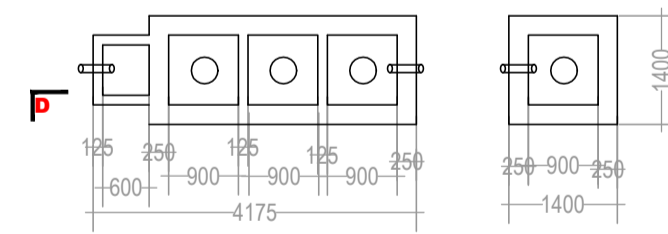

DETAIL OF S.TANK & S. PIT
SCALE- 1:100

LTP NAME AND SIGNATURE	STRUCTURAL ENG'S NAME AND SIGNATURE	BUILDER NAME AND SIGNATURE	DIGITAL SIGNATURE
SURJYA CHOUDHURY DNP/ENG/0002/2018			