

COLOR INDEX	
PLOT BOUNDARY	Black
ABUTTING ROAD	Green
PROPOSED CONSTRUCTION	Red
COMMON PLOT	Yellow
ROAD WIDENING AREA	Orange
EXISTING (To be retained)	Blue
EXISTING (To be demolished)	Light Blue

FAR & Tenement Details (Table 4c-1)

Building	No. of Same Bldg	Total Built Up Area (Sq.mt.)	Proposed FAR Area (Sq.mt.) Resi.	Total FAR Area (Sq.mt.)	Total Consumed Additional FAR Area (Sq.mt.)	Tnmt (No.)
A (RESIDENTIAL)	1	112.50	112.50	112.50	112.50	01
Grand Total :	1	112.50	112.50	112.50	112.50	01

Proposal Basic Information

Proposal File No.	DNP/BP/0003/W21/2020
Owner Name	SMT SITA DEVI
Khata No	32/4/3
Plot No	771&772 PART
Village Name	Dumka Town
Use	Residential
SubUse	Bungalow/ Dwelling / Non Apartment

AREA STATEMENT DUMKA NAGAR PARISHAD		VERSION NO. : 1.0.43
PROJECT DETAIL:		VERSION DATE: 29/04/2019
Region: JHARKHAND URBAN LOCAL BODIES	Plot Use: Residential	
District: DUMKA	Plot SubUse: Bungalow/ Dwelling / Non Apartment	
Authority: DUMKA NAGAR PARISHAD	PlotNearbyReligiousStructure: NA	
Inward_No: DNP/BP/0003/W21/2020	Plot/SubPlot No: 771&772 PART	
Application Type: General Proposal	North: Plot No. - 771&772	
Project Type: Building Permission	South: Plot No. - 771&772	
Nature of Development: New	East: Plot No. - 771&772	
Location of Development Area: Old Area	West: Road Width - 6.4	
AREA DETAILS:		SQ.MT.
AREA OF PLOT (Minimum)	(A)	100.28
NET AREA OF PLOT(Gross Plot Area - Deduction from Gross Plot area)	(A-Deductions)	100.28
Deduction for Balance Plot Area(from Gross Plot Area)		
Common Plot		11.31
Total		11.31
BALANCE AREA OF PLOT(Net Plot Area - Recreational/Amenity space)	(A-Deductions)	88.97
PLOT AREA FOR COVERAGE(Net Plot Area)	(A-Deductions)	100.28
Plot Area for FAR (Net Plot Area + RoadWidening Area)	(A-Deductions)	100.28
COVERAGE CHECK		
Permissible Coverage area (70.00 %)		70.20
Proposed Coverage Area (56.09 %)		56.25
Total Prop. Coverage Area (56.09 %)		56.25
Balance coverage area (13.91 %)		13.95
FAR CHECK		
Perm. FAR Area (2.50)		250.70
Total Perm. FAR area		250.70
Residential FAR		112.50
Proposed FAR Area		112.50
Total Proposed FAR Area		112.50
Consumed FAR (Factor)		1.12
Balance FAR Area		138.20
BUILT UP AREA CHECK		
Total Proposed BuiltUp Area		112.50
ARCHITECT (Regd)		SARAT CHANDRA PANJIYARA
ENGINEER (Regd)		
SUPERVISOR (Regd)		
OWNER (Regd)		SMT SITA DEVI
DEVELOPMENT AUTHORITY		LOCAL BODY

Buildingwise Floor FAR Details

Floor Name	Building Name		Total	
	Proposed Built Up Area (Sq.mt.)	Proposed FAR Area (Sq.mt.)	Total Proposed Built Up Area (Sq.mt.)	Total FAR Area (Sq.mt.)
Ground Floor	56.25	56.25	56.25	56.25
First Floor	56.25	56.25	56.25	56.25
Terrace Floor	0.00	0.00	0.00	0.00
Total :	112.50	112.50	112.50	112.50

Building USE/SUBUSE Details

Building Name	Building Use	Building SubUse	Building Structure
A (RESIDENTIAL)	Residential	Bungalow/ Dwelling / Non Apartment	Non-Highrise

LTP NAME AND SIGNATURE	STRUCTURAL ENG'S NAME AND SIGNATURE	BUILDER NAME AND SIGNATURE	DIGITAL SIGNATURE
SARAT CHANDRA PANJIYARA DNP/SUP/0002/2016			

Proposal Basic Information	
Proposal File No.	DNP/BP/0003/W21/2020
Owner Name	SMT SITA DEVI
Khata No	32/4/3
Plot No	771&772 PART
Village Name	Dumka Town
Use	Residential
SubUse	Bungalow/ Dwelling / Non Apartment

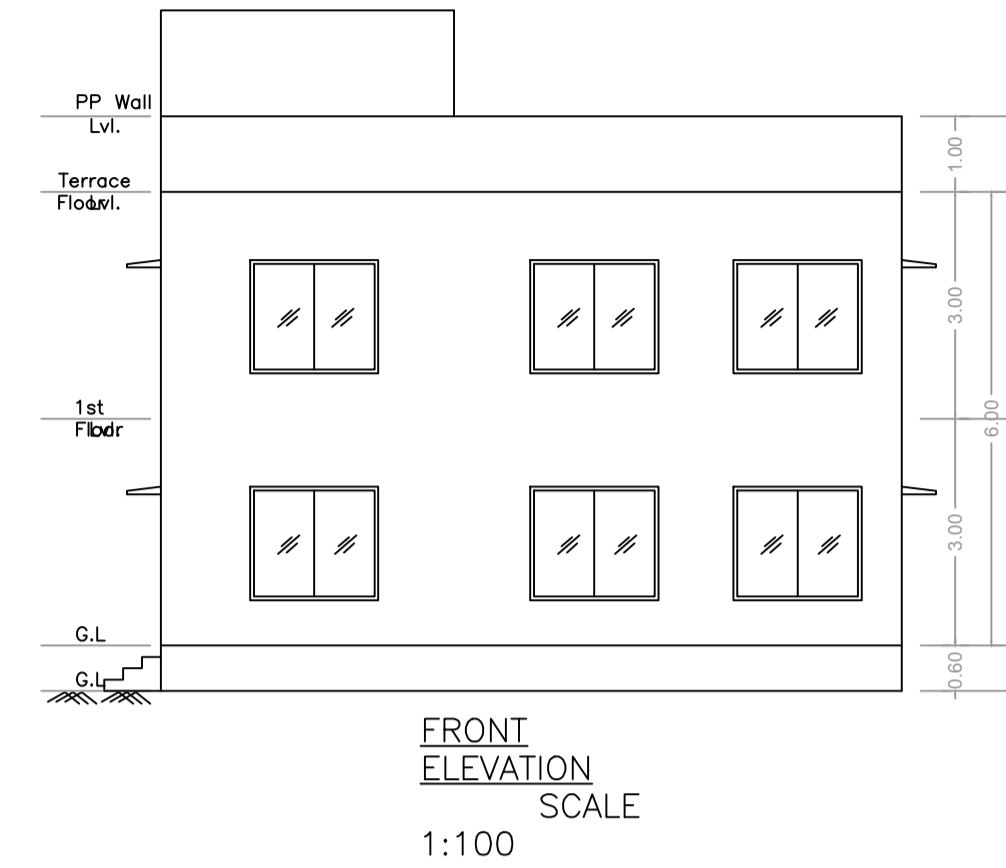
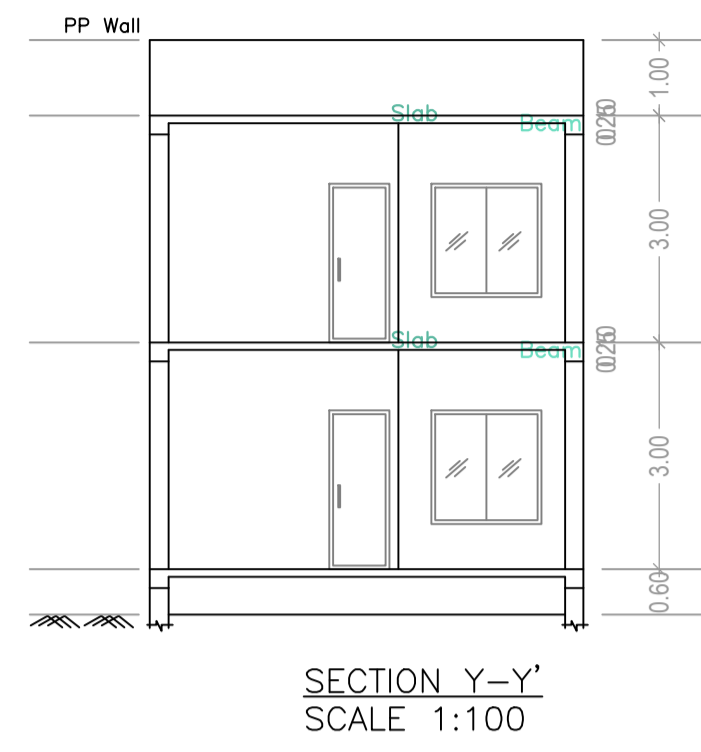
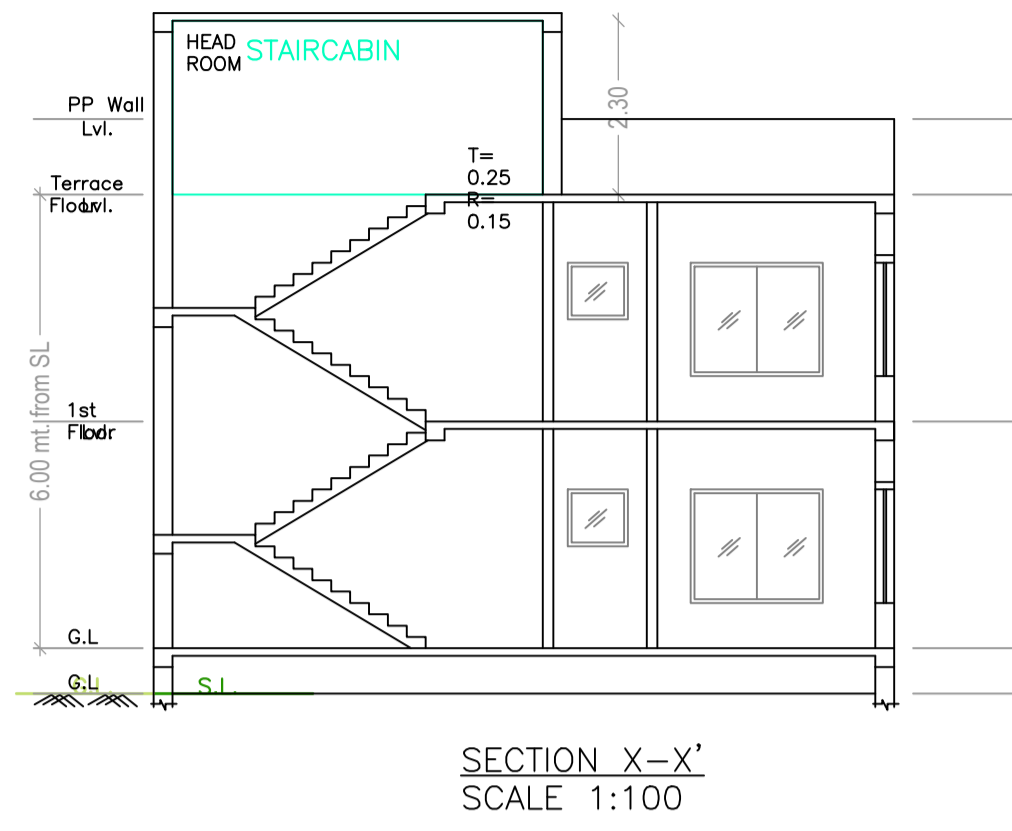

SCHEDULE OF DOOR:

BUILDING NAME	NAME	LENGTH	HEIGHT	NOS
A (RESIDENTIAL)	D1	0.90	2.10	02
A (RESIDENTIAL)	D	1.10	2.10	06

SCHEDULE OF WINDOW/VENTILATION:

BUILDING NAME	NAME	LENGTH	HEIGHT	NOS
A (RESIDENTIAL)	W2	1.00	0.90	02
A (RESIDENTIAL)	W1	1.50	1.20	14

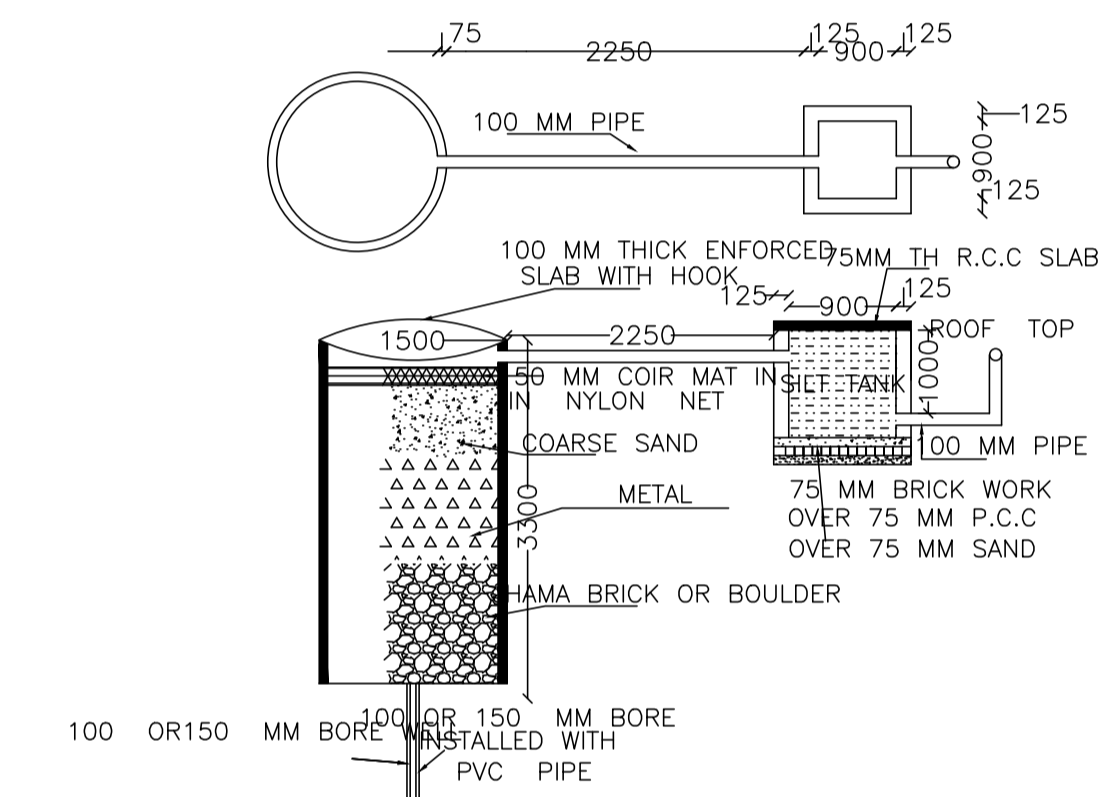
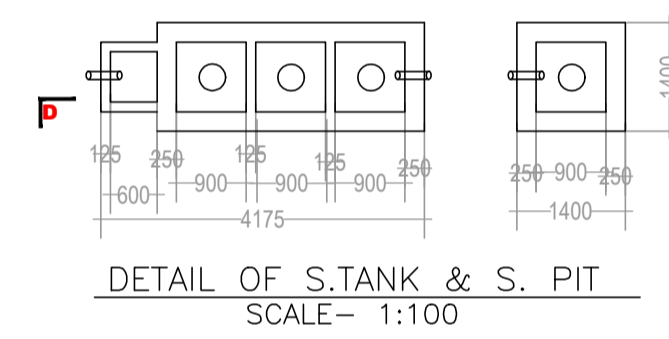
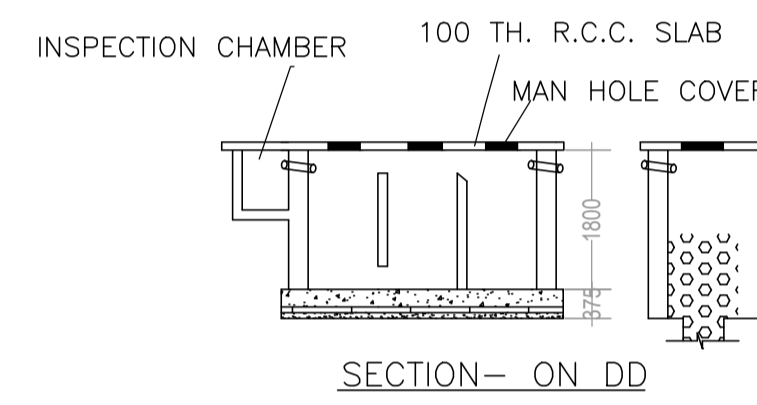
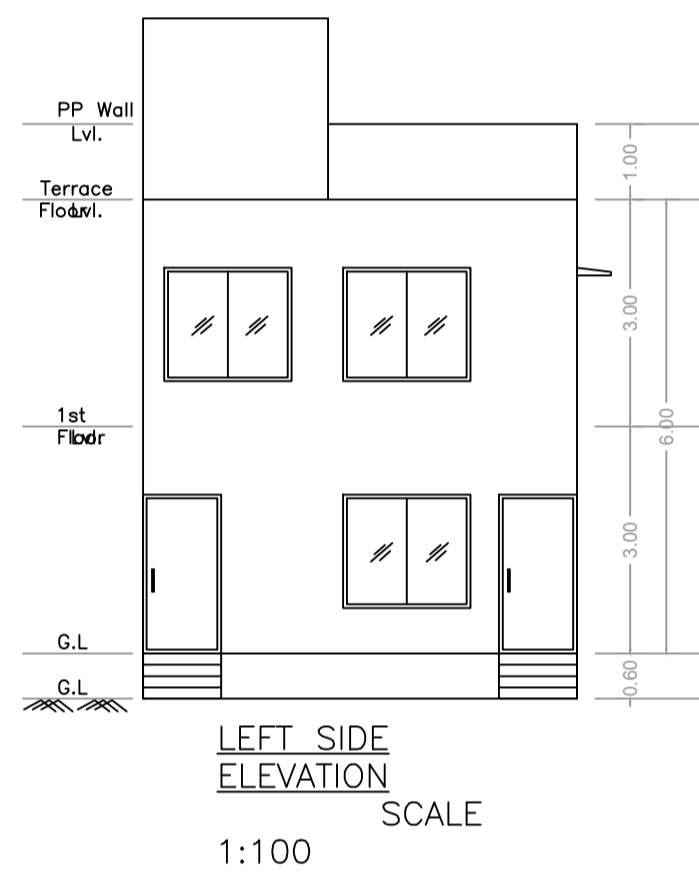

DETAIL OF RECHARGE WELL

Building :A (RESIDENTIAL)

Floor Name	Total Built Up Area (Sq.mt.)	Proposed FAR Area (Sq.mt.) Res.	Total FAR Area (Sq.mt.)	Total Consumed Additional FAR Area (Sq.mt.)	Tnmt (No.)
Ground Floor	56.25	56.25	56.25	56.25	01
First Floor	56.25	56.25	56.25	56.25	00
Terrace Floor	0.00	0.00	0.00	0.00	00
Total :	112.50	112.50	112.50	112.50	01
Total Number of Same Buildings :	1				
Total :	112.50	112.50	112.50	112.50	01

UnitBUA Table for Building :A (RESIDENTIAL)

FLOOR	Name	UnitBUA Type	UnitBUA Area	Carpet Area	No. of Rooms	No. of Tenement
GROUND FLOOR PLAN	SPLIT A	FLAT	74.68	73.95	4	1
FIRST FLOOR PLAN	SPLIT A	FLAT	0.00	0.00	4	0
Total:	-	-	74.68	73.95	8	1

