

Proposal Basic Information	
Proposal File No.	DNP/3P/003/W02/2023
Owner Name	ALOK KUMAR SOREN
Khata No	114/k
Plot No	1327/B
Village Name	Rasikpur
Use	Mixed
SubUse	Resi+Comm

Required Parking (Table 7a)

Building Name	Type	SubUse	Area (Sq.mt.)	Units		Car		TwoWheeler	
				Reqd.	Prop.	Reqd./Unit	Prop.	Reqd./Unit	Prop.
A (ALOK KUMAR SOREN)	Commercial	Restaurant	>0	20	-	1	1	-	-
		Hotel	>0	200	320.79	1	2	-	-
			>0	200	320.79	-	-	-	-
	Mixed	Resi+Comm	>0	200	151.96	1	1	-	-
			>0	200	151.96	-	-	-	-
			>0	200	151.96	-	-	-	-
Total :			-	-	-	5	5	8	18

Parking Check (Table 7b)

Vehicle Type	Reqd.		Prop.	
	No.	Area	No.	Area
Car	-	-	5	62.50
Total Car	5	62.50	5	62.50
TwoWheeler	-	-	18	36.00
Total TwoWheeler	8	16.00	18	36.00
Other Parking	-	-	-	138.04
Total		78.50		272.54

Building USE/SUBUSE Details

Building Name	Building Use	Building SubUse	Building Structure
A (ALOK KUMAR SOREN)	Residential	ResiComm Bldg	Non-Highrise

FAR & Tenement Details (Table 4c-1)

Building	No. of Same Bldg	Total Built Up Area (Sq.mt.)	Existing Built Up Area (Sq.mt.)	Proposed Built Up Area (Sq.mt.)	Deductions (Area in Sq.mt.)			Existing FAR Area (Sq.mt.)	Proposed FAR Area (Sq.mt.)	Add Area In FAR (Sq.mt.)	Total FAR Area (Sq.mt.)	Total Consumed Additional FAR Area (Sq.mt.)	Tnmt (No.)
					Lift	Accessory Use	Parking						
A (ALOK KUMAR SOREN)	1	1287.83	361.56	926.27	20.70	79.43	131.07	339.13	525.18	13.11	1039.12	1039.12	01
Grand Total	1	1287.83	361.56	926.27	20.70	79.43	131.07	339.13	525.18	13.11	1039.12	1039.12	01

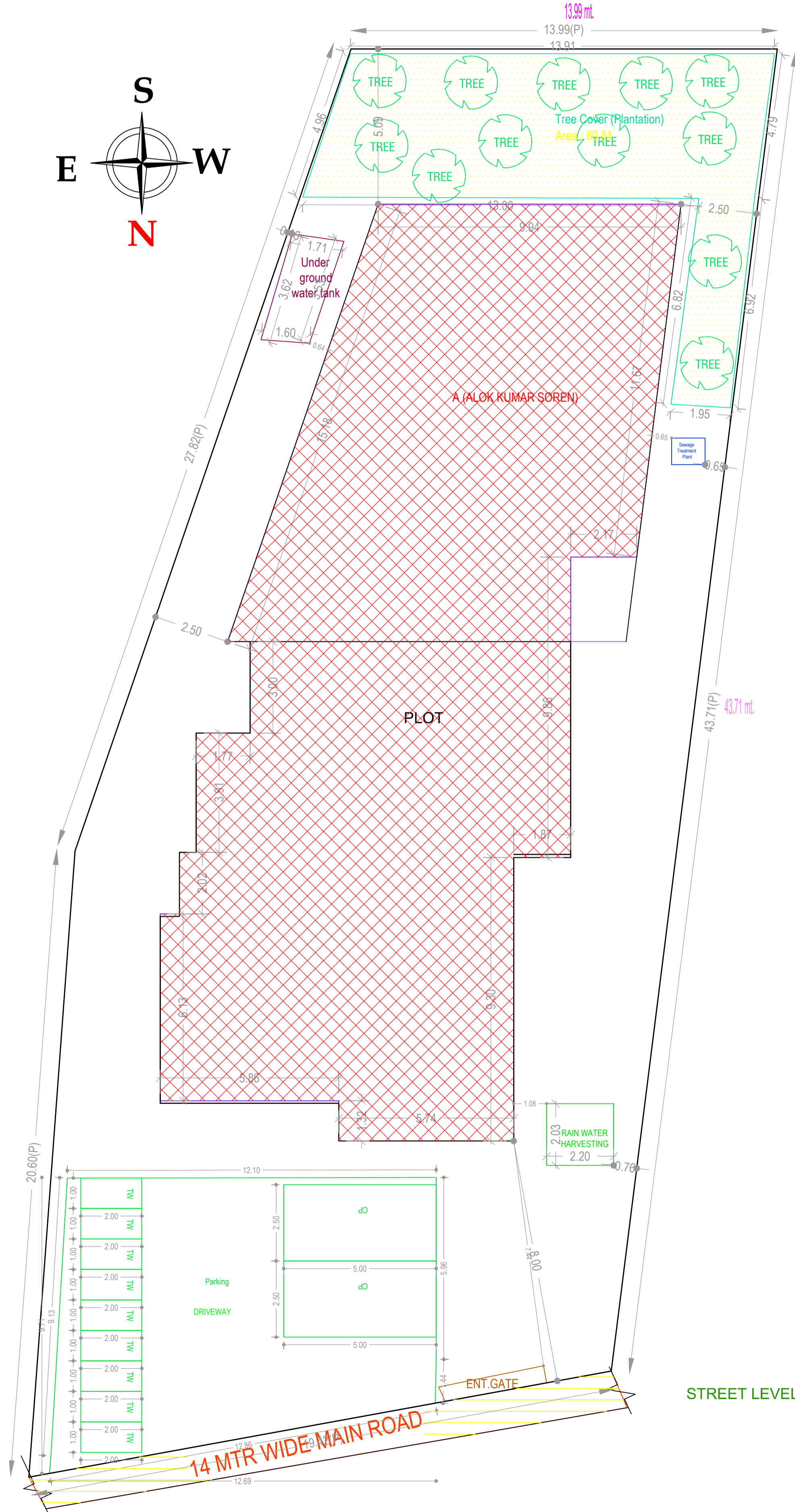

AREA STATEMENT DUMKA NAGAR PARISHAD		VERSION NO. : 1.0.66
PROJECT DETAIL:		VERSION DATE: 16/10/2020
Region: JHARKHAND URBAN LOCAL BODIES	Plot Use: Mixed	
District: DUMKA	Plot SubUse: Resi+Comm	
Authority: DUMKA NAGAR PARISHAD	PlotNearbyReligiousStructure: NA	
Inward No: DNP/3P/003/W02/2023	Plot/SubPlot No: 1327/B	
Application Type: General Proposal	North: Road Width - 14	
Project Type: Building Permission	South: Plot No. - SANDHYA RANI	
Nature of Development: Addition or Alteration	East: Plot No. - TANK OF AGRICULTURAL LAND	
Location of Development Area: Old Area	West: Plot No. - AMIT KUMAR DEY	
AREA DETAILS:		SQ.MT.
AREA OF PLOT (Minimum)	(A)	805.68
NET AREA OF PLOT(Gross Plot Area - Deduction from Gross Plot area)	(A-Deductions)	805.68
Deduction for Balance Plot Area(from Gross Plot Area)		
Common Plot		80.84
Total		80.84
BALANCE AREA OF PLOT(Net Plot Area - Recreational/Amenity space)	(A-Deductions)	724.84
PLOT AREA FOR COVERAGE(Net Plot Area)	(A-Deductions)	805.68
Plot Area for FAR (Net Plot Area + RoadWidening Area)	(A-Deductions)	805.68
COVERAGE CHECK		
Permissible Coverage area (60.00 %)		483.41
Proposed Coverage Area (42.25 %)		340.39
Total Prop. Coverage Area (42.25 %)		340.39
Balance coverage area (17.75 %)		143.02
FAR CHECK		
Perm. FAR Area (2.50)		2014.20
Total Perm. FAR area		2014.20
Residential FAR		339.13
Commercial FAR		686.87
Proposed FAR Area		1039.11
Total Proposed FAR Area		1039.11
Consumed FAR (Factor)		1.29
Balance FAR Area		975.09
BUILT UP AREA CHECK		
Total Proposed BuiltUp Area		1287.83
ARCHITECT (Regd)		SURJYA CHOUDHURY
ENGINEER (Regd)		
SUPERVISOR (Regd)		
OWNER (Regd)		ALOK KUMAR SOREN
DEVELOPMENT AUTHORITY		LOCAL BODY

Buildingwise Floor FAR Details

Floor Name	Building Name A (ALOK KUMAR SOREN)				Total			
	Proposed Built Up Area (Sq.mt.)	Existing Built Up Area (Sq.mt.)	Proposed FAR Area (Sq.mt.)	Existing FAR Area (Sq.mt.)	Total Proposed Built Up Area (Sq.mt.)	Total Existing Built Up Area (Sq.mt.)	Total FAR Area (Sq.mt.)	Total Existing FAR Area (Sq.mt.)
Basement Floor	165.14	0.00	13.11	0.00	165.14	0.00	13.11	0.00
Ground Floor	159.61	180.78	159.61	165.65	159.61	180.78	159.61	165.65
First Floor	165.14	180.78	161.69	173.48	165.14	180.78	161.69	173.48
Second Floor	145.46	0.00	121.86	0.00	145.46	0.00	121.86	0.00
Third Floor	145.46	0.00	121.86	0.00	145.46	0.00	121.86	0.00
Fourth Floor	145.46	0.00	121.86	0.00	145.46	0.00	121.86	0.00
Terrace Floor	0.00	0.00	0.00	0.00	0.00	0.00	0.00	0.00
Total :	926.27	361.56	699.99	339.13	926.27	361.56	699.99	339.13

COLOR INDEX	
PLOT BOUNDARY	Black
ABUTTING ROAD	Green
PROPOSED CONSTRUCTION	Red
COMMON PLOT	Yellow
ROAD WIDENING AREA	Blue
EXISTING (To be retained)	Blue
EXISTING (To be demolished)	Yellow

LTP NAME AND SIGNATURE	STRUCTURAL ENG'S NAME AND SIGNATURE	BUILDER NAME AND SIGNATURE	DIGITAL SIGNATURE
SURJYA CHOUDHURY DNP/ENG/0002/2018			

Proposal Basic Information	
Proposal File No.	DNP/EN/003/W02/2023
Owner Name	ALOK KUMAR SOREN
Khata No	114/k
Plot No	1327/B
Village Name	Rasikpur
Use	Mixed
SubUse	Resi+Comm

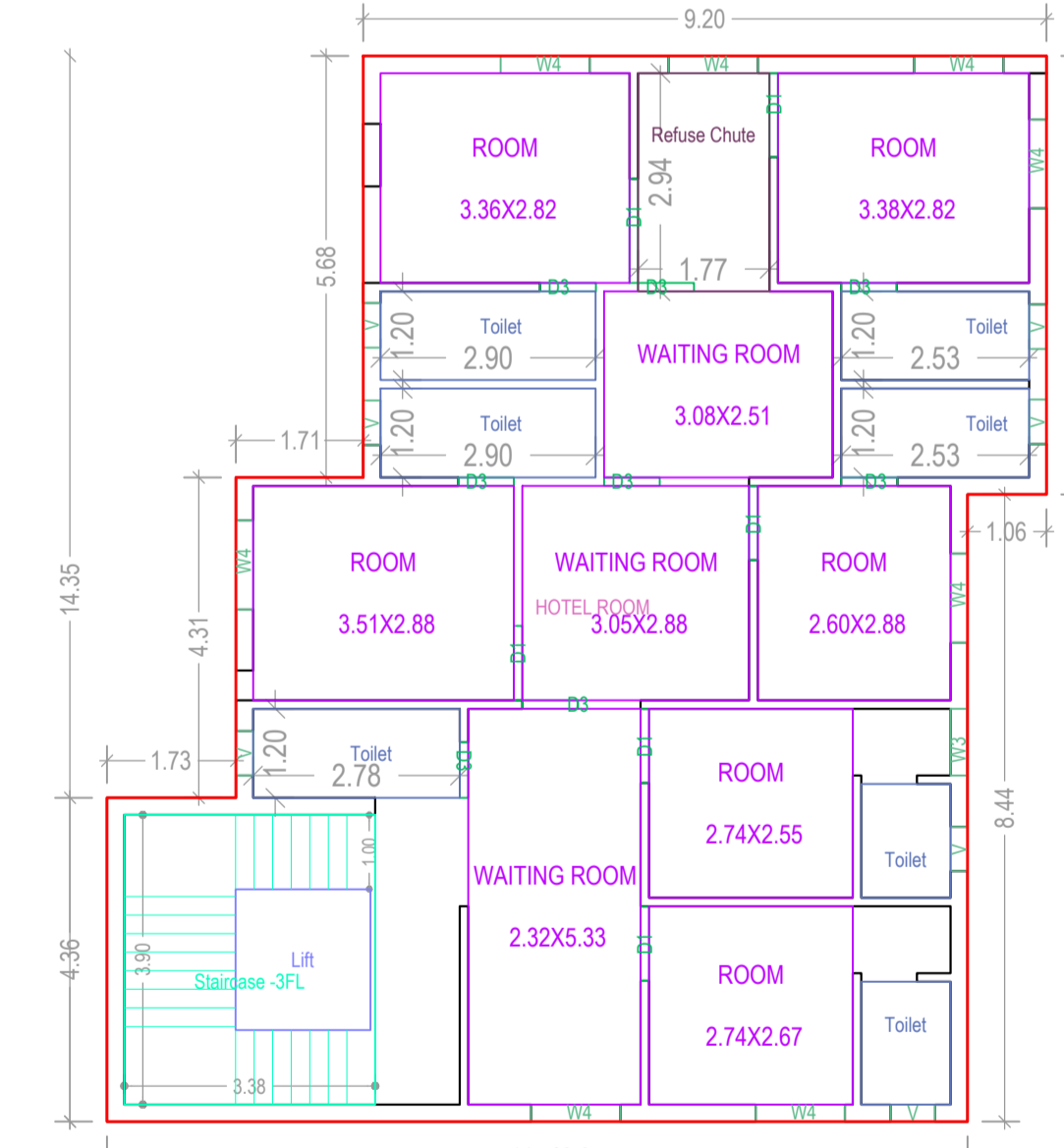
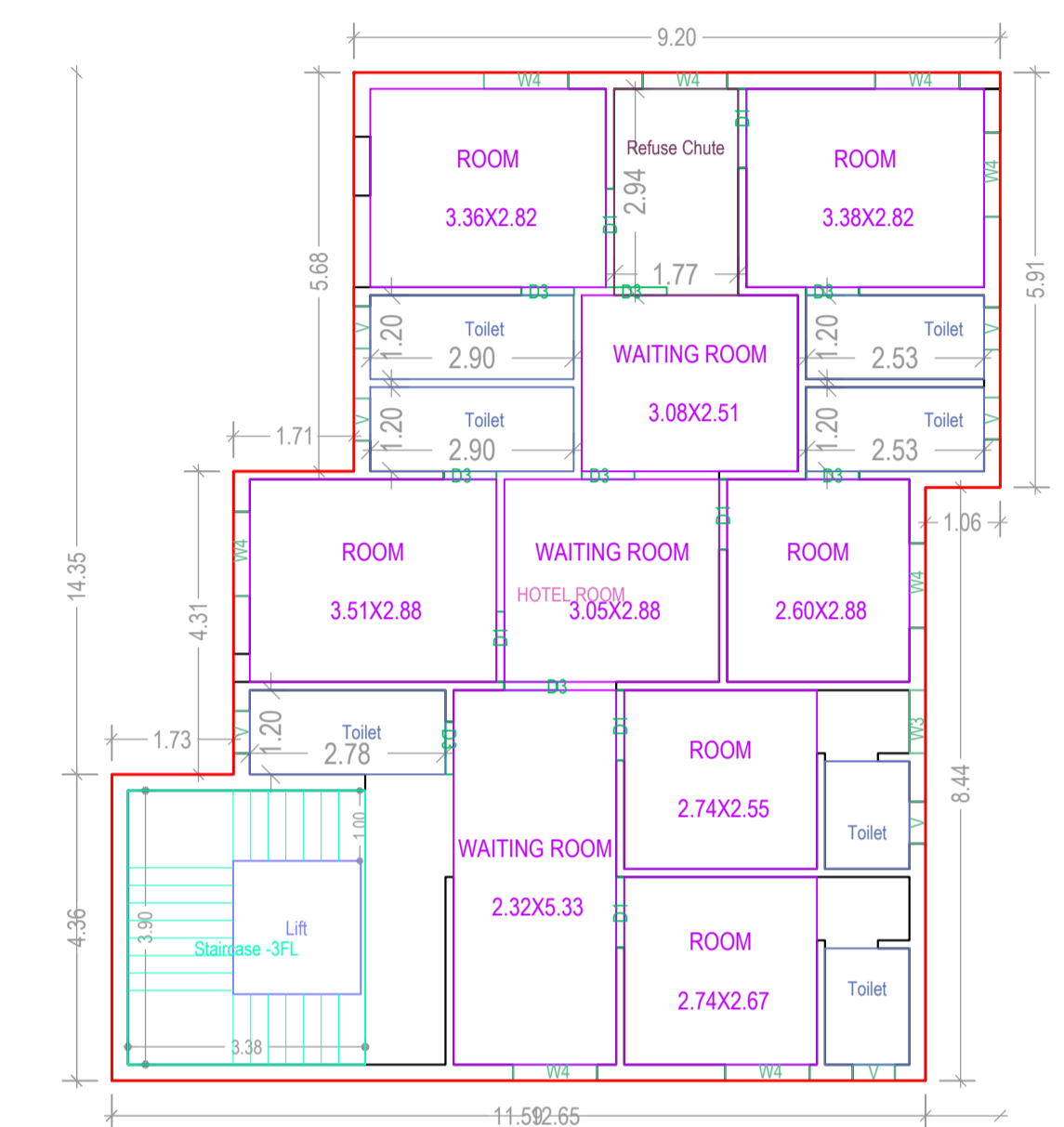
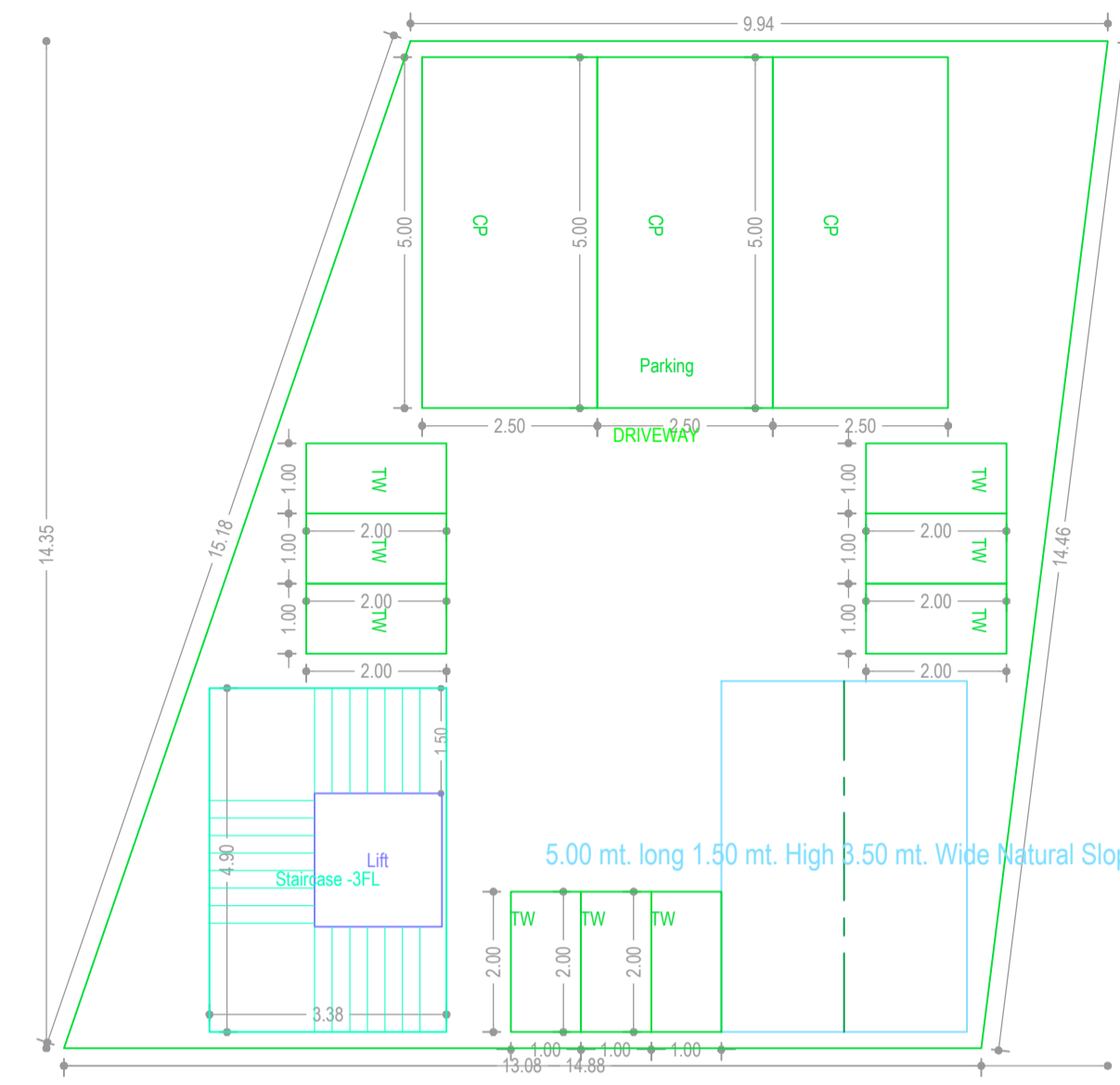
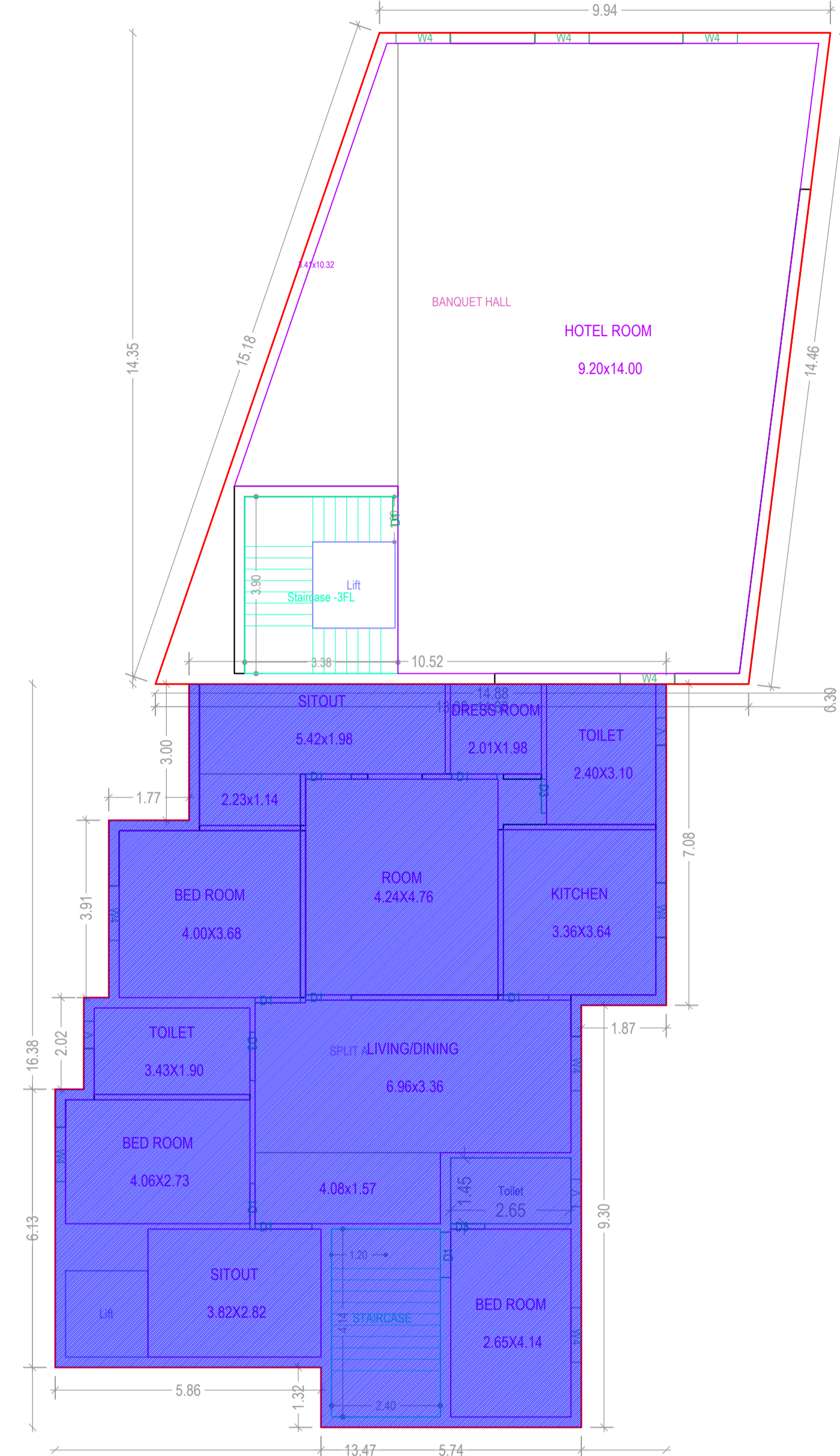
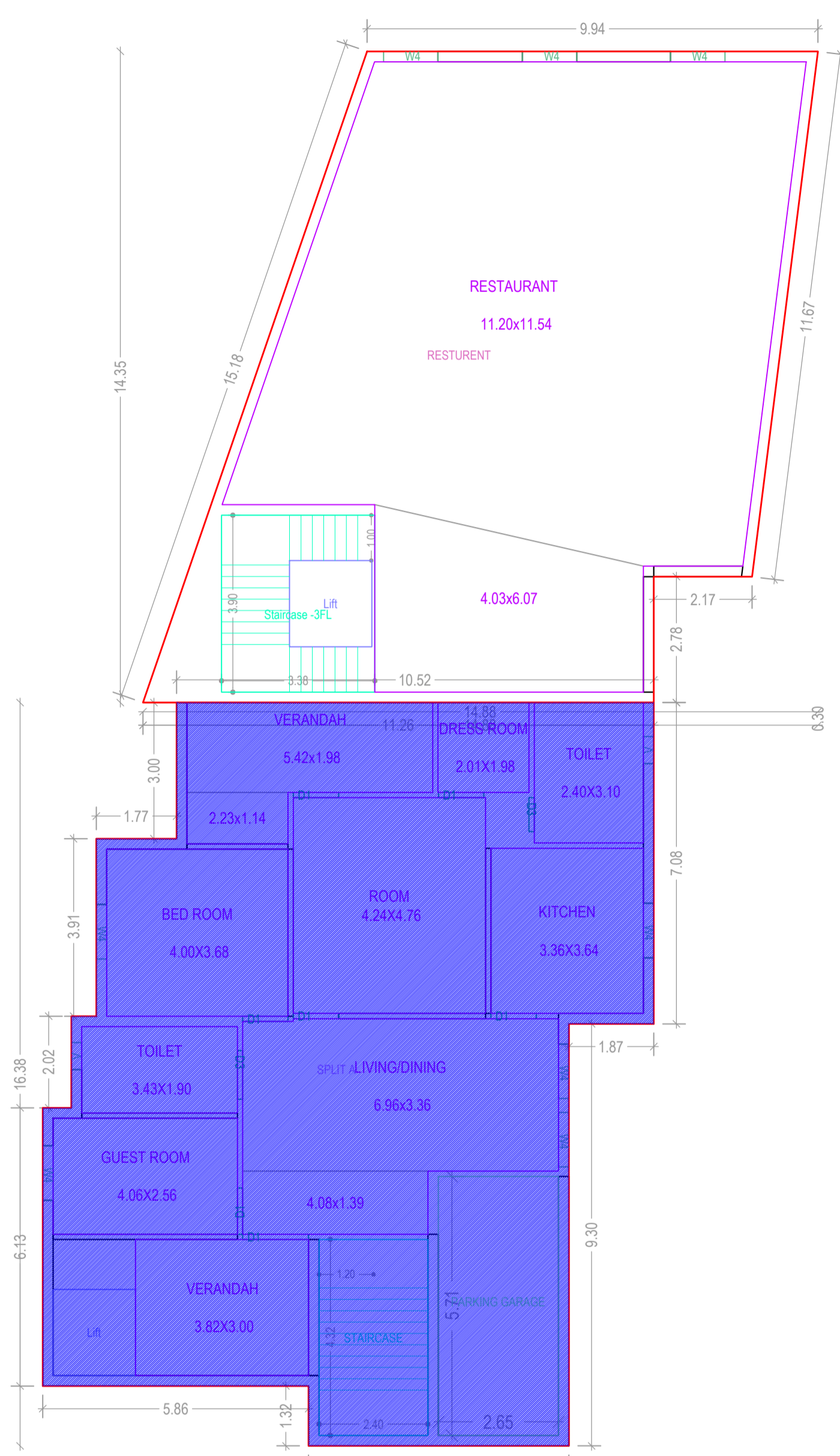

LTP NAME AND SIGNATURE	STRUCTURAL ENG'S NAME AND SIGNATURE	BUILDER NAME AND SIGNATURE	DIGITAL SIGNATURE
SURJYA CHOUDHURY DNP/ENG/002/2018			

Proposal Basic Information	
Proposal File No.	DNP/3F/003/W02/2023
Owner Name	ALOK KUMAR SOREN
Khata No	114/k
Plot No	1327/B
Village Name	Rasikpur
Use	Mixed
SubUse	Resi+Comm

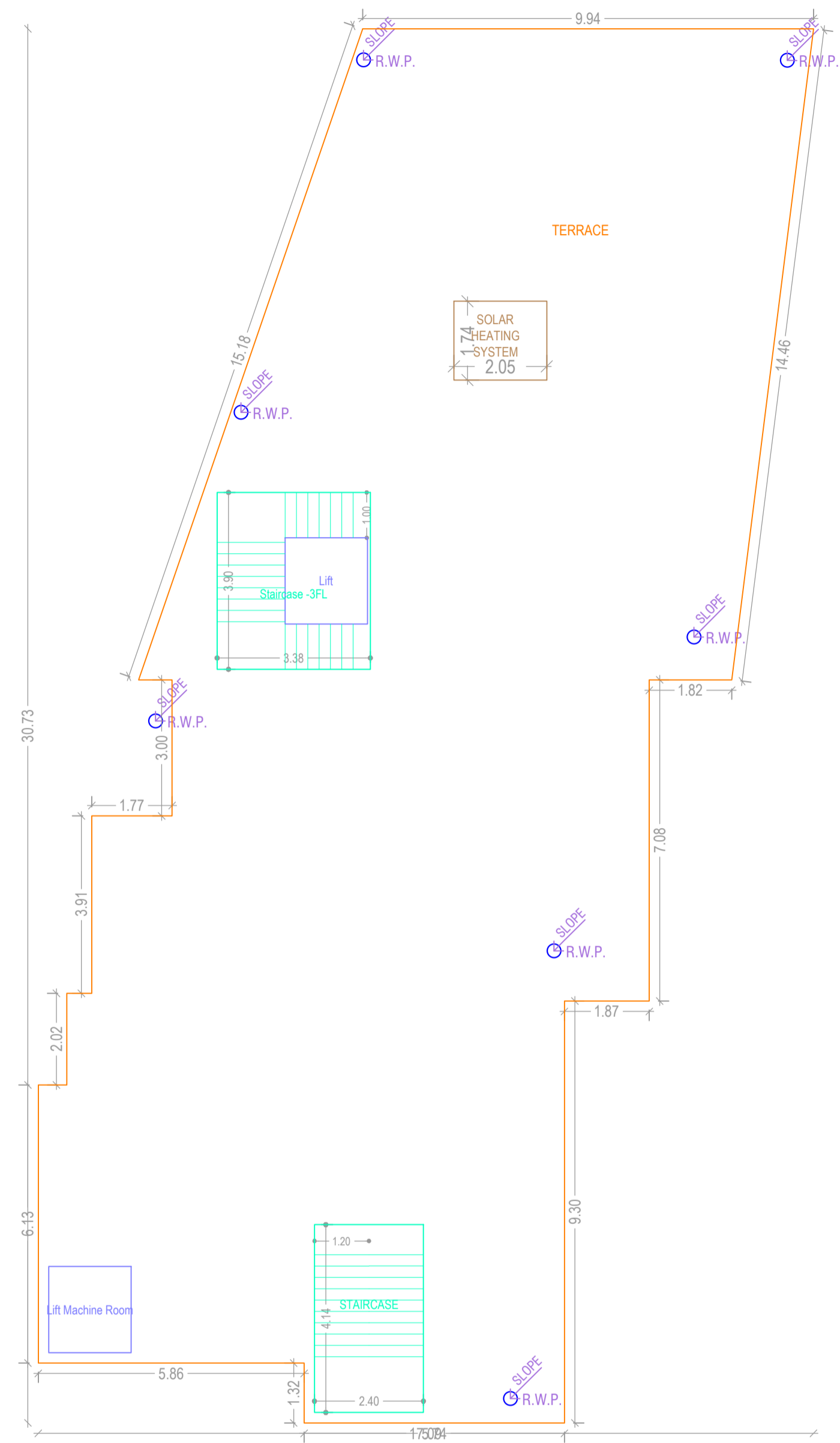

TERRACE FLOOR PLAN
(SCALE 1:100)

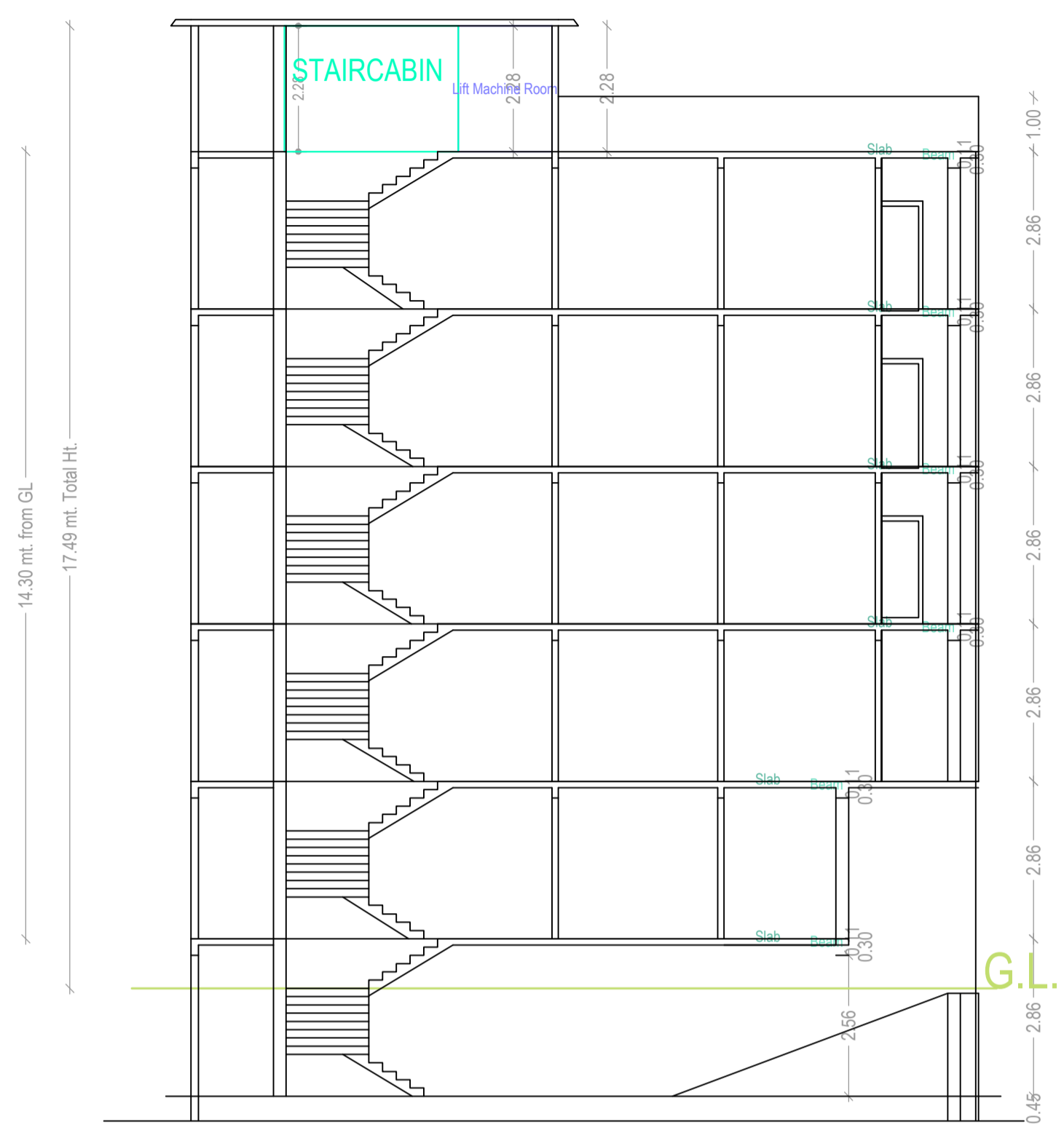

SECTION AT X-X

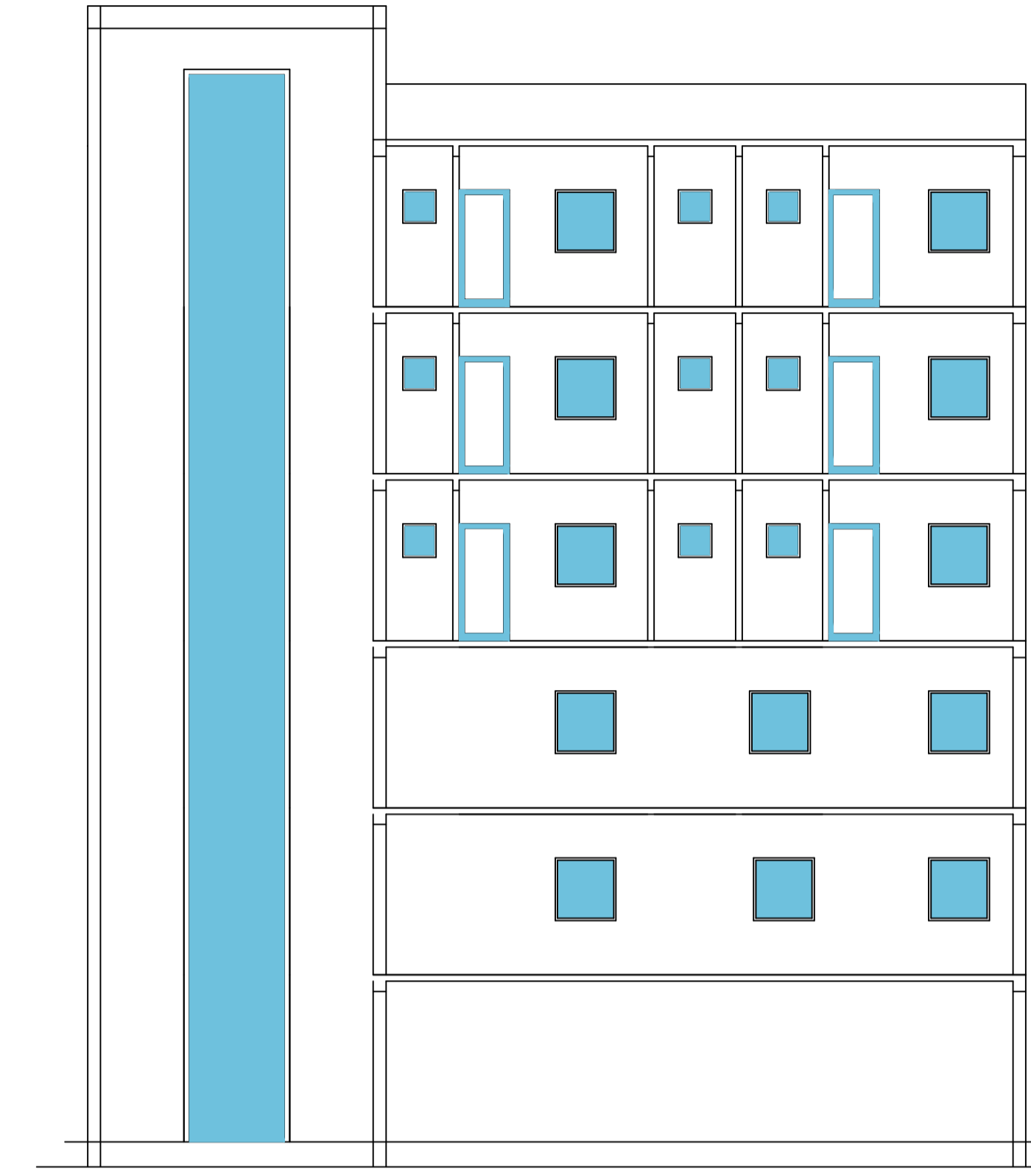

SECTION AT Y-Y

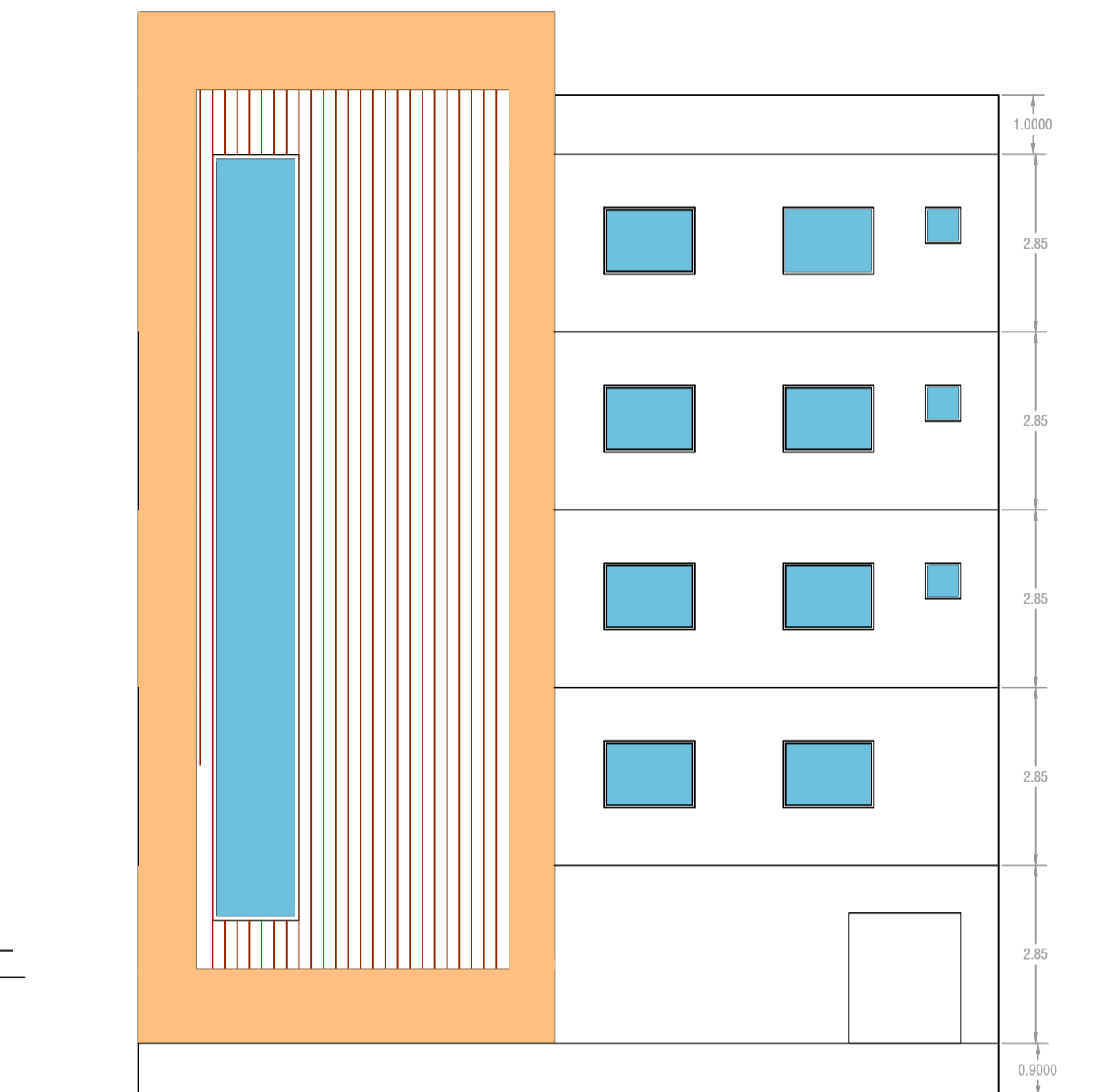

FRONT ELEVATION

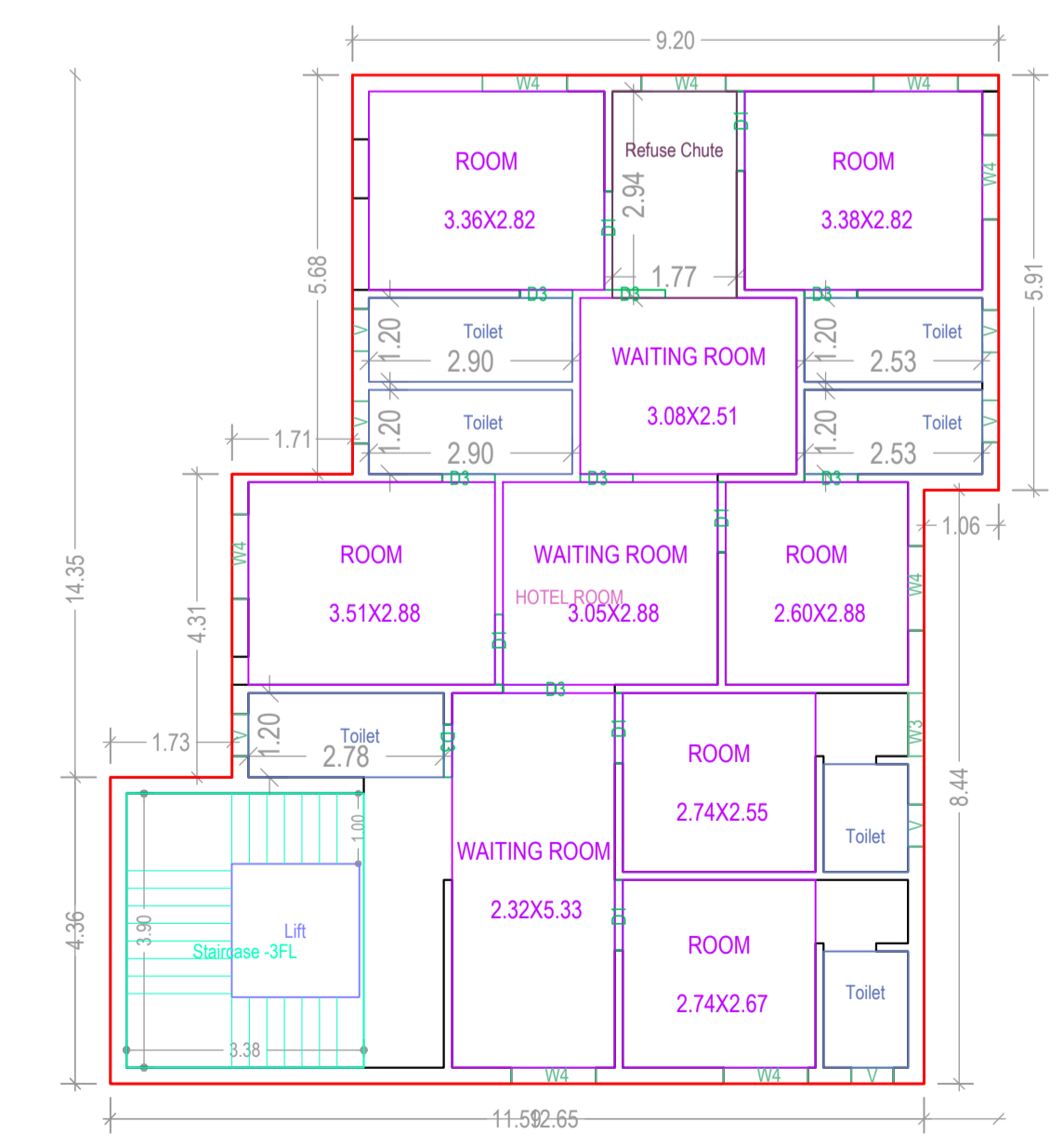

SECOND FLOOR PLAN
(Proposed)
(SCALE 1:100)

Building :A (ALOK KUMAR SOREN)

Floor Name	Total Built Up Area (Sq.mt.)	Existing Built Up Area (Sq.mt.)	Proposed Built Up Area (Sq.mt.)	Deductions (Area in Sq.mt.)			Existing FAR Area (Sq.mt.)	Proposed FAR Area (Sq.mt.)	Add Area In FAR (Sq.mt.)	Total FAR Area (Sq.mt.)	Total Consumed Additional FAR Area (Sq.mt.)	Trmt (No.)
				Lift	Accessory Use	Parking						
Basement Floor	165.14	0.00	165.14	3.45	0.00	131.07	0.00	0.00	13.11	13.11	13.11	00
Ground Floor	340.39	180.78	159.61	0.00	15.13	0.00	165.65	159.61	0.00	325.26	325.26	01
First Floor	345.92	180.78	165.14	6.90	3.85	0.00	173.48	0.00	0.00	335.17	335.17	00
Second Floor	145.46	0.00	145.46	3.45	20.15	0.00	0.00	121.86	0.00	121.86	121.86	00
Third Floor	145.46	0.00	145.46	3.45	20.15	0.00	0.00	121.86	0.00	121.86	121.86	00
Fourth Floor	145.46	0.00	145.46	3.45	20.15	0.00	0.00	121.86	0.00	121.86	121.86	00
Terrace Floor	0.00	0.00	0.00	0.00	0.00	0.00	0.00	0.00	0.00	0.00	0.00	00
Total	1287.83	361.56	926.27	20.70	79.43	131.07	339.13	525.18	13.11	1039.12	1039.12	01
Total Number of Same Buildings	1											
Total	1287.83	361.56	926.27	20.70	79.43	131.07	339.13	525.18	13.11	1039.12	1039.12	01

SCHEDULE OF DOOR:

BUILDING NAME	NAME	LENGTH	HEIGHT	NOS
A (ALOK KUMAR SOREN)	D1	0.50	2.10	01
A (ALOK KUMAR SOREN)	D3	0.75	2.10	24
A (ALOK KUMAR SOREN)	D3	0.76	2.10	03
A (ALOK KUMAR SOREN)	D1	1.00	2.10	24
A (ALOK KUMAR SOREN)	D1	1.02	2.10	01
A (ALOK KUMAR SOREN)	D3	1.07	2.10	02
A (ALOK KUMAR SOREN)	D1	1.13	2.10	03
A (ALOK KUMAR SOREN)	D1	1.25	2.10	01
A (ALOK KUMAR SOREN)	D1	1.40	2.10	03
A (ALOK KUMAR SOREN)	D1	1.45	2.10	01

SCHEDULE OF WINDOW/VENTILATION:

BUILDING NAME	NAME	LENGTH	HEIGHT	NOS
A (ALOK KUMAR SOREN)	V	0.60	2.70	04
A (ALOK KUMAR SOREN)	W4	1.20	2.70	38

UnitBUA Table for Building :A (ALOK KUMAR SOREN)

FLOOR	Name	UnitBUA Type	Entity Type	UnitBUA Area	Carpet Area	No. of Rooms	No. of Tenement
GROUND FLOOR PLAN	SPLIT A	FLAT	Existing	335.68	316.73	10	1
FIRST FLOOR PLAN	SPLIT A	FLAT	Existing	0.00	0.00	11	0
Total:	-	-	-	1019.11	954.33	50	1

LTP NAME AND SIGNATURE	STRUCTURAL ENG'S NAME AND SIGNATURE	BUILDER NAME AND SIGNATURE	DIGITAL SIGNATURE
SURJYA CHOUDHURY DNP/ENG/002/2018			

Proposal Basic Information	
Proposal File No.	DNP/3P/2023/W02/2023
Owner Name	ALOK KUMAR SOREN
Khata No	114/k
Plot No	1327/B
Village Name	Rasikpur
Use	Mixed
SubUse	Resi+Comm

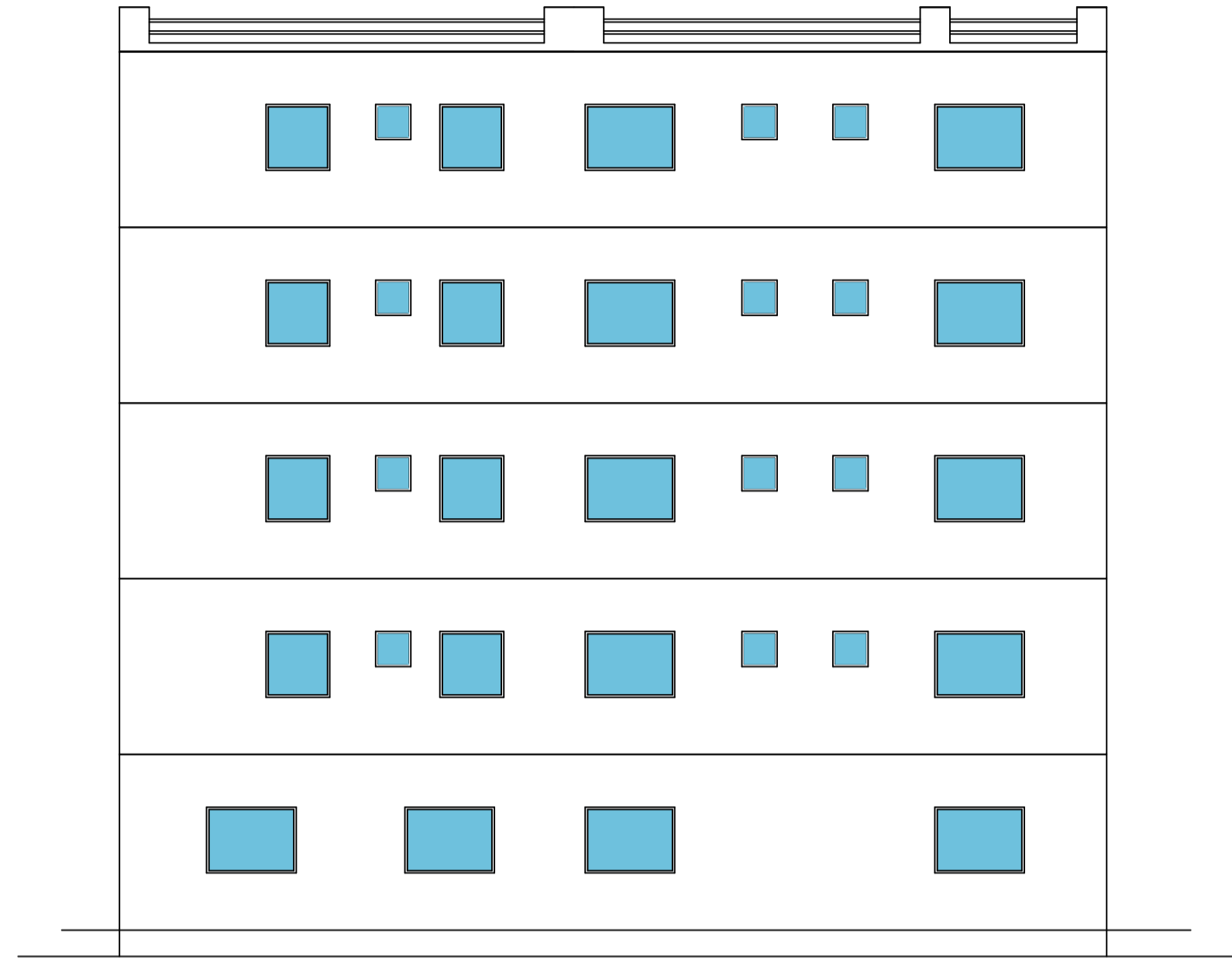

SIDE ELEVATION

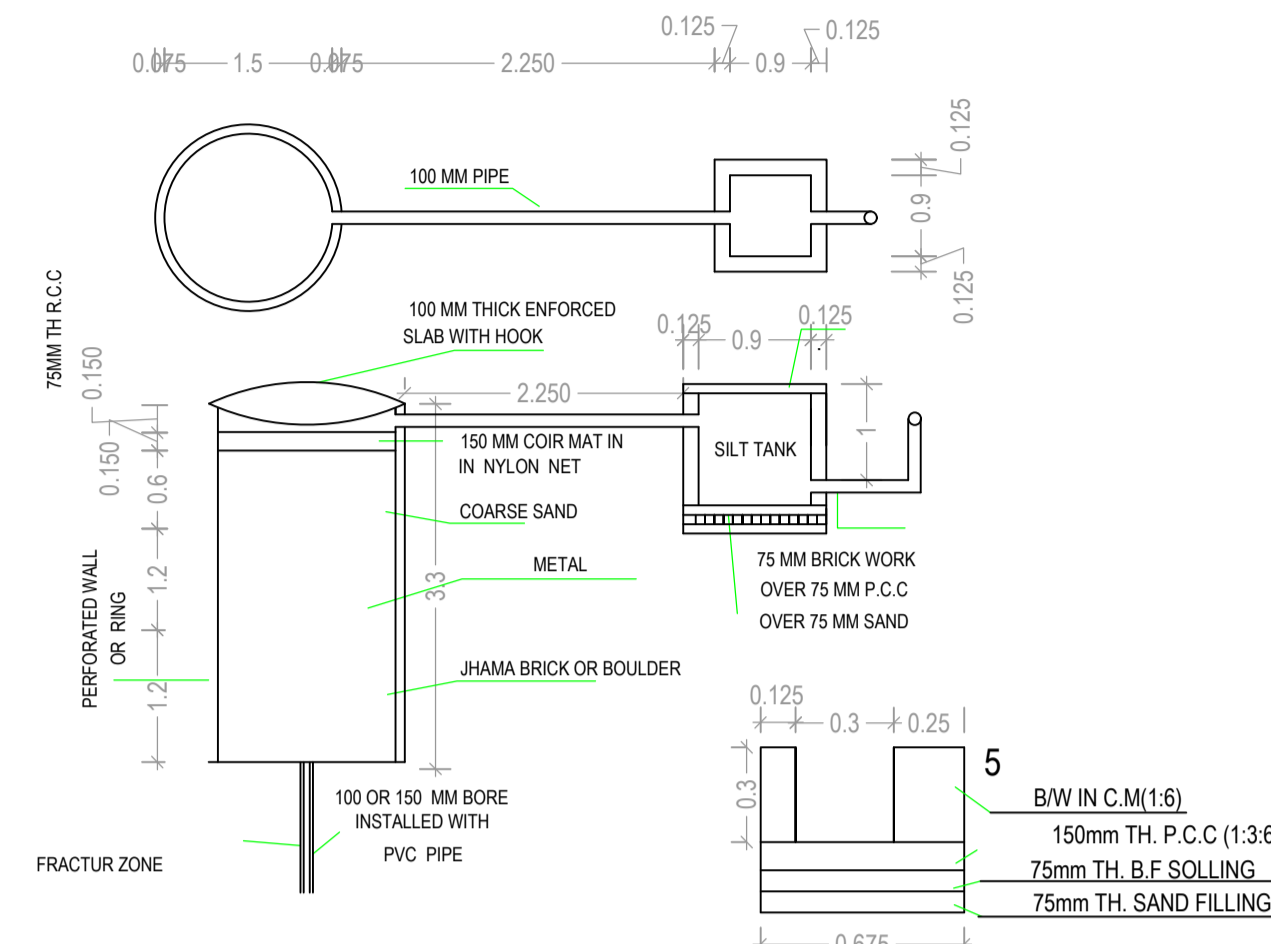

DETAIL OF RECHARGE WELL SCALE - N.T.S.
SECTION OF DRAIN SLOPE OF DRAIN=1:200

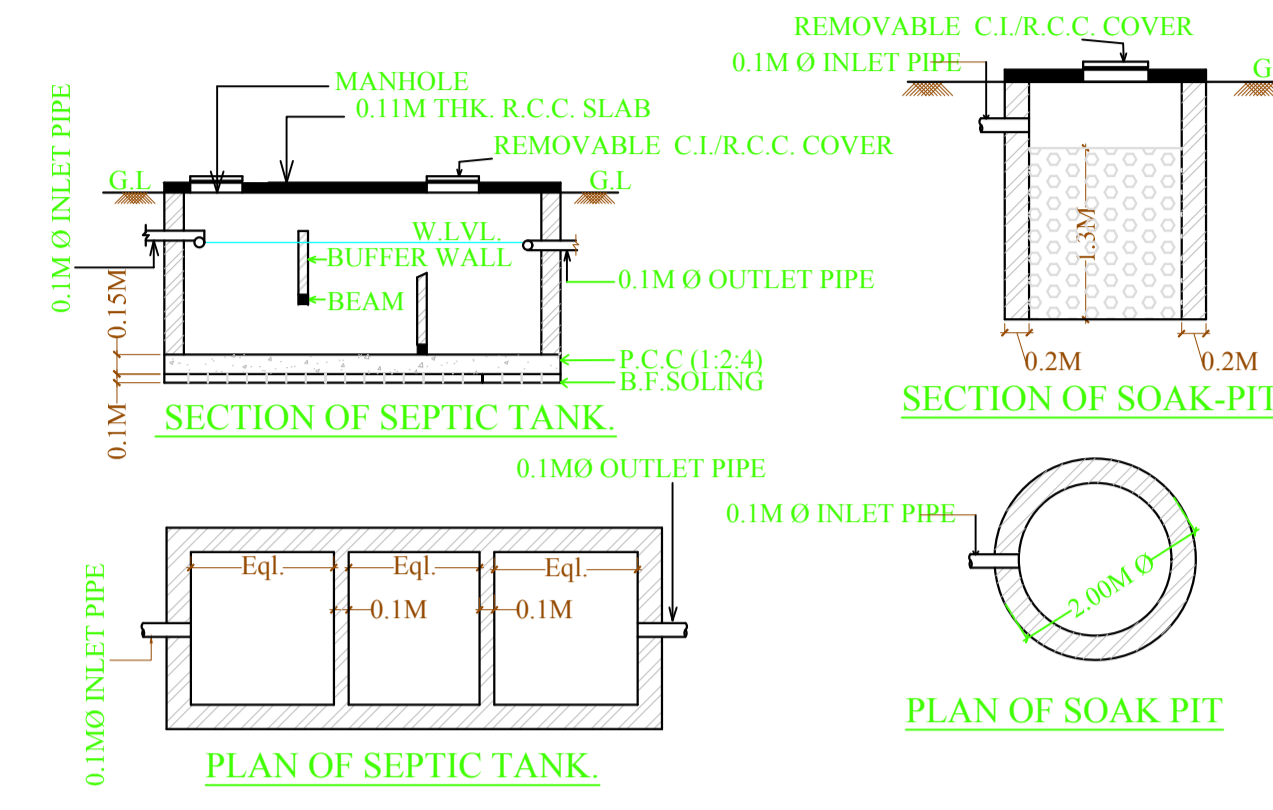

SECTION OF SEPTIC TANK
SECTION OF SOAK-PIT
PLAN OF SOAK PIT
PLAN OF SEPTIC TANK

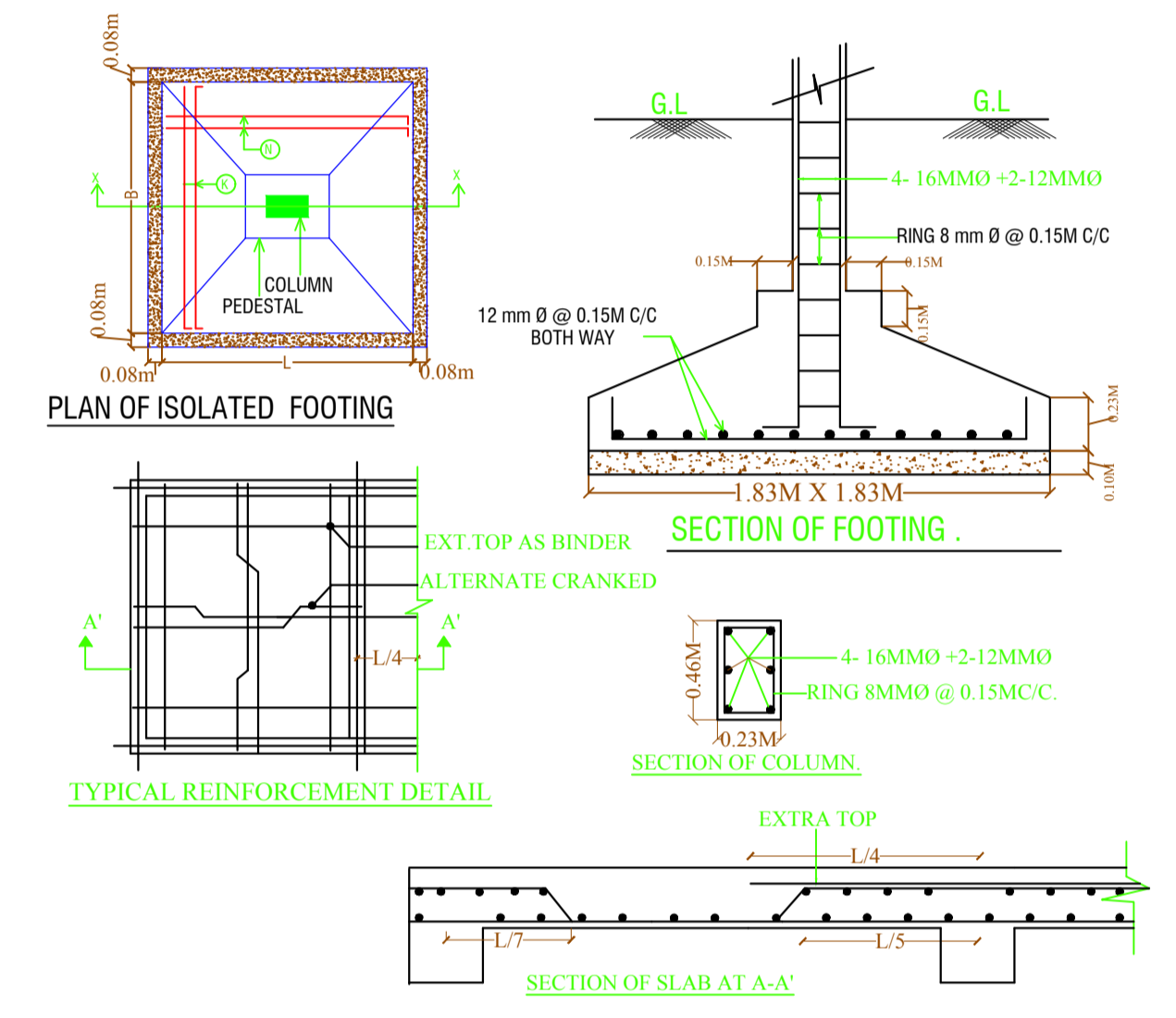

PLAN OF ISOLATED FOOTING
SECTION OF FOOTING
SECTION OF COLUMN
TYPICAL REINFORCEMENT DETAIL
SECTION OF SLAB AT A-A

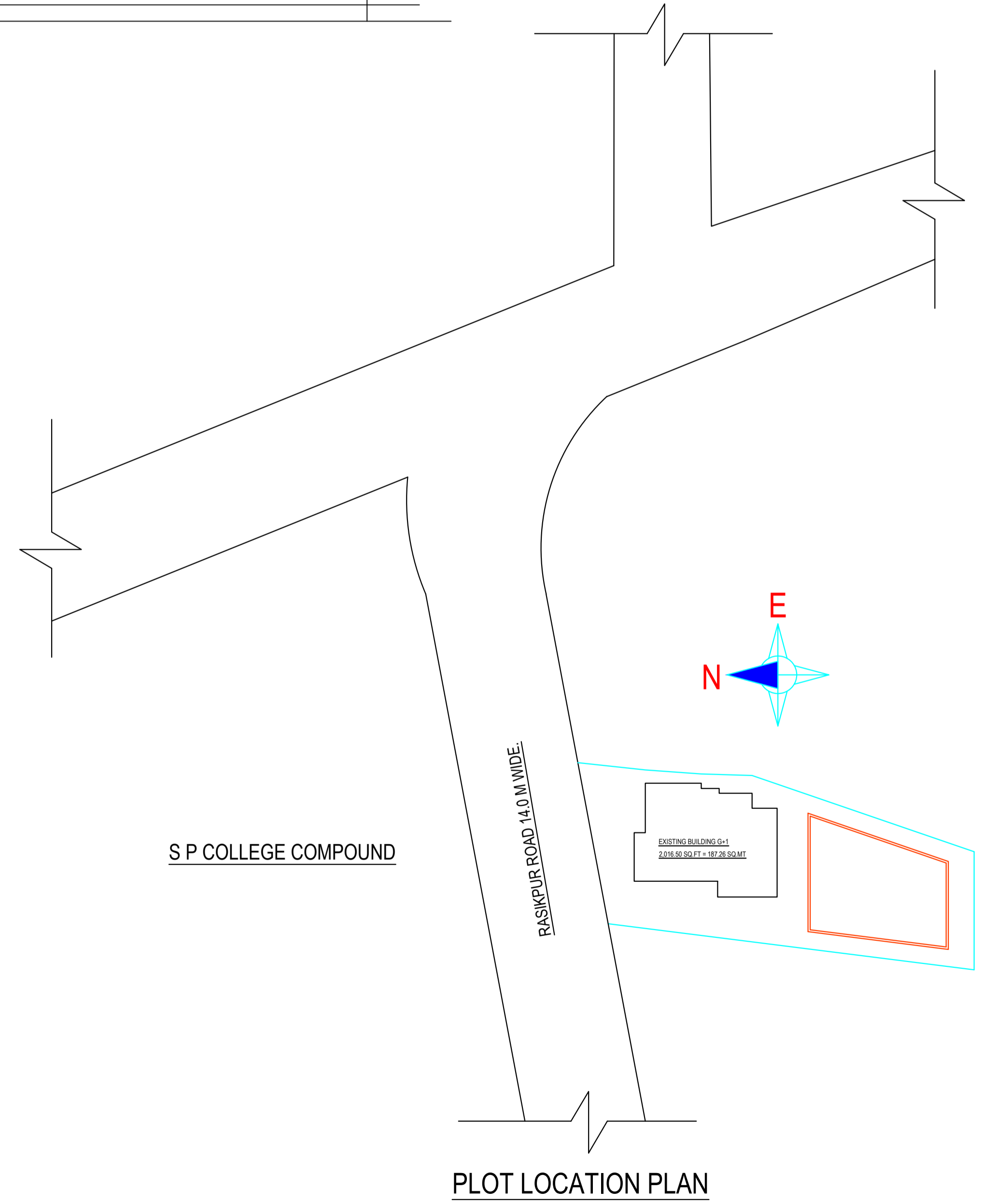

PLOT LOCATION PLAN

LTP NAME AND SIGNATURE	STRUCTURAL ENG'S NAME AND SIGNATURE	BUILDER NAME AND SIGNATURE	DIGITAL SIGNATURE
SURJYA CHOUDHURY DNP/ENG/0002/2018			