

Proposal Basic Information	
Proposal File No.	DNP/IB/0002/W16/2023
Owner Name	SMT INDU SINGH
Khata No	25/4/1
Plot No	732 P
Village Name	Dumka Town
Use	Residential
SubUse	Bungalow/ Dwelling / Non Apartment

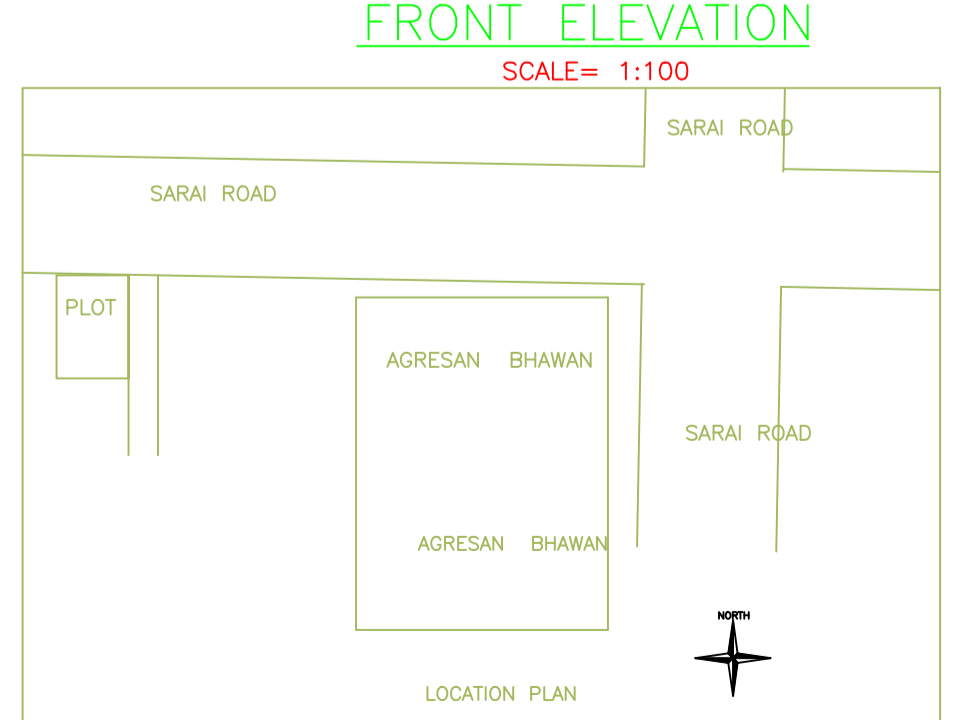
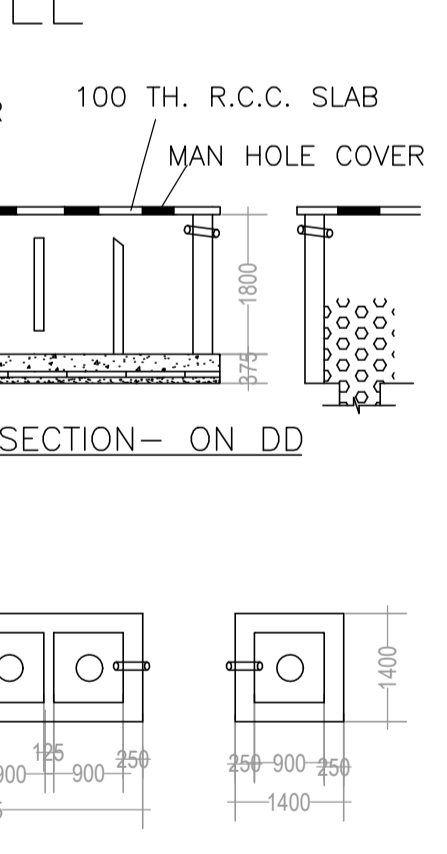
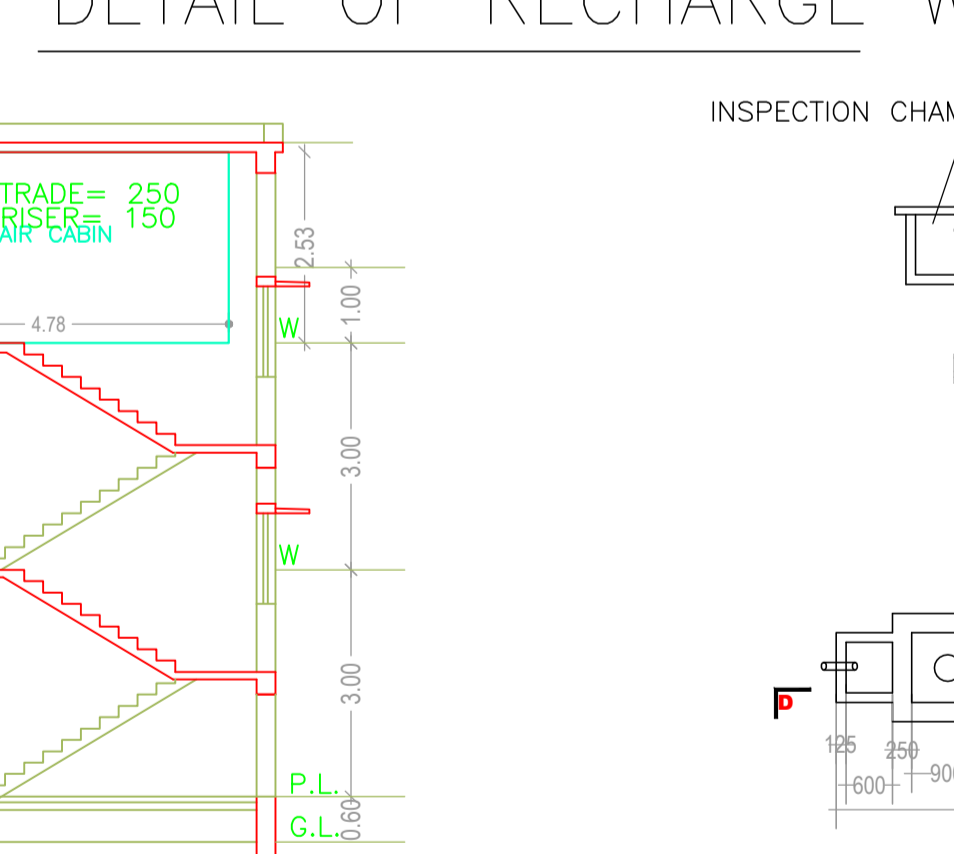
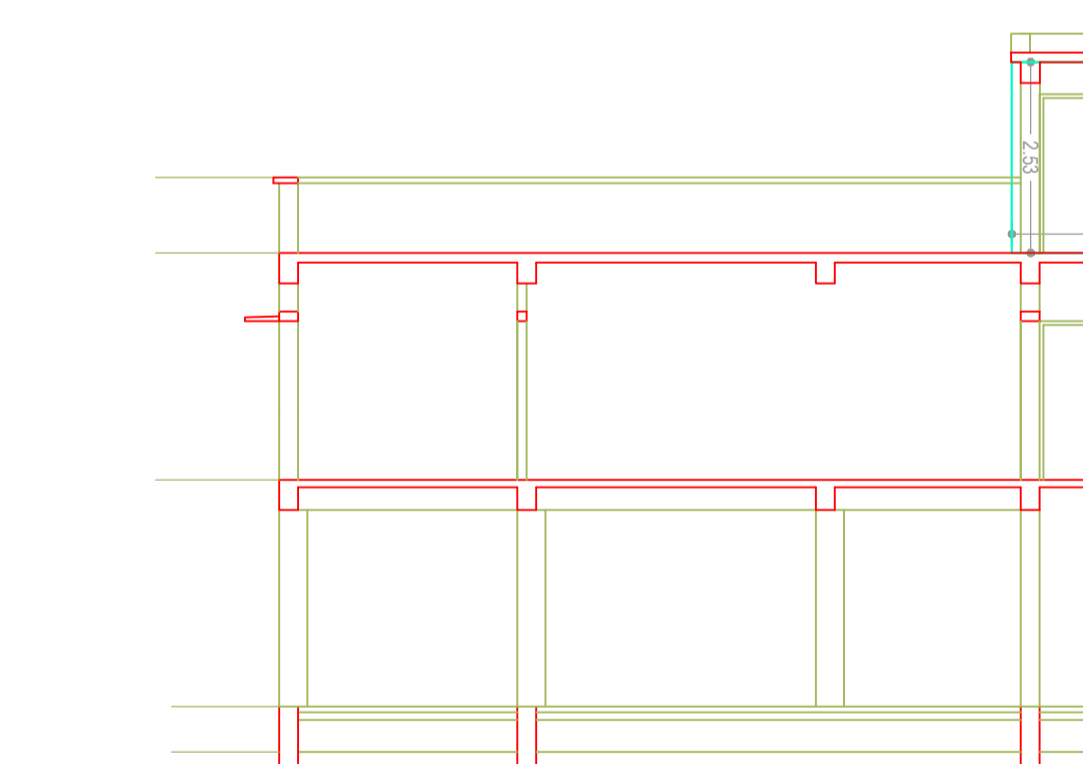
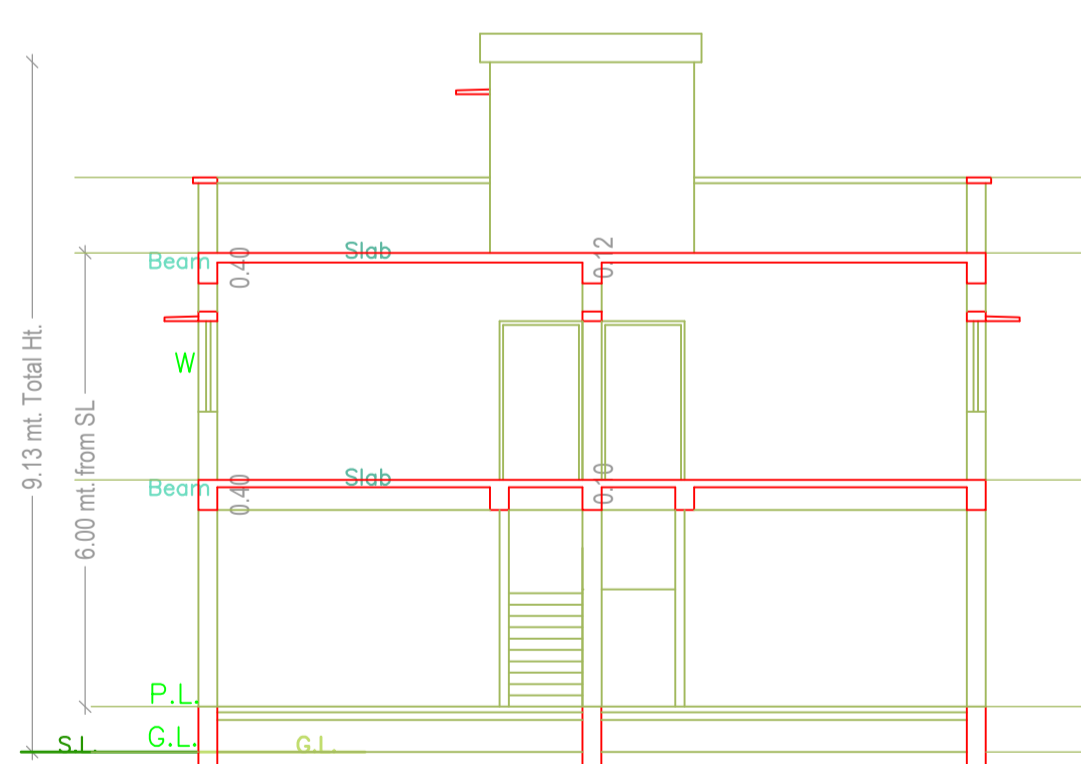
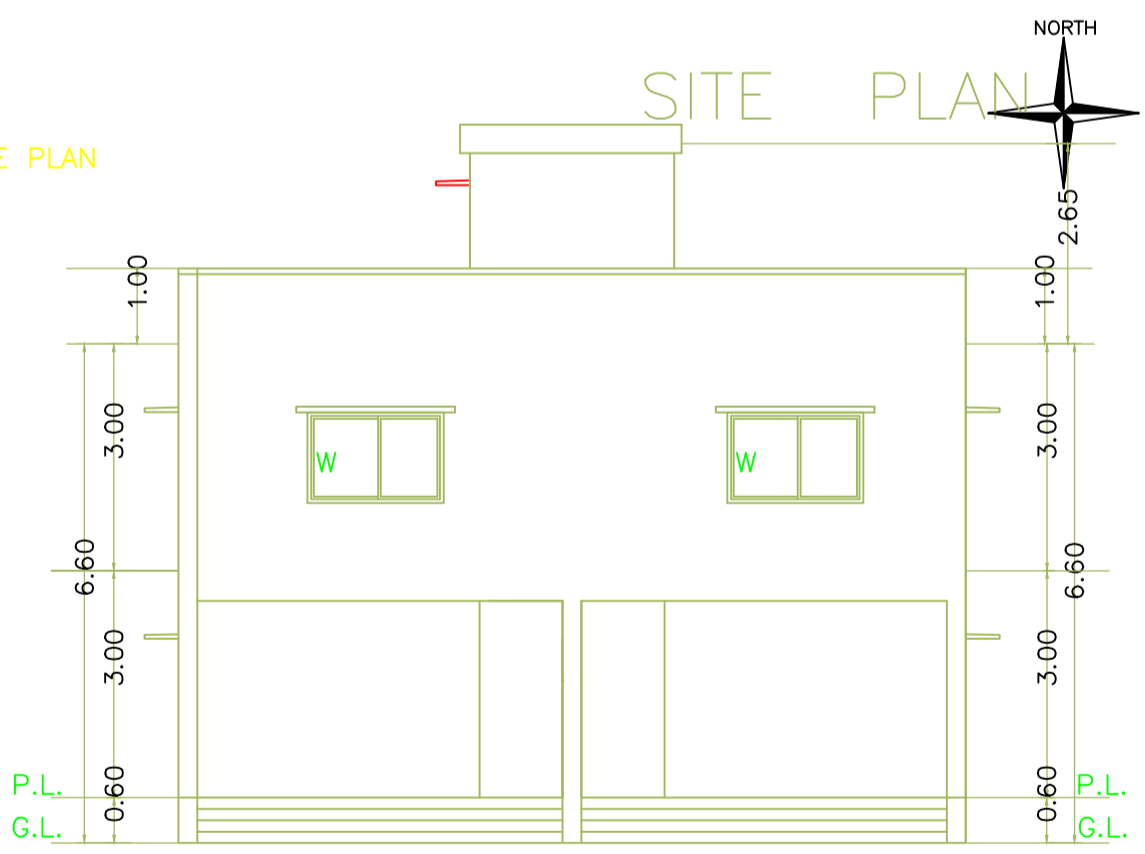
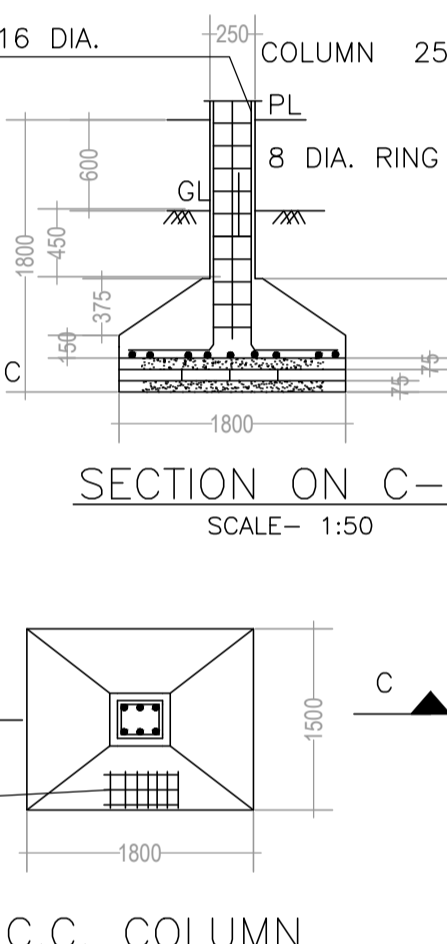
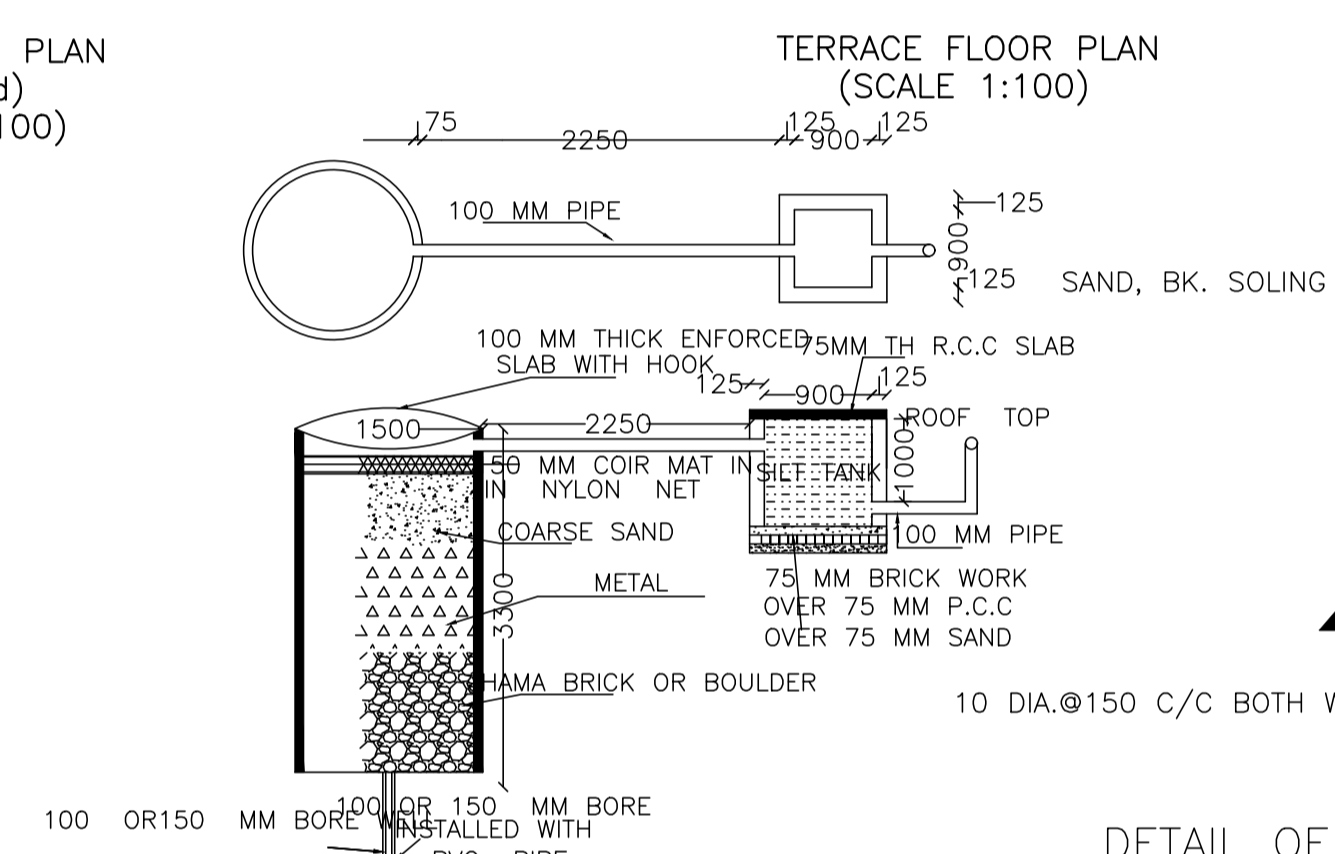
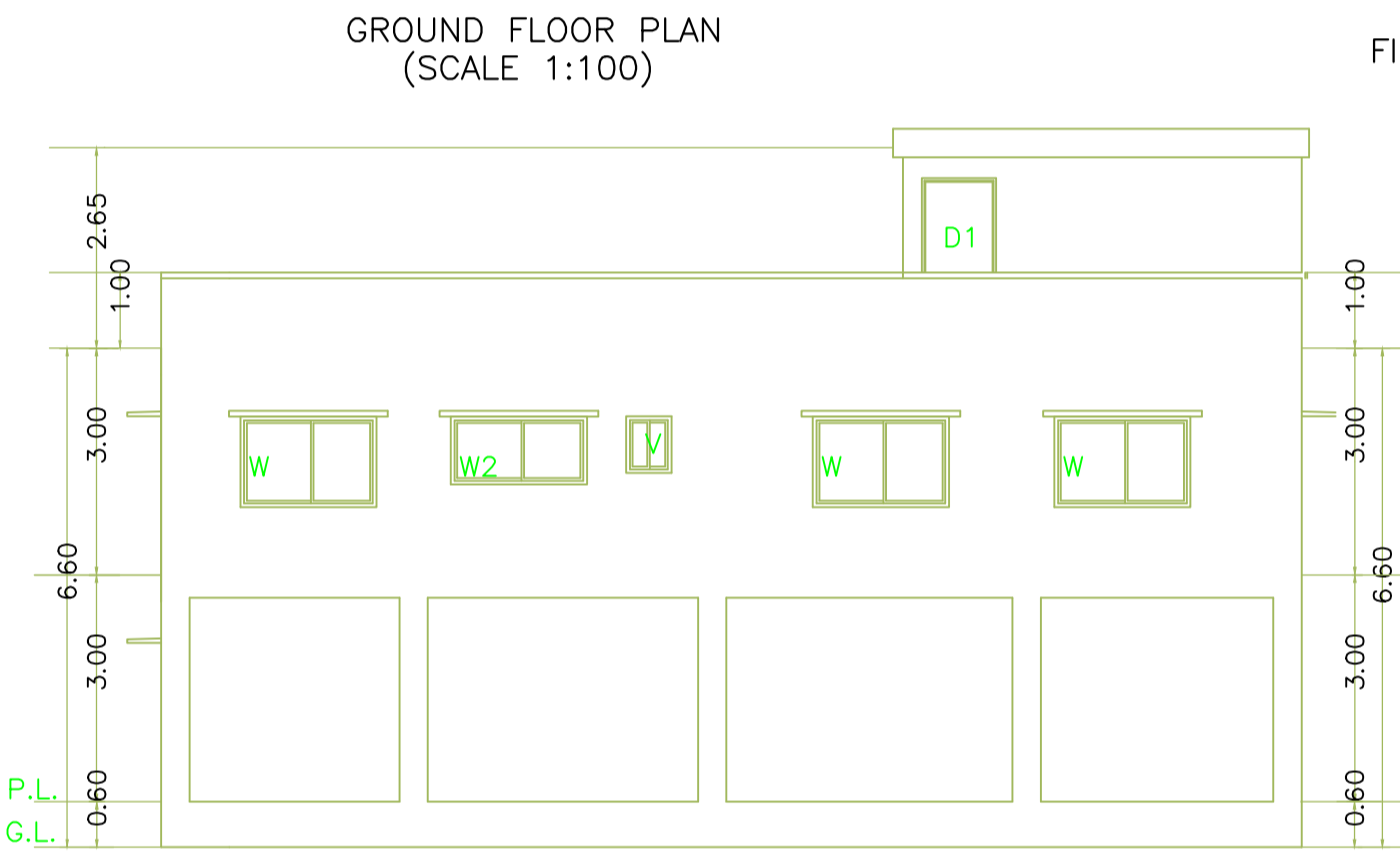
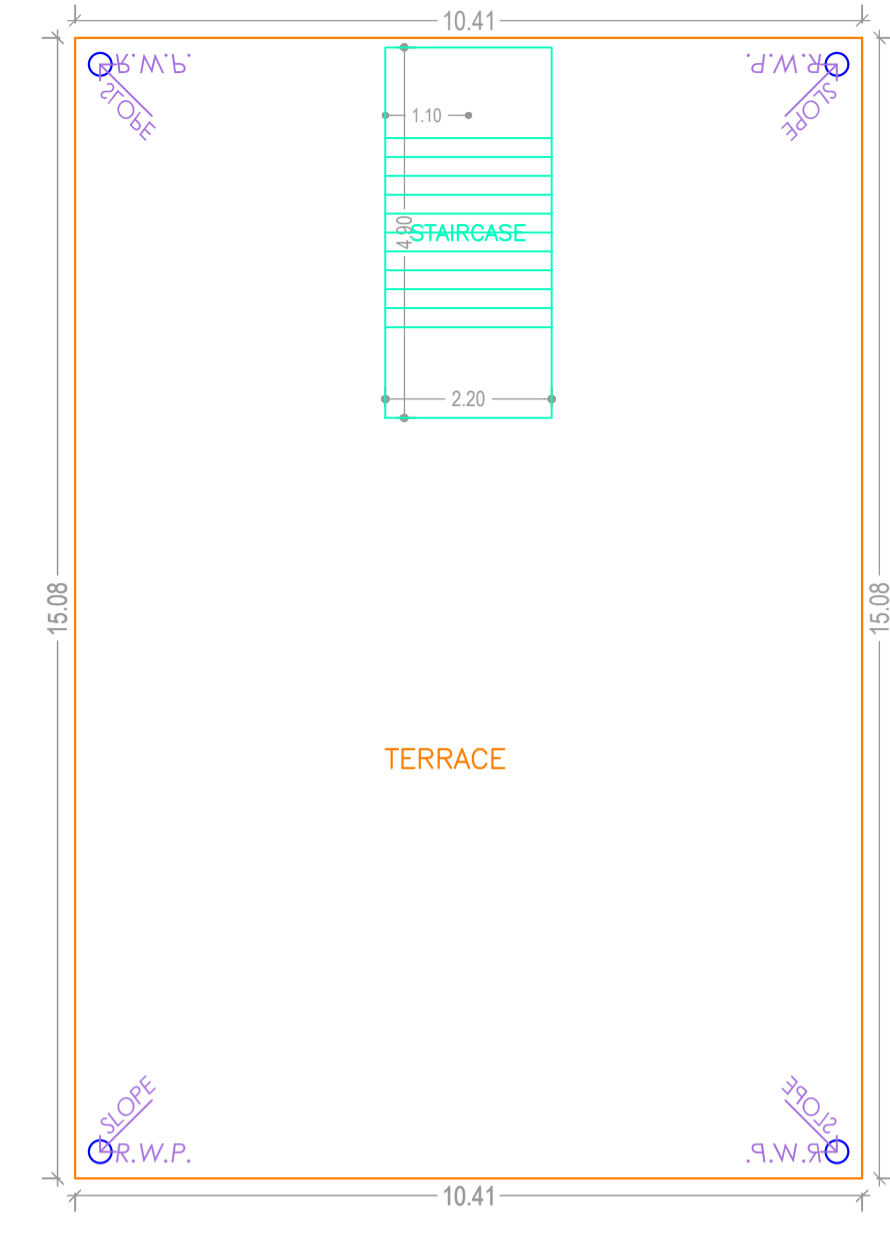
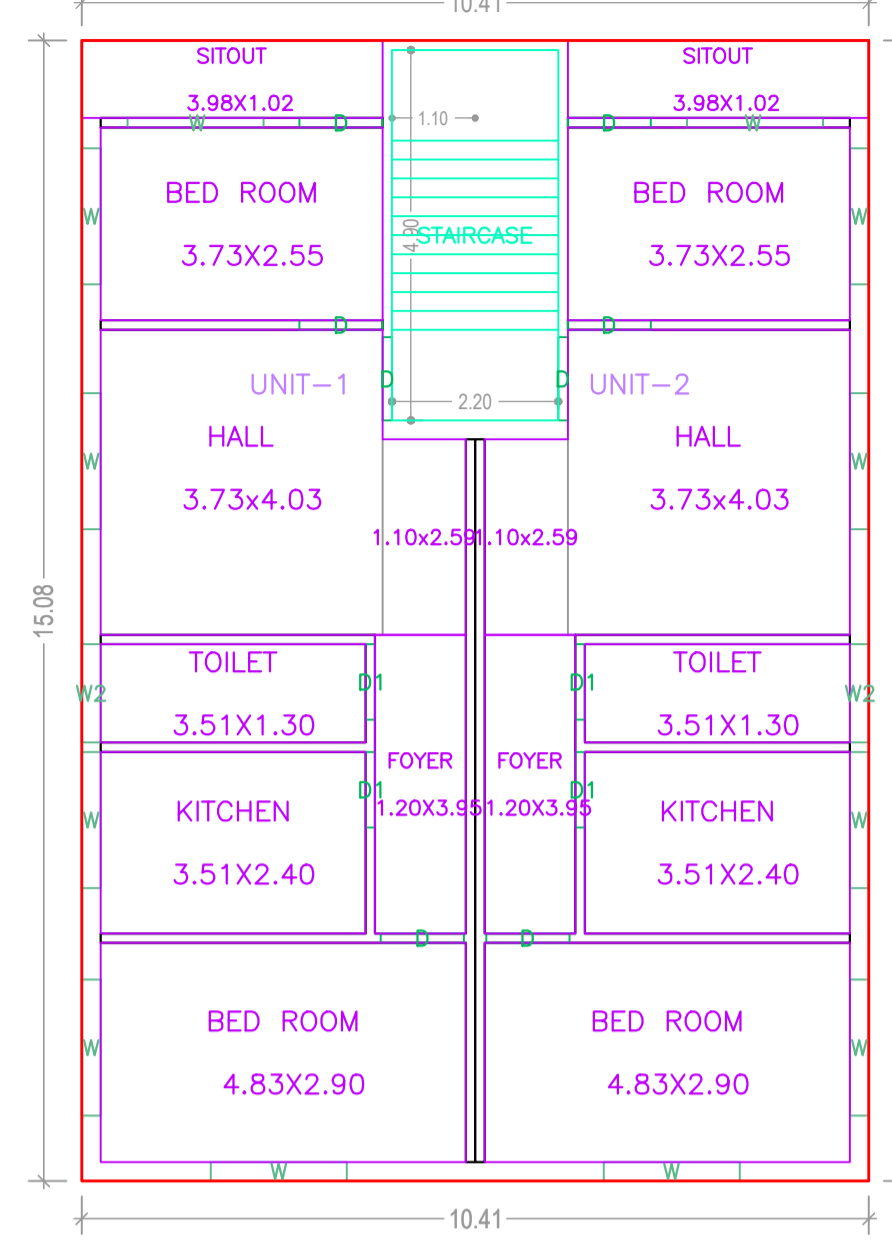
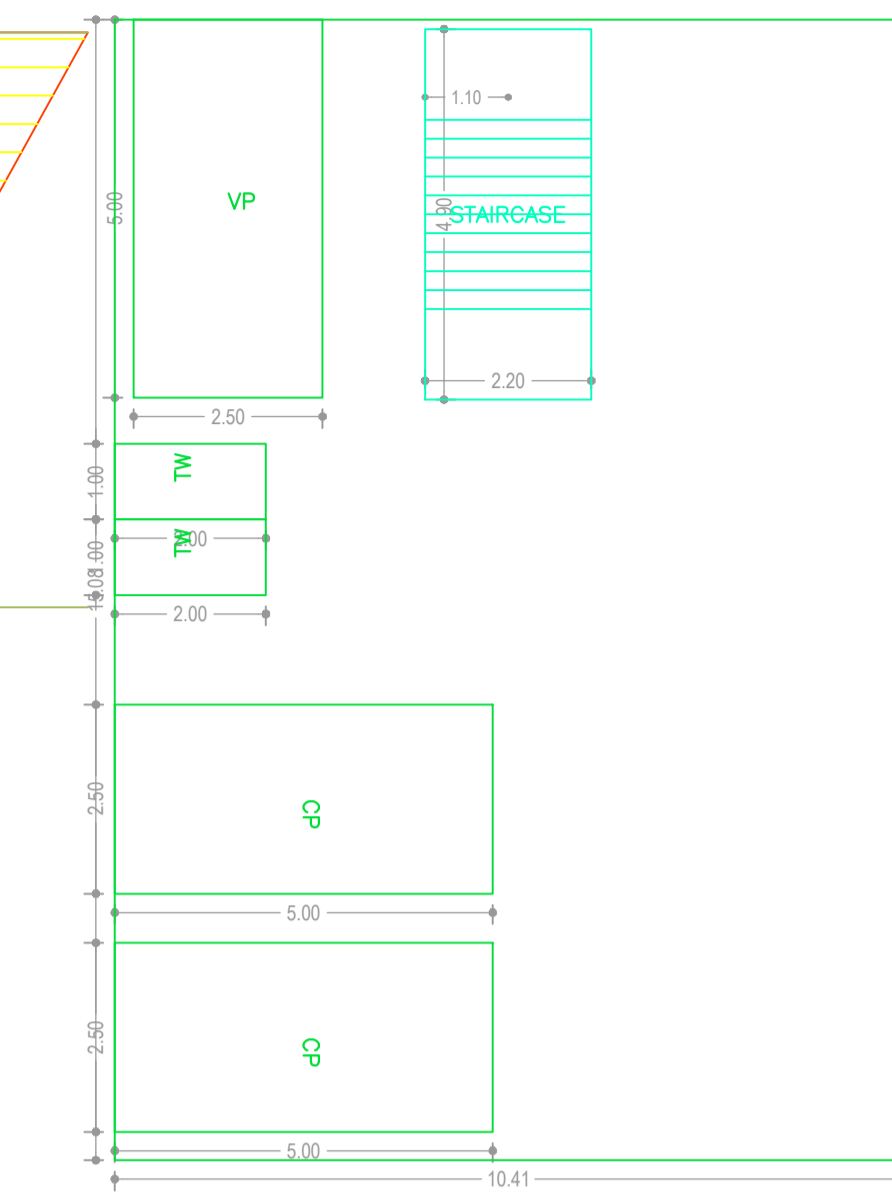
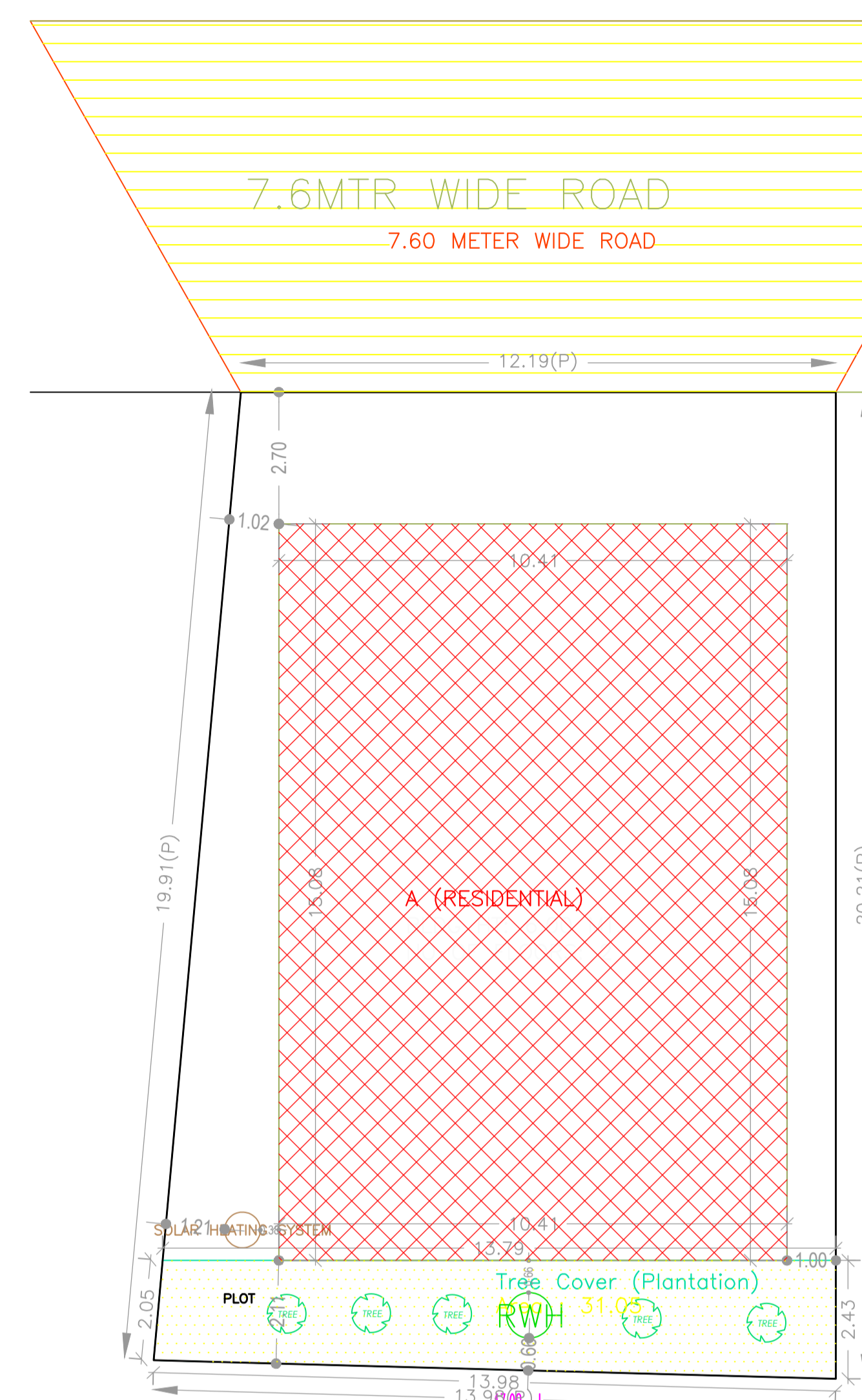

Required Parking (Table 7a)

Building Name	Type	SubUse	Area (Sq.mt.)		Units		Car		Visitors Car		TwoWheeler	
			Reqd.	Prop.	Reqd./Unit	Prop.	Reqd./Unit	Prop.	Reqd./Unit	Prop.	Reqd./Unit	Prop.
A (RESIDENTIAL)	Residential	Bungalow/ Dwelling / Non Apartment	>0	1	2.00	1	2	-	-	-	-	-
			>0	1	2.00	-	-	1	1	-	-	-
							2	2	-	1	1	0
												2

Parking Check (Table 7b)

Vehicle Type	Reqd.		Prop.	
	No.	Area	No.	Area
Car	-	-	2	25.00
Total Car	2	25.00	2	25.00
Visitor's Car Parking	-	-	1	12.50
Total Visitor Parking	1	12.50	1	12.50
TwoWheeler	-	-	2	4.00
Total TwoWheeler	-	-	2	4.00
Other Parking	-	-	-	104.77
Total		37.50		150.27

Building :A (RESIDENTIAL)

Floor Name	Total Built Up Area (Sq.mt.)	Deductions (Area in Sq.mt.)	Proposed FAR Area (Sq.mt.)	Add Area In FAR (Sq.mt.)	Total FAR Area (Sq.mt.)	Total Consumed Additional FAR Area (Sq.mt.)	Tnmt (No.)
Ground Floor	157.05	146.27	0.00	10.78	10.78	10.78	00
First Floor	157.05	0.00	157.05	0.00	157.05	157.05	02
Terrace Floor	0.00	0.00	0.00	0.00	0.00	0.00	00
Total	314.10	146.27	157.05	10.78	167.83	167.83	02

UnitBUA Table for Building :A (RESIDENTIAL)

FLOOR	Name	UnitBUA Type	UnitBUA Area	Carpet Area	No. of Rooms	No. of Tenement
FIRST FLOOR	UNIT-1	FLAT	67.31	63.21	7	2
PLAN	UNIT-2	FLAT	67.31	63.21	7	2
Total:	-	-	134.62	126.42	14	2

FAR & Tenement Details (Table 4c-1)

Building	No. of Same Bldg	Total Built Up Area (Sq.mt.)	Deductions (Area in Sq.mt.)	Proposed FAR Area (Sq.mt.)	Add Area In FAR (Sq.mt.)	Total FAR Area (Sq.mt.)	Total Consumed Additional FAR Area (Sq.mt.)	Tnmt (No.)
A (RESIDENTIAL)	1	314.10	146.27	157.05	10.78	167.83	167.83	02
Grand Total:	1	314.10	146.27	157.05	10.78	167.83	167.83	02

Building USE/SUBUSE Details

Building Name	Building Use	Building SubUse	Building Structure
A (RESIDENTIAL)	Residential	Bungalow/ Dwelling / Non Apartment	Non-Highrise

COLOR INDEX

PLOT BOUNDARY	Black
ABUTTING ROAD	Red
PROPOSED CONSTRUCTION	Green
COMMON PLOT	Yellow
ROAD WIDENING AREA	Blue
EXISTING (To be retained)	Orange
EXISTING (To be demolished)	Grey

Buildingwise Floor FAR Details

Floor Name	Building Name A (RESIDENTIAL)		Total	
	Proposed Built Up Area (Sq.mt.)	Proposed FAR Area (Sq.mt.)	Total Proposed Built Up Area (Sq.mt.)	Total FAR Area (Sq.mt.)
Ground Floor	157.05	10.78	157.05	10.78
First Floor	157.05	157.05	157.05	157.05
Terrace Floor	0.00	0.00	0.00	0.00
Total:	314.10	167.83	314.10	167.83

SCHEDULE OF DOOR:

BUILDING NAME	NAME	LENGTH	HEIGHT	NOS
A (RESIDENTIAL)	D1	1.00	2.10	04
A (RESIDENTIAL)	D	1.10	2.10	08

SCHEDULE OF WINDOW/VENTILATION:

BUILDING NAME	NAME	LENGTH	HEIGHT	NOS
A (RESIDENTIAL)	W2	1.30	0.90	02
A (RESIDENTIAL)	W	1.80	1.20	12

LTP NAME AND SIGNATURE: UDIT RAJ, DNP/ARC/0002/2021

STRUCTURAL ENG'S NAME AND SIGNATURE: _____

BUILDER NAME AND SIGNATURE: _____

DIGITAL SIGNATURE: _____