

Proposal Basic Information

Proposal File No.	DNP/BP/0005/W13/2023
Owner Name	NIRMAL KUMAR SAHA AND SUDHA SAHA
Khata No.	17/20
Plot No.	1058/P
Village Name	Dumka Town
Use	Residential
SubUse	Bungalow/ Dwelling / Non Apartment

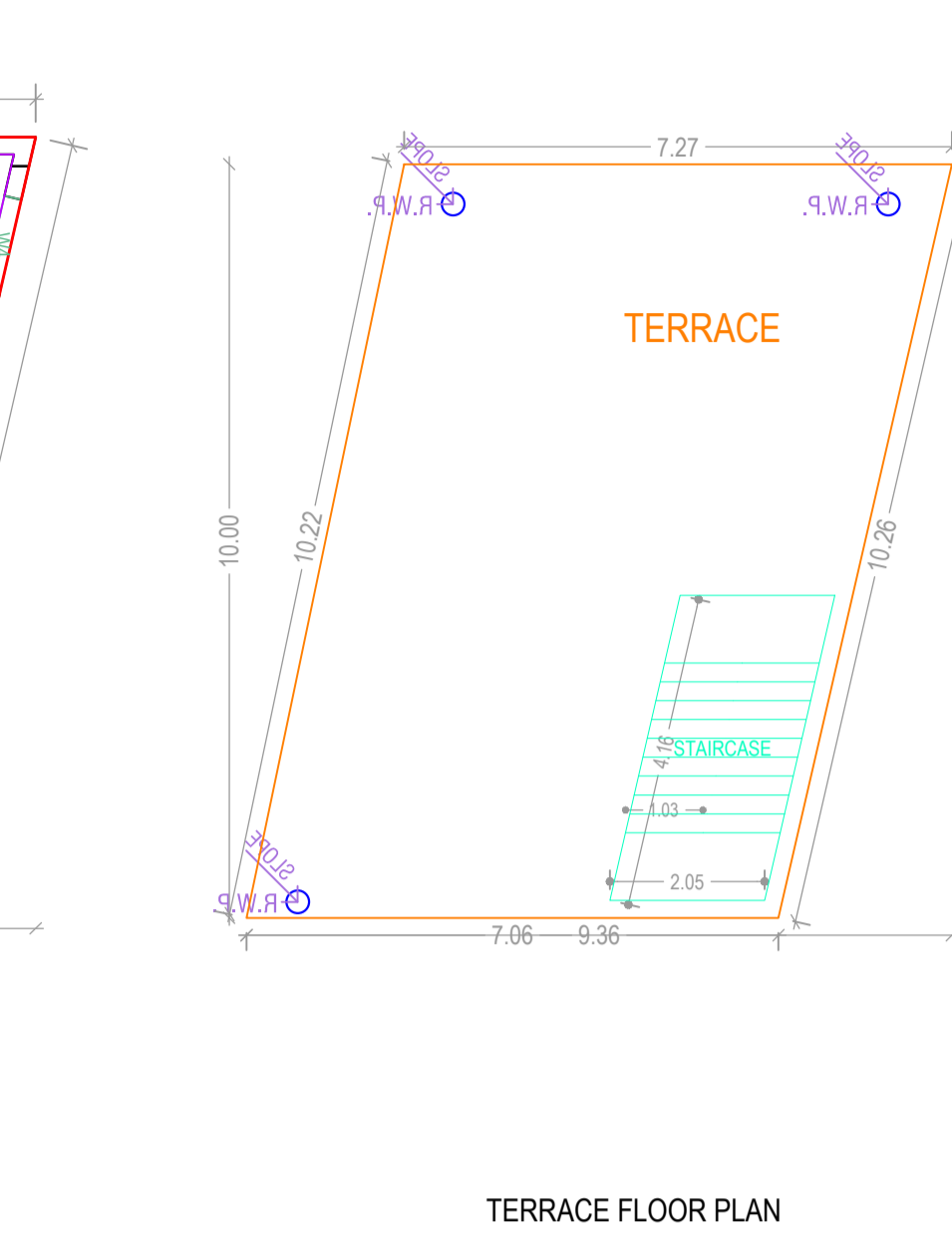
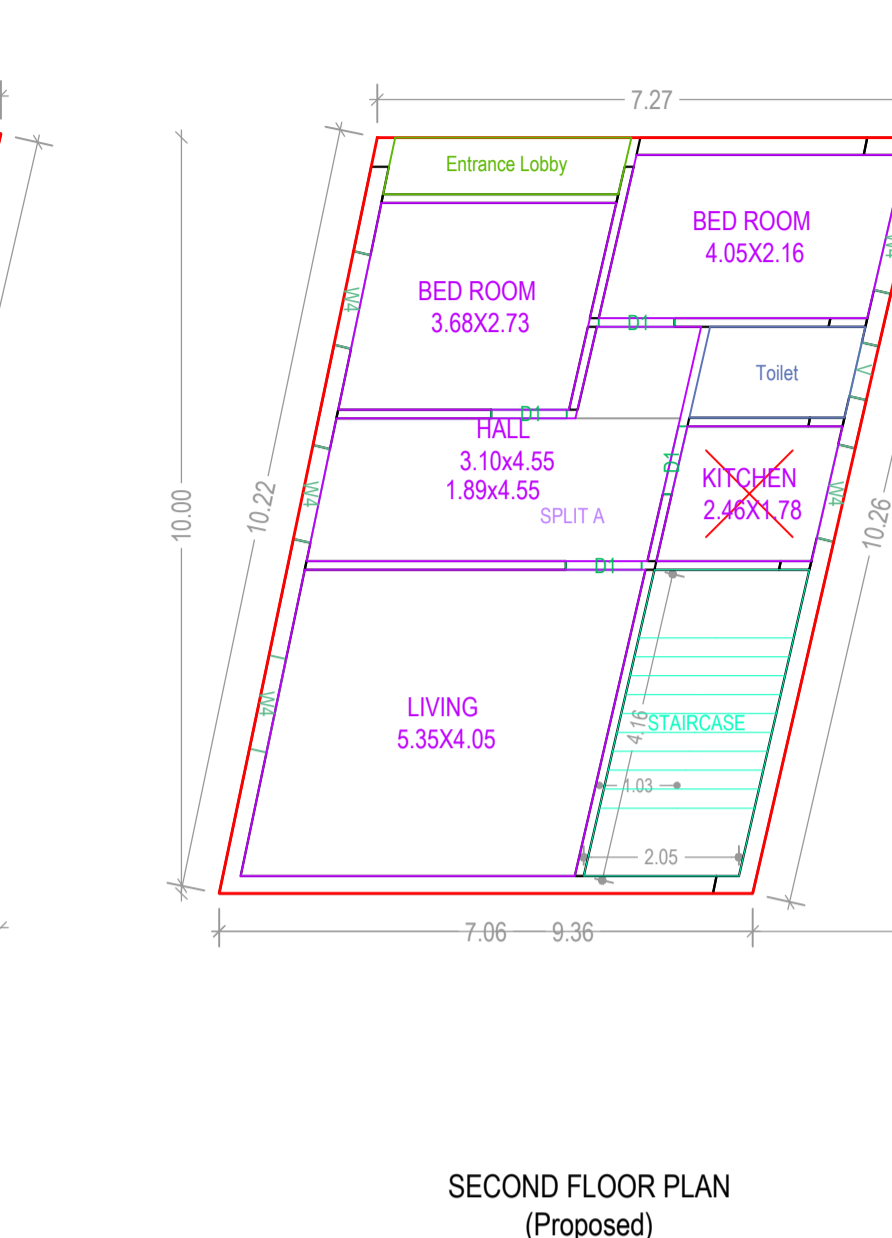
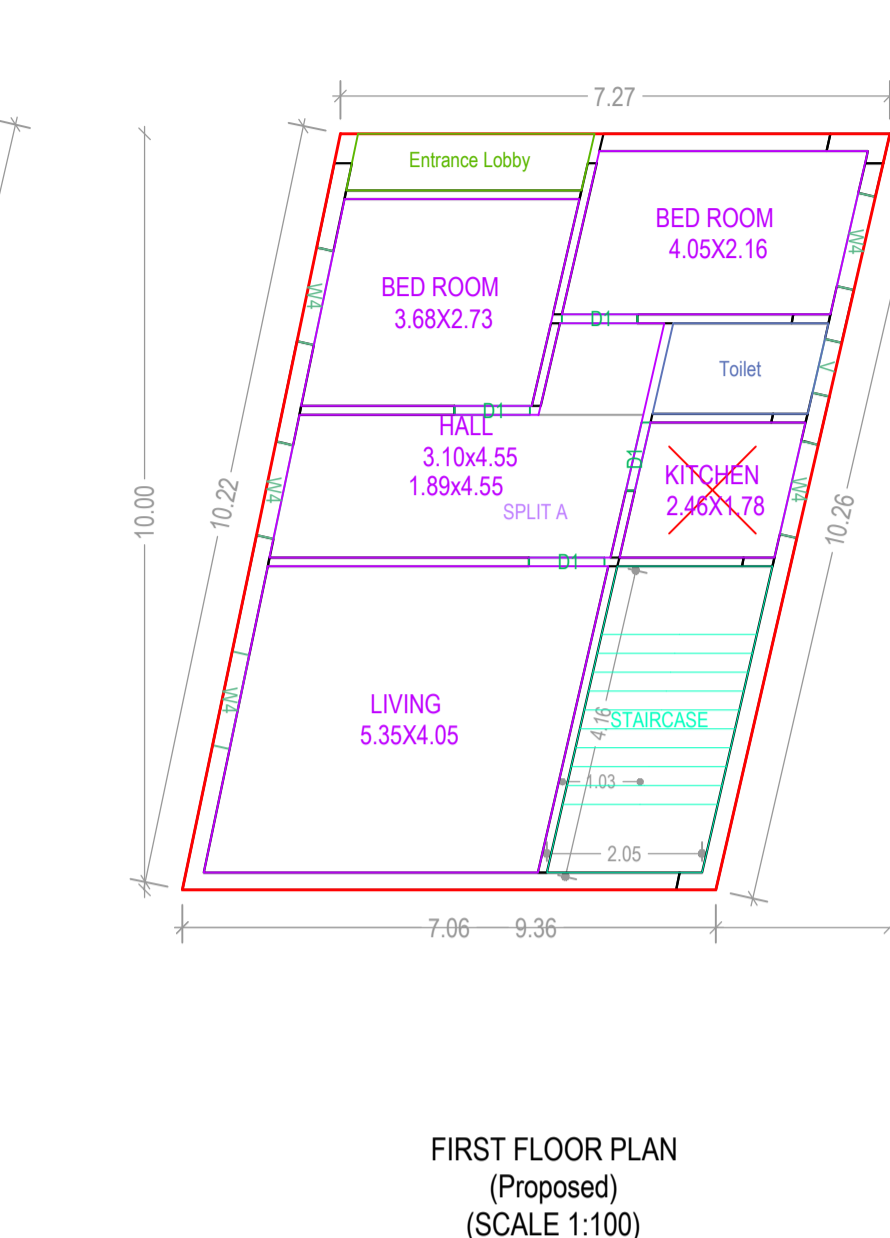
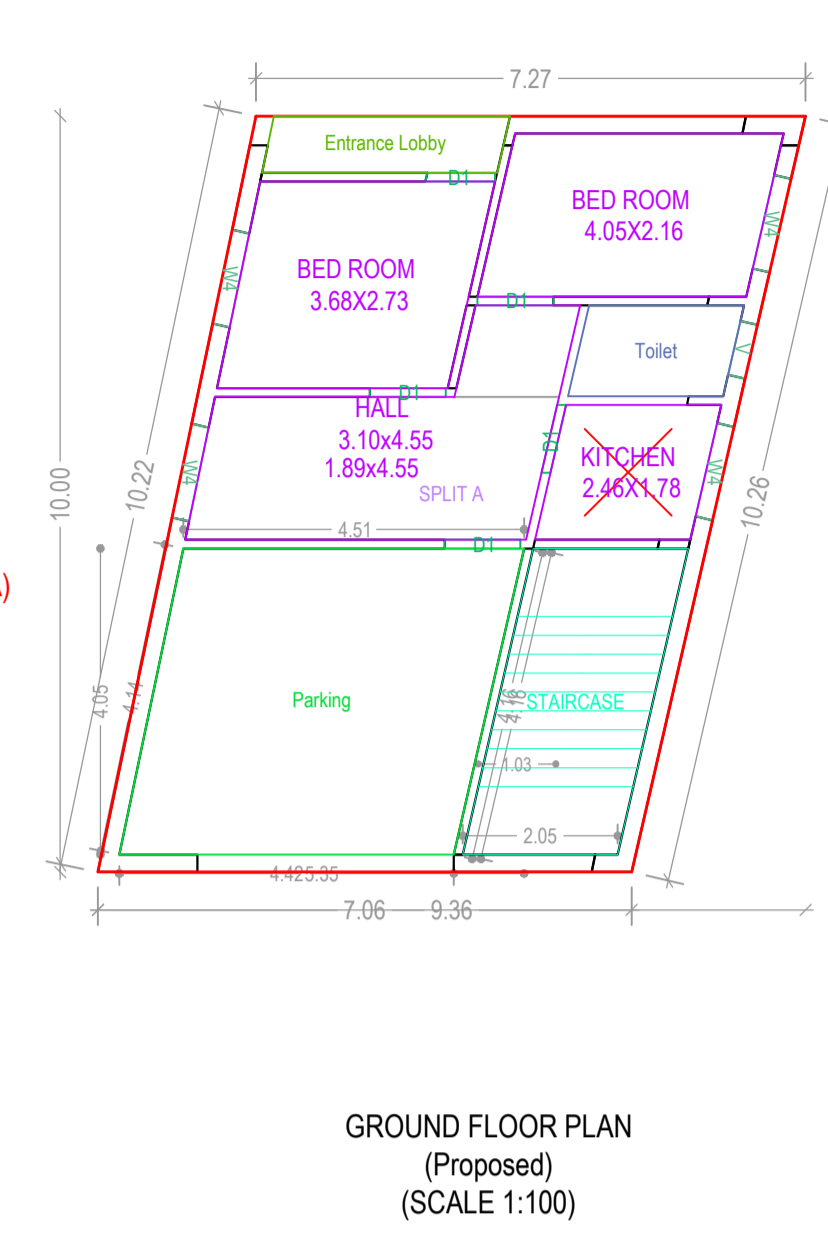
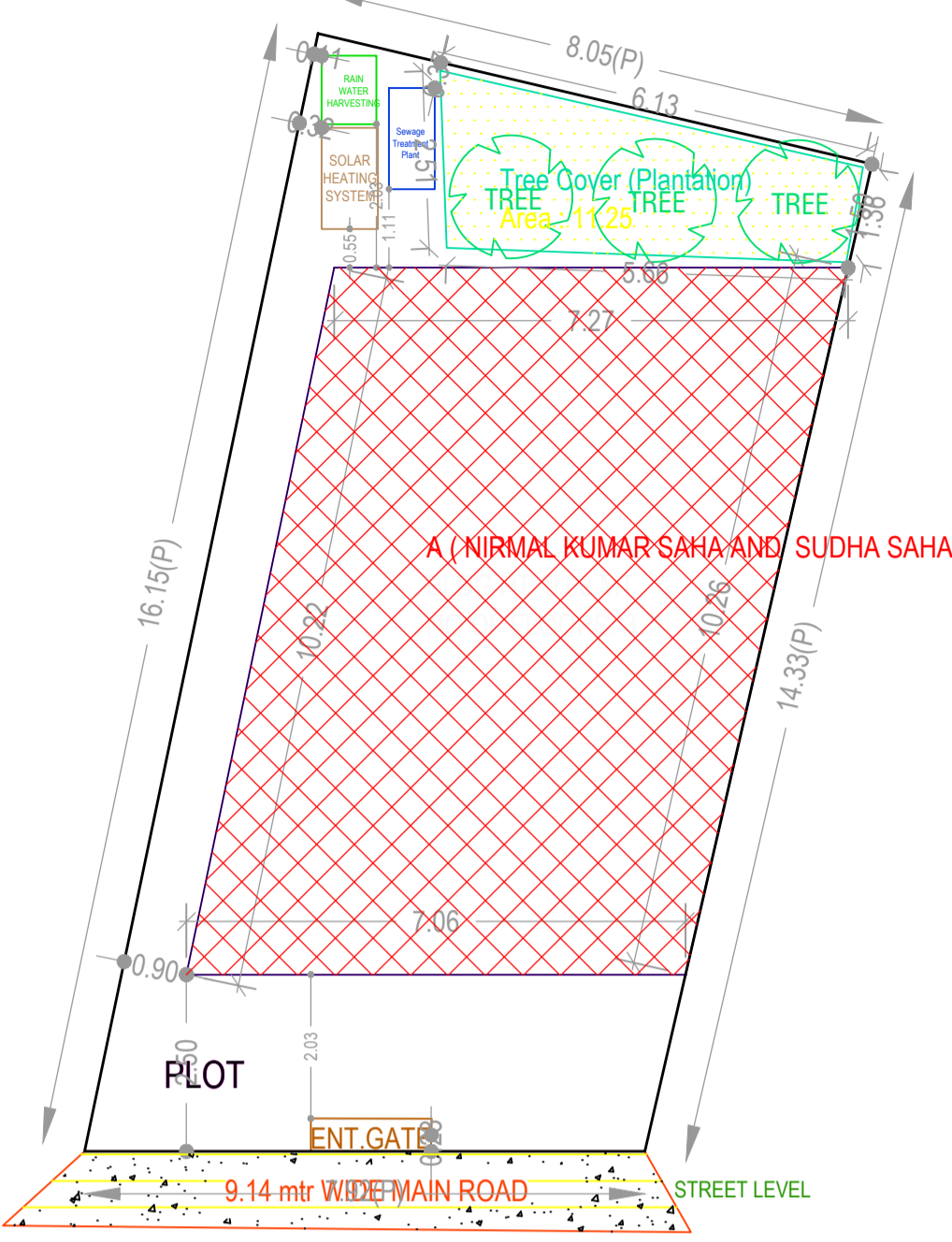

AREA STATEMENT DUMKA NAGAR PARISHAD	VERSION NO.: 1.0.68	SQ. MT.
PROJECT DETAIL:	VERSION DATE: 16/10/2020	
Region: JHARKHAND URBAN LOCAL BODIES	Plot Use: Residential	
District: DUMKA	Plot SubUse: Bungalow/ Dwelling / Non Apartment	
Authority: DUMKA NAGAR PARISHAD	PlotNearbyReligiousStructure: NA	
Inward No: DNP/BP/0005/W13/2023	Plot/SubPlot No: 1058/P	
Application Type: General Proposal	North: Plot No. - AFTER ALLEY GOPI CHOURASIA	
Project Type: Building Permission	South: Plot No. - PART OF 1058	
Nature of Development: New	East: Road Width - 9.14	
Location of Development Area: Old Area	West: Plot No. - PART OF 1058	
AREA DETAILS:		
AREA OF PLOT (Minimum)	(A)	120.28
NET AREA OF PLOT(Gross Plot Area - Deduction from Gross Plot area)	(A-Deductions)	120.28
Deduction for Balance Plot Area(from Gross Plot Area)		
Common Plot		11.25
Total		11.25
BALANCE AREA OF PLOT(Net Plot Area - Recreational/Amenity space)	(A-Deductions)	109.03
PLOT AREA FOR COVERAGE(Net Plot Area)	(A-Deductions)	120.28
Plot Area for FAR (Net Plot Area - Road Widening Area)	(A-Deductions)	120.28
COVERAGE CHECK		
Permissible Coverage area (70.00 %)		84.20
Proposed Coverage Area (59.55 %)		71.63
Total Prop. Coverage Area (59.55 %)		71.63
Balance coverage area (10.45 %)		12.57
FAR CHECK		
Perm. FAR Area (2.500)		300.70
Total Perm. FAR area		300.70
Residential FAR		200.48
Proposed FAR Area		200.48
Total Proposed FAR Area		200.48
Consumed FAR (Factor)		1.67
Balance FAR Area		100.22
BUILT UP AREA CHECK		
Total Proposed BuiltUp Area		214.89
ARCHITECT (Regd)		SURIYA CHOUDHURY
ENGINEER (Regd)		
SUPERVISOR (Regd)		
OWNER (Regd)		NIRMAL KUMAR SAHA AND SUDHA SAHA
DEVELOPMENT AUTHORITY		LOCAL BODY

SITE PLAN

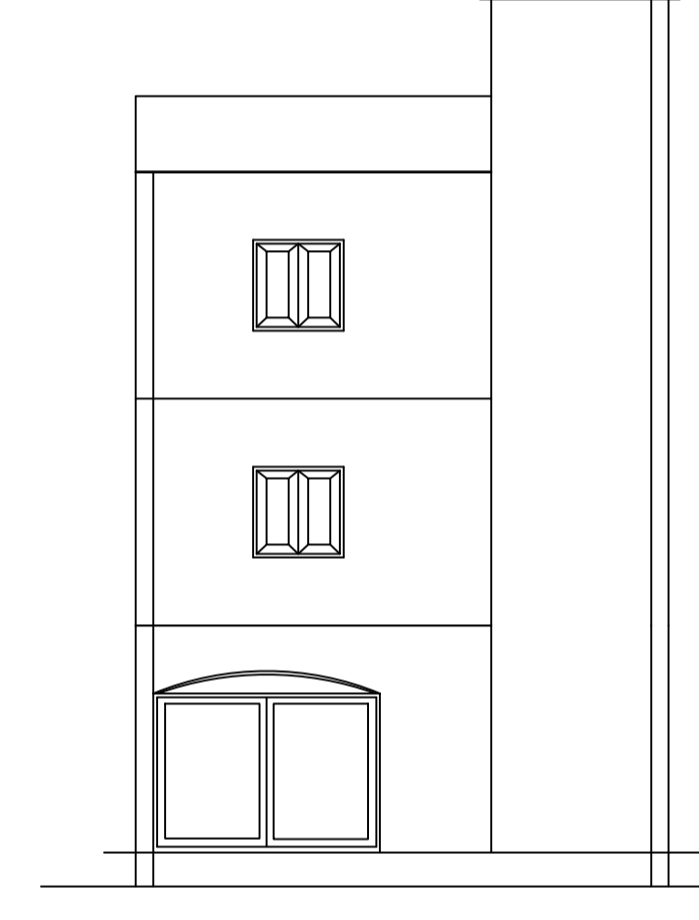
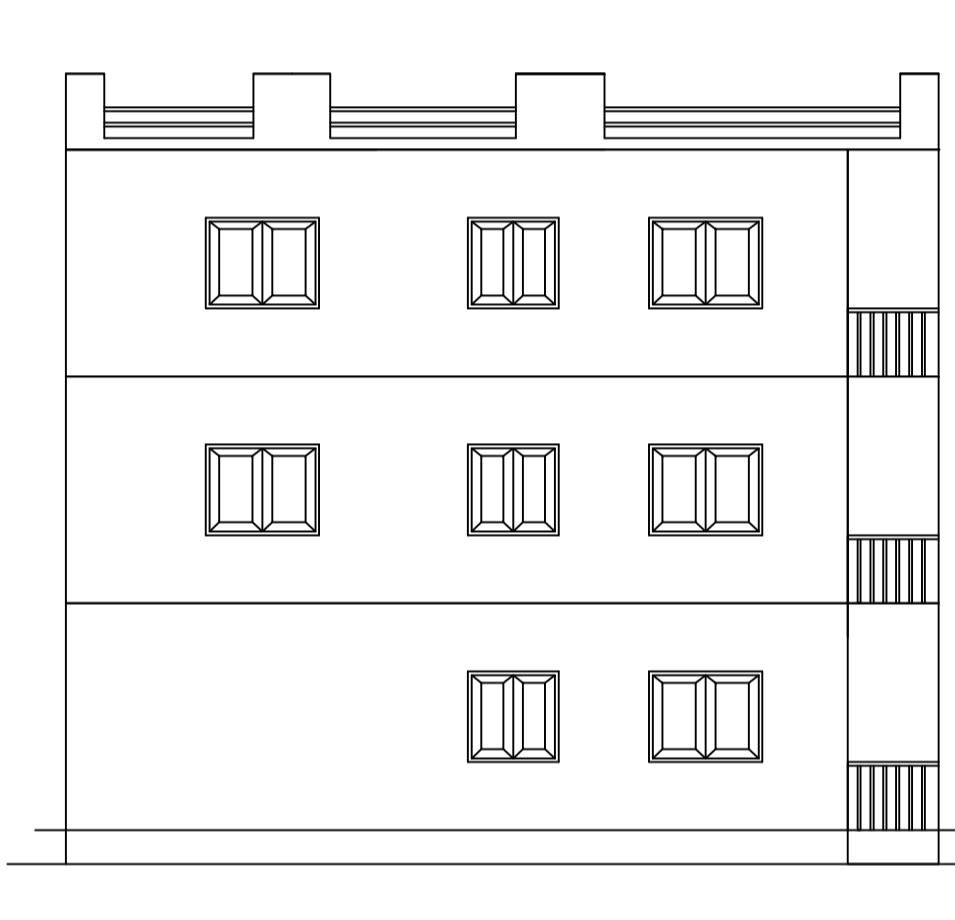
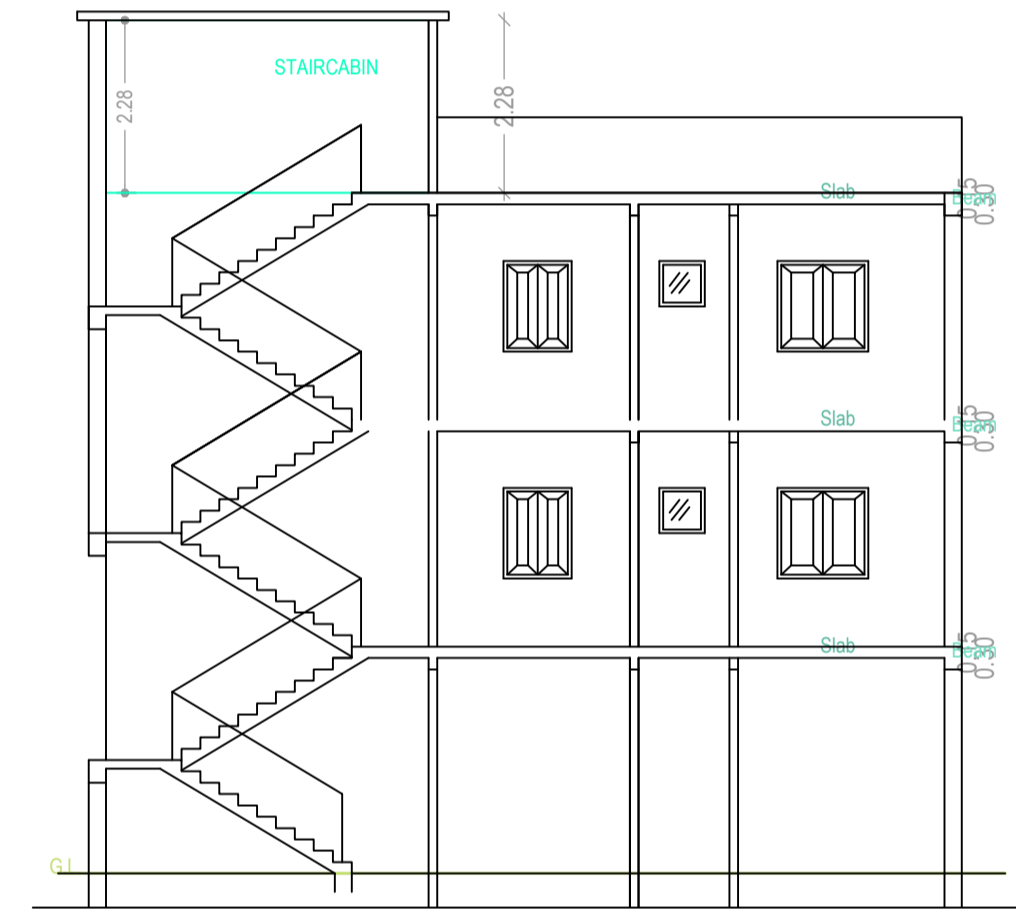
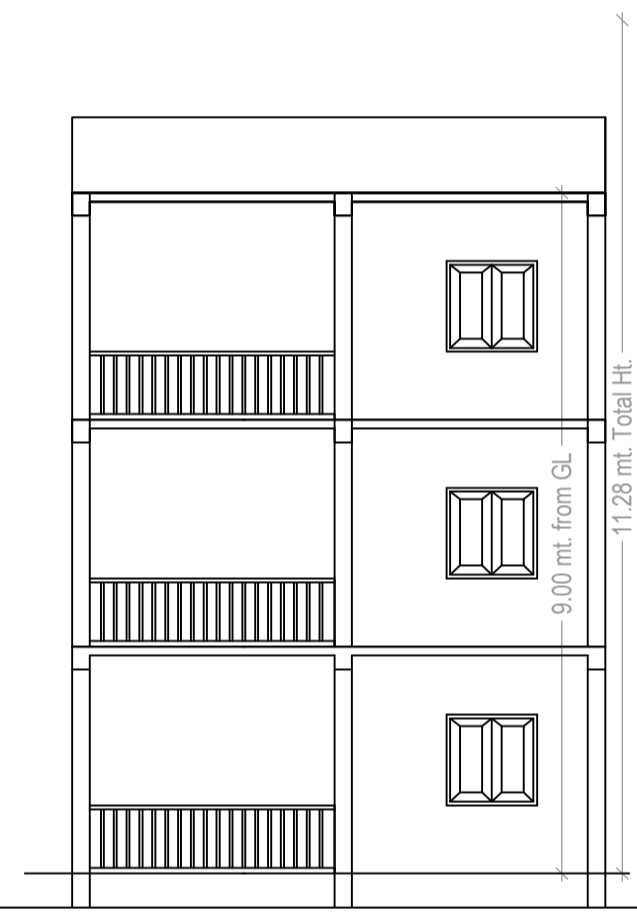

SECTION AT X-X

SECTION AT Y-Y

SIDE ELEVATION

FRONT ELEVATION

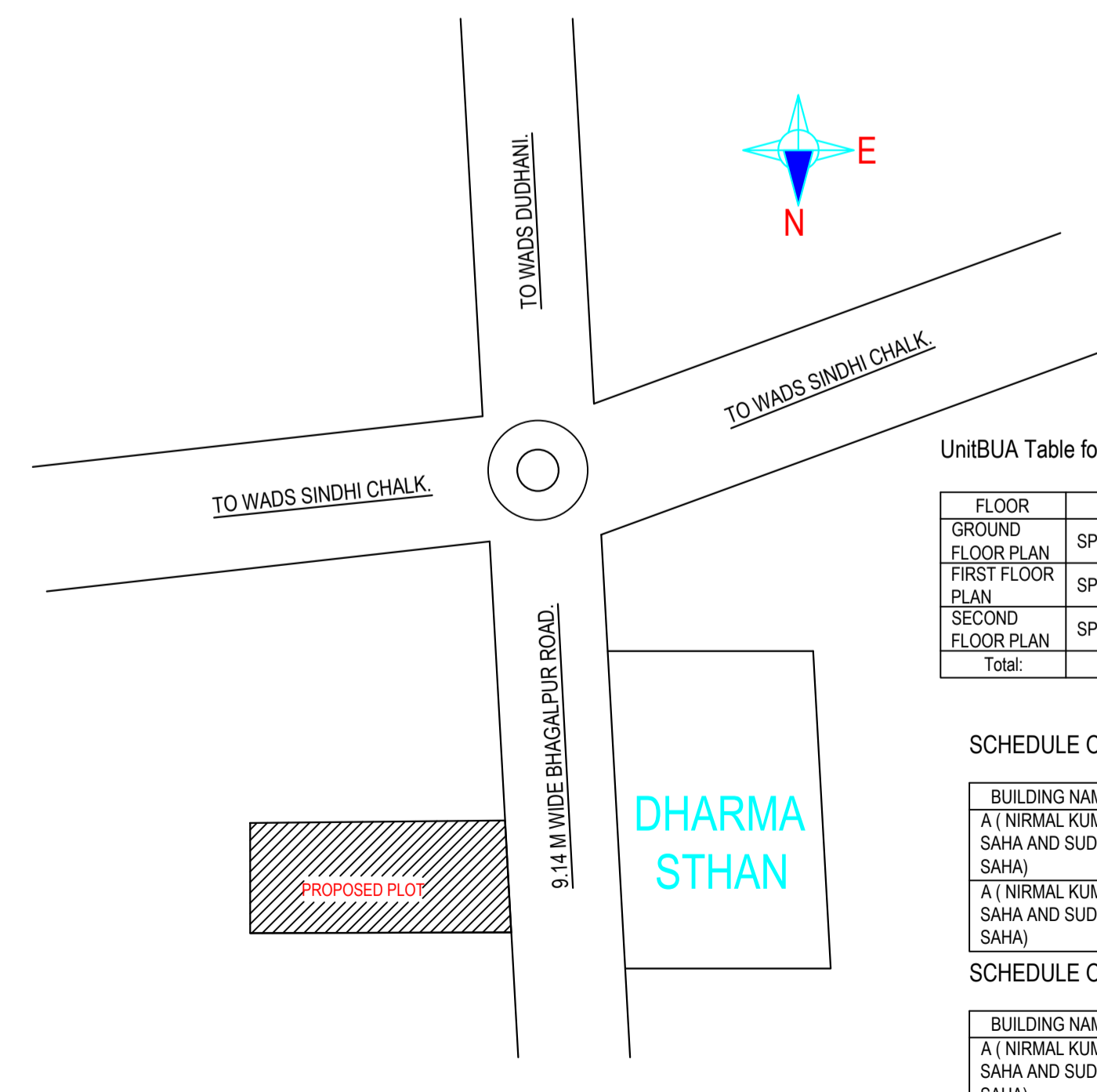

UniBUA Table for Building :A (NIRMAL KUMAR SAHA AND SUDHA SAHA)

FLOOR	Name	UniBUA Type	UniBUA Area	Carpet Area	No. of Rooms	No. of Tenement
GROUND FLOOR PLAN	SPLIT A	FLAT	207.49	183.68	4	1
FIRST FLOOR PLAN	SPLIT A	FLAT	0.00	0.00	5	0
SECOND FLOOR PLAN	SPLIT A	FLAT	0.00	0.00	5	0
Total:	-	-	207.49	183.68	14	1

SCHEDULE OF DOOR:

BUILDING NAME	NAME	LENGTH	HEIGHT	NOS
A (NIRMAL KUMAR SAHA AND SUDHA SAHA)	D1	0.92	2.10	04
A (NIRMAL KUMAR SAHA AND SUDHA SAHA)	D1	1.00	2.10	09

SCHEDULE OF WINDOW/VENTILATION:

BUILDING NAME	NAME	LENGTH	HEIGHT	NOS
A (NIRMAL KUMAR SAHA AND SUDHA SAHA)	W4	1.27	2.70	14

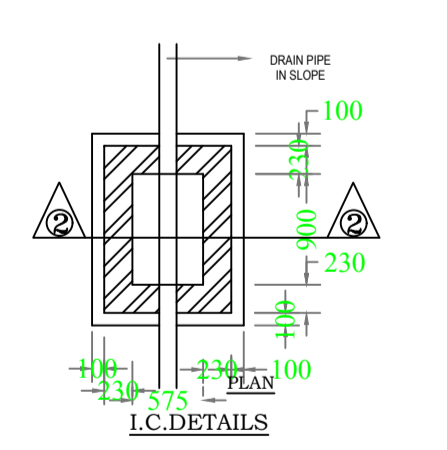
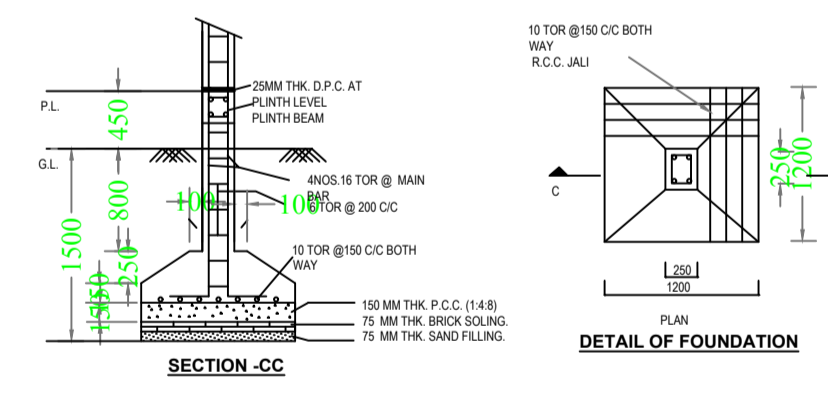
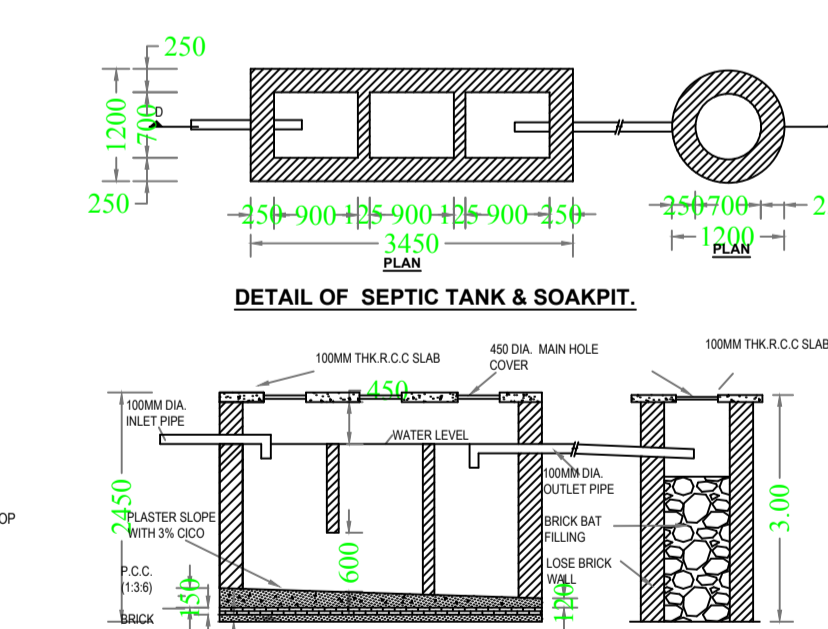
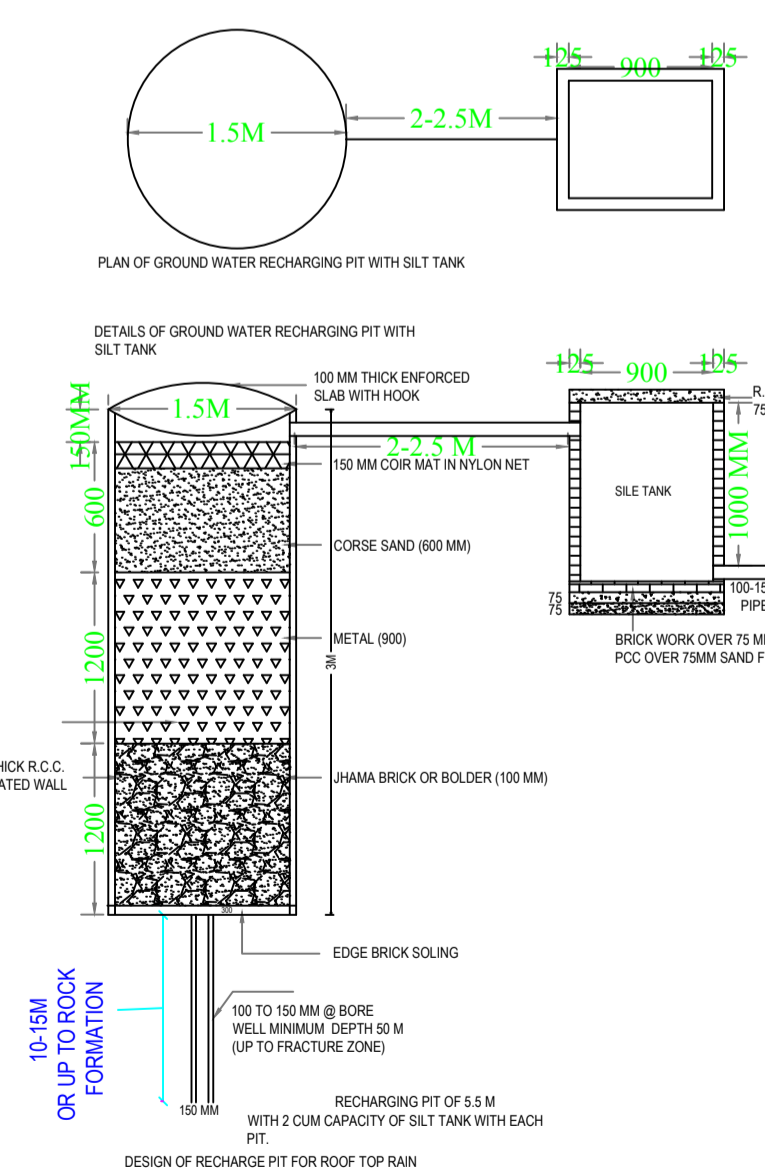

Building :A (NIRMAL KUMAR SAHA AND SUDHA SAHA)

Floor Name	Total Built Up Area (Sq.mt.)	Deductions (Area in Sq.mt.)	Proposed FAR Area (Sq.mt.)	Total FAR Area (Sq.mt.)	Total Consumed Additional FAR Area (Sq.mt.)	Tnmt (No.)
Ground Floor	71.63	4.80	66.83	66.83	66.83	01
First Floor	71.63	4.80	66.83	66.83	66.83	00
Second Floor	71.63	4.80	66.83	66.83	66.83	00
Terrace Floor	0.00	0.00	0.00	0.00	0.00	00
Total :	214.89	14.40	200.49	200.49	200.49	01
Total Number of Same Buildings :	1					
Total :	214.89	14.40	200.49	200.49	200.49	01

COLOR INDEX

PLOT BOUNDARY	Black
ABUTTING ROAD	Red
PROPOSED CONSTRUCTION	Green
COMMON PLOT	Yellow
ROAD WIDENING AREA	Blue
EXISTING (To be retained)	Orange
EXISTING (To be demolished)	Light Blue

Buildingwise Floor FAR Details

Floor Name	Building Name		Total	
	A (NIRMAL KUMAR SAHA AND SUDHA SAHA)	Proposed FAR Area (Sq.mt.)	Total Proposed Built Up Area (Sq.mt.)	Total FAR Area (Sq.mt.)
Ground Floor	71.63	66.83	71.63	66.83
First Floor	71.63	66.83	71.63	66.83
Second Floor	71.63	66.83	71.63	66.83
Terrace Floor	0.00	0.00	0.00	0.00
Total :	214.89	200.49	214.89	200.49

Building USE/SUBUSE Details

Building Name	Building Use	Building SubUse	Building Structure
A (NIRMAL KUMAR SAHA AND SUDHA SAHA)	Residential	Bungalow/ Dwelling / Non Apartment	Non-Highrise

FAR & Tenement Details (Table 4c-1)

Building	No. of Same Bldg	Total Built Up Area (Sq.mt.)	Deductions (Area in Sq.mt.)		Total FAR Area (Sq.mt.)	Total Consumed Additional FAR Area (Sq.mt.)	Tnmt (No.)
			Accessory Use	Resi.			
A (NIRMAL KUMAR SAHA AND SUDHA SAHA)	1	214.89	14.40	200.49	200.49	200.49	01
Grand Total :	1	214.89	14.40	200.49	200.49	200.49	01

LTP NAME AND SIGNATURE	STRUCTURAL ENG'S NAME AND SIGNATURE	BUILDER NAME AND SIGNATURE	DIGITAL SIGNATURE
SURIYA CHOUDHURY DNP/ENG/0002/2018			