

GROUND FLOOR PLAN (Proposed) (SCALE 1:100)

Building :A (SMT SAROJ KERKETTA)

Floor Name	Total Built Up Area (Sq.mt.)	Proposed FAR Area (Sq.mt.) Resi.	Total FAR Area (Sq.mt.)	Total Consumed Additional FAR Area (Sq.mt.)	Tnmt (No.)
Ground Floor	96.67	96.67	96.67	96.67	01
First Floor	96.67	96.67	96.67	96.67	00
Terrace Floor	0.00	0.00	0.00	0.00	00
Total :	193.34	193.34	193.34	193.34	01
Total Number of Same Buildings :	1				
Total :	193.34	193.34	193.34	193.34	01

SITE PLAN

Building USE/SUBUSE Details

Building Name	Building Use	Building SubUse	Building Structure
A (SMT SAROJ KERKETTA)	Residential	Residential Bldg/Apartment	Non-Highrise

FAR & Tenement Details (Table 4c-1)

Building	No. of Same Bldg	Total Built Up Area (Sq.mt.)	Proposed FAR Area (Sq.mt.) Resi.	Total FAR Area (Sq.mt.)	Total Consumed Additional FAR Area (Sq.mt.)	Tnmt (No.)
A (SMT SAROJ KERKETTA)	1	193.34	193.34	193.34	193.34	01
Grand Total :	1	193.34	193.34	193.34	193.34	01

Buildingwise Floor FAR Details

Floor Name	Building Name A (SMT SAROJ KERKETTA)		Total	
	Proposed Built Up Area (Sq.mt.)	Proposed FAR Area (Sq.mt.)	Total Proposed Built Up Area (Sq.mt.)	Total FAR Area (Sq.mt.)
Ground Floor	96.67	96.67	96.67	96.67
First Floor	96.67	96.67	96.67	96.67
Terrace Floor	0.00	0.00	0.00	0.00
Total :	193.34	193.34	193.34	193.34

UnitBUA Table for Building :A (SMT SAROJ KERKETTA)

FLOOR	Name	UnitBUA Type	UnitBUA Area	Carpet Area	No. of Rooms	No. of Tenement
GROUND FLOOR PLAN	SPLIT SMT SAROJ KERKETTA	FLAT	173.96	165.36	8	1
FIRST FLOOR PLAN	SPLIT SMT SAROJ KERKETTA	FLAT	0.00	0.00	8	0
Total:	-	-	173.96	165.36	16	1

AREA STATEMENT GUMLA NAGAR PARISHAD		VERSION NO. :1.0.22
PROJECT DETAIL:		VERSION DATE: 28/09/2017
Region: JHARKHAND URBAN LOCAL BODIES	Plot Use: Residential	
District: GUMLA	Plot SubUse: Boarding	
Authority: GUMLA NAGAR PARISHAD	Plot/Nearby/Religious/Structure: NA	
Inward No: GUNPC/BP/0028/W08/2017	Plot/SubPlot No: 1136	
Application Type: General Proposal	North: -	
Project Type: Building Permission	South: -	
Nature of Development: New	East: -	
Location of Development Area: Old Area	West: -	
AREA DETAILS:		SQ.MT.
AREA OF PLOT (Minimum)	(A)	542.45
Deduction for NetPlot Area		
Surrender Free of Cost		24.19
Total		24.19
NET AREA OF PLOT(Gross Plot Area - Deduction from Gross Plot area)	(A-Deductions)	518.26
Deduction for Balance Plot Area(from Gross Plot Area)		
Surrender Free of Cost		24.19
Common Plot		66.42
Total		90.61
BALANCE AREA OF PLOT(Net Plot Area - Recreational/Amenity space)	(A-Deductions)	451.84
PLOT AREA FOR COVERAGE(Net Plot Area)	(A-Deductions)	518.26
Plot Area for FAR (Net Plot Area + RoadWidening Area)	(A-Deductions)	542.45
COVERAGE CHECK		
Permissible Coverage area (60.00 %)		310.96
Proposed Coverage Area (18.65 %)		96.67
Total Prop. Coverage Area (18.65 %)		96.67
Balance coverage area (41.35 %)		214.29
FAR CHECK		
Perm. FAR Area (1.20)		650.94
Total Perm. FAR area		650.94
Residential FAR		193.33
Proposed FAR Area		193.33
Total Proposed FAR Area		193.33
Consumed FAR (Factor)		0.36
Balance FAR Area		457.61
BUILT UP AREA CHECK		
Total Proposed BuiltUp Area		193.34
ARCHITECT (Regd)	DEEPAK DIWAN	
ENGINEER (Regd)		
SUPERVISOR (Regd)		
OWNER (Regd)	SAROJ KERKETTA	
DEVELOPMENT AUTHORITY	LOCAL BODY	

SCHEDULE OF DOOR:

BUILDING NAME	NAME	LENGTH	HEIGHT	NOS
A (SMT SAROJ KERKETTA)	d2	0.75	2.10	02
A (SMT SAROJ KERKETTA)	D2	0.75	2.10	02
A (SMT SAROJ KERKETTA)	d1	0.90	2.10	06
A (SMT SAROJ KERKETTA)	D1	0.90	2.10	02
A (SMT SAROJ KERKETTA)	D	1.00	2.10	02
A (SMT SAROJ KERKETTA)	D	1.05	2.13	01

SCHEDULE OF WINDOW/VENTILATION:

BUILDING NAME	NAME	LENGTH	HEIGHT	NOS
A (SMT SAROJ KERKETTA)	v	0.60	0.80	04
A (SMT SAROJ KERKETTA)	w1	1.00	1.20	06
A (SMT SAROJ KERKETTA)	w	1.50	1.20	06
A (SMT SAROJ KERKETTA)	w0	3.50	2.50	02

COLOR INDEX

PLOT BOUNDARY	Black
ABUTTING ROAD	Green
PROPOSED CONSTRUCTION	Red
COMMON PLOT	Yellow
ROAD WIDENING AREA	Blue
EXISTING (To be retained)	Blue
EXISTING (To be demolished)	Yellow

LTP NAME AND SIGNATURE	STRUCTURAL ENG'S NAME AND SIGNATURE	BUILDER NAME AND SIGNATURE
DEEPAK DIWAN GUNPC/ARC/0003/2017		

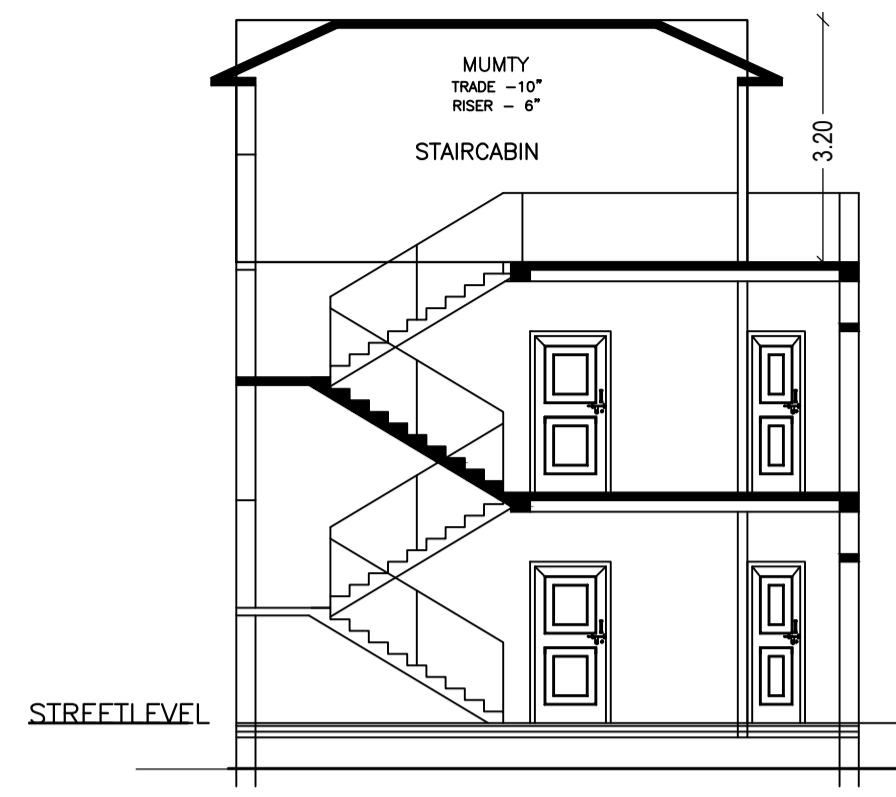

SECTION AT A-A
SCALE :- 1"=100

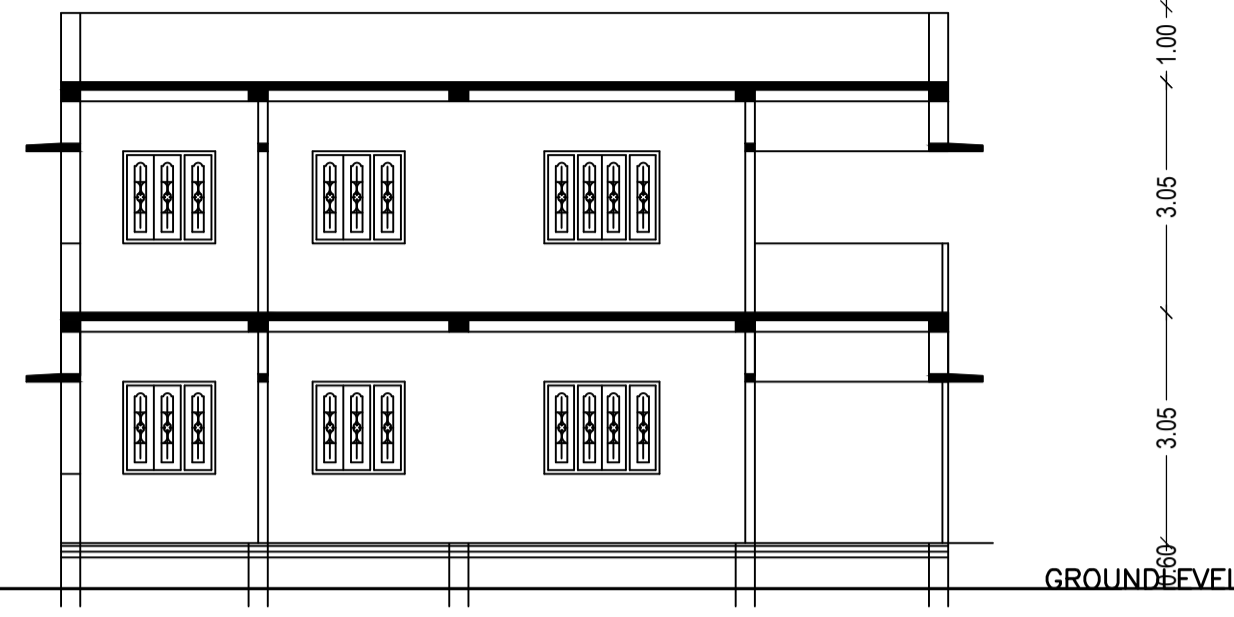

SECTION AT B-B
SCALE :- 1"=100

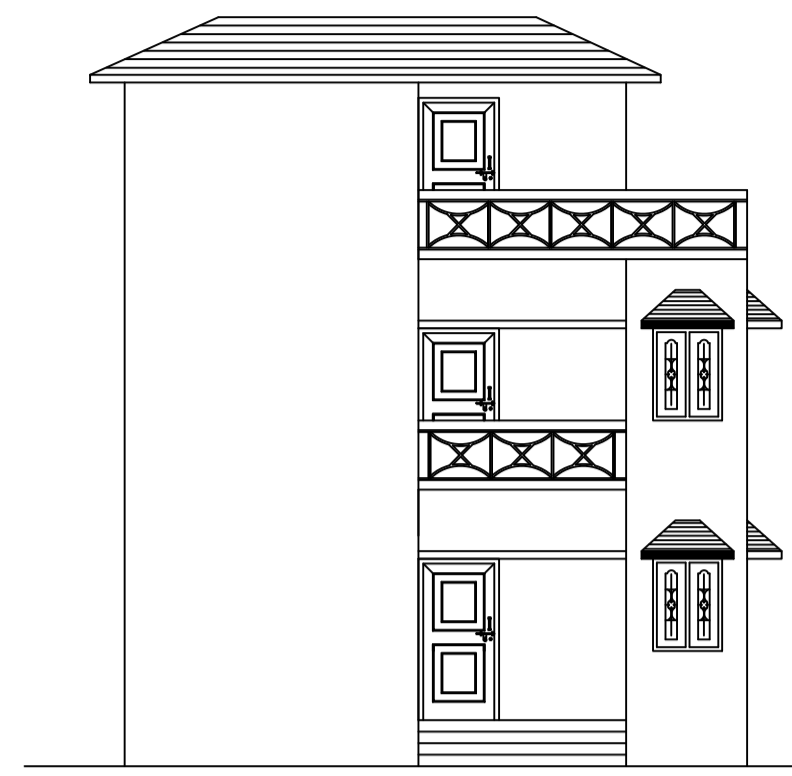

FRONT ELEVATION
SCALE :- 1"=100

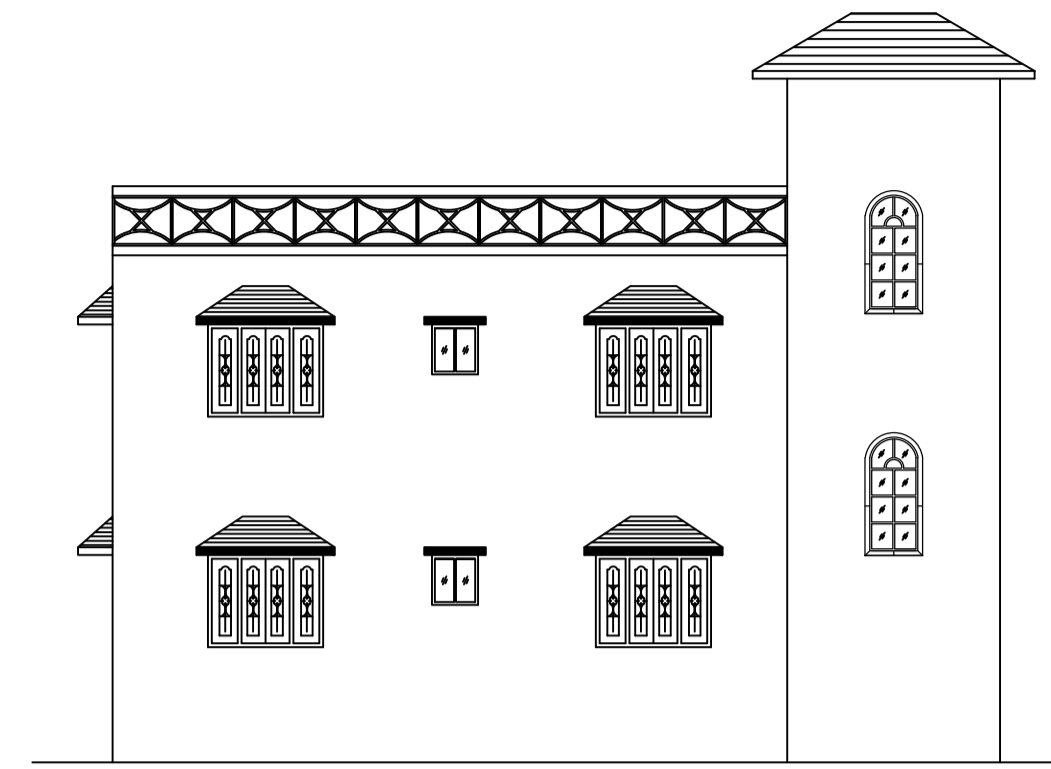

LEFT SIDE ELEVATION
SCALE :- 1"=100

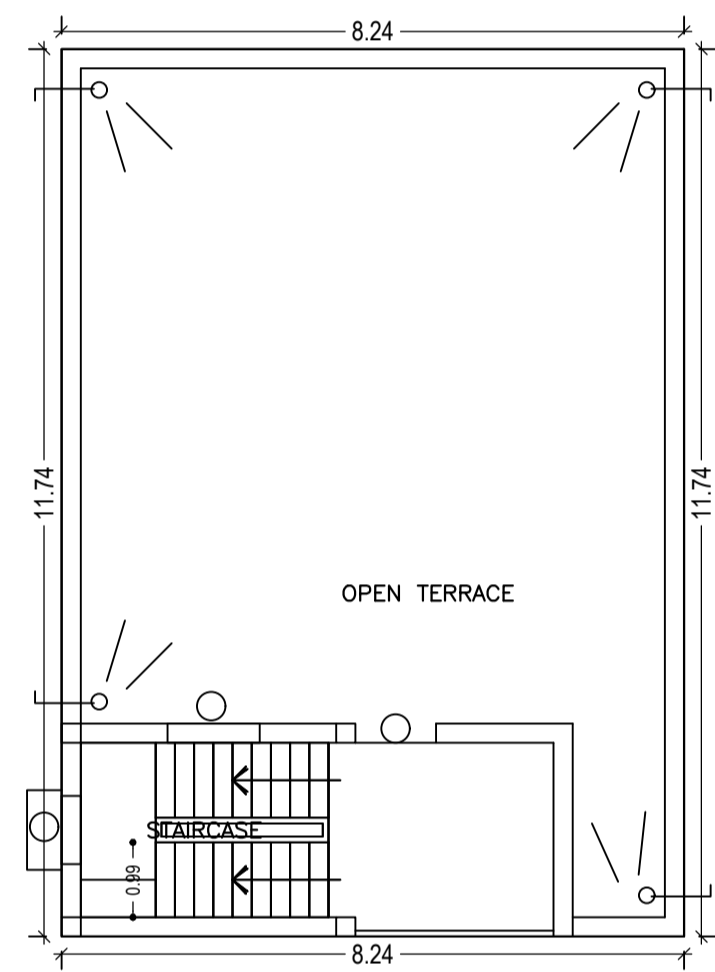

TERRACE FLOOR PLAN
(SCALE 1:100)

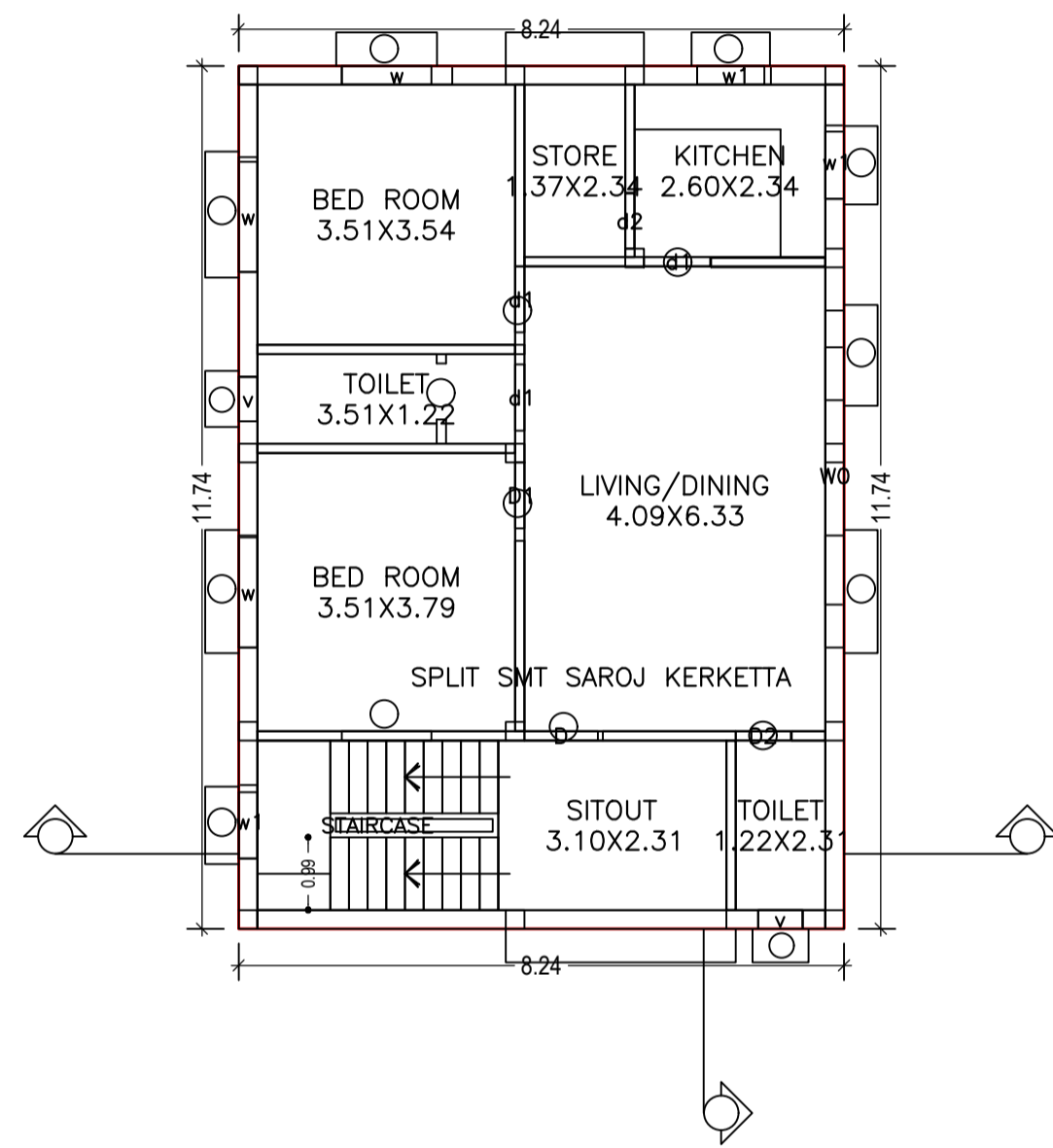

FIRST FLOOR PLAN
(Proposed)
(SCALE 1:100)

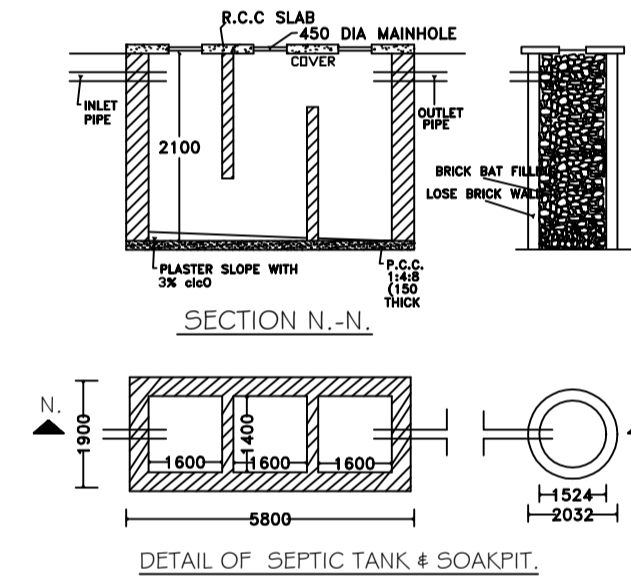
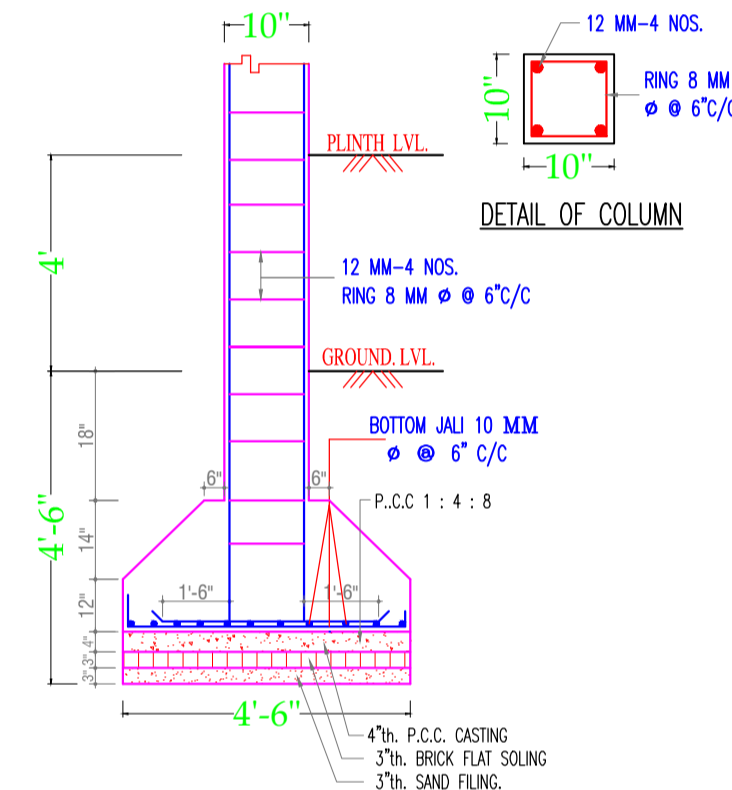

DETAIL OF SEPTIC TANK & SOAKPIT.

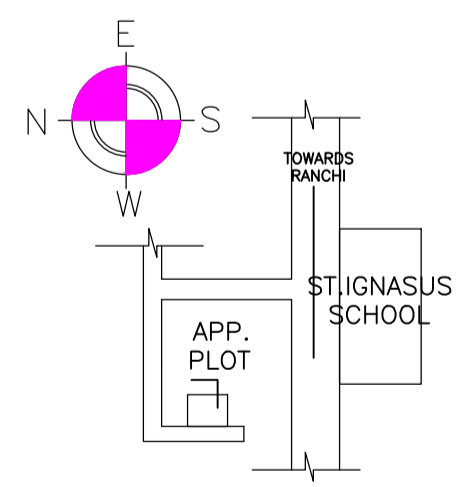

LOCATION
SCALE :- N.T.S

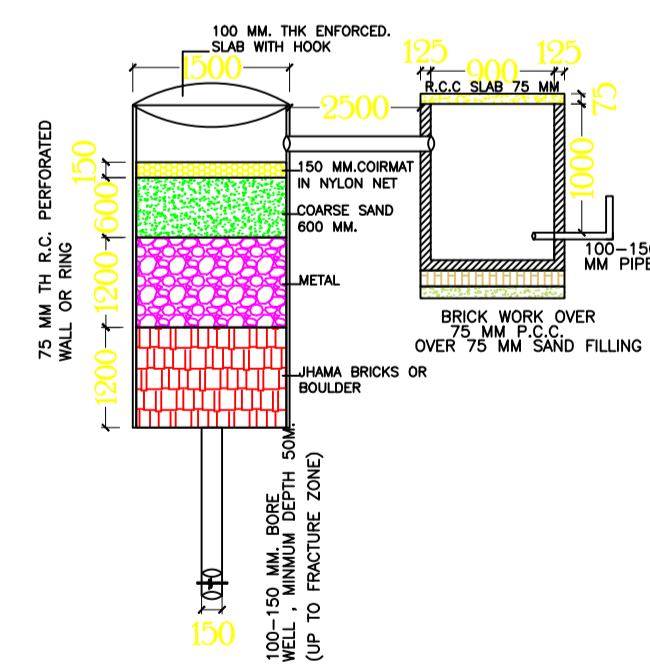

DETAIL OF GROUND WATER RECHARGING PIT WITH SLIT TANK
(SCALE 1:50)

LTP NAME AND SIGNATURE	STRUCTURAL ENG'S NAME AND SIGNATURE	BUILDER NAME AND SIGNATURE
DEEPAK DIWAN GUNPC/ARC/0003/2017		