

Building :A (RESIDENCIAL)

Floor Name	Total Built Up Area (Sq.mt)	Proposed FAR Area (Sq.mt.)		Total Consumed Additional FAR Area (Sq.mt.)	Tnmt (No.)
		Resi.	Total FAR Area (Sq.mt.)		
Ground Floor	108.40	108.40	108.40	108.40	01
First Floor	118.26	118.26	118.26	118.26	00
Terrace Floor	0.00	0.00	0.00	0.00	00
Total :	226.66	226.66	226.66	226.66	01
Total Number of Same Buildings	1				
Total :	226.66	226.66	226.66	226.66	01

AREA STATEMENT (GUMLA NAGAR PARISHAD)		VERSION NO.: 1.0.14	VERSION DATE: 11/07/2017
PROJECT DETAIL :			
Region: JHARKHAND URBAN LOCAL BODIES	Plot Use: Residential		
District: GUMLA PARISHAD	Plot SubUse: Residential Bldg/Apartment		
Authority: GUMLA NAGAR PARISHAD	PlotNearbyReligiousStructure: NA		
Inward No: GUNPC/BP/0001/M04/2017	Plot/SubPlot No: 598		
Application Type: General Proposal	North: Plot No. - 598		
Project Type: Building Permission	South: Plot No. - 598		
Nature of Development: New	East: Plot No. - 602		
Location of Development Area: Old Area	West: Road Width - 2.43		
AREA DETAILS :			
AREA OF PLOT (Minimum)	(A)		SQ.MT. 197.90
Deduction for NetPlot Area			20.44
Surrender Free of Cost			20.44
Total			20.44
NET AREA OF PLOT(Gross Plot Area - Deduction from Gross Plot area)	(A-Deductions)		177.46
Deduction for Balance Plot Area(from Gross Plot Area)			
Surrender Free of Cost			20.44
Common Plot			20.68
Total			41.13
BALANCE AREA OF PLOT(Net Plot Area - Recreational/Amenity space)	(A-Deductions)		156.77
PLOT AREA FOR COVERAGE(Net Plot Area)	(A-Deductions)		177.46
Plot Area for FAR (Net Plot Area + RoadWidening Area)	(A-Deductions)		197.90
COVERAGE CHECK			
Permissible Coverage area (70.00 %)			124.22
Proposed Coverage Area (61.09 %)			108.40
Total Prop. Coverage Area (61.09 %)			108.40
Balance coverage area (8.91 %)			15.82
FAR CHECK			
Perm. FAR Area (1.20)			237.48
Total Perm. FAR area			237.48
Residential FAR			226.67
Proposed FAR Area			226.67
Total Proposed FAR Area			226.67
Consumed FAR (Factor)			1.15
Balance FAR Area			10.81
BUILT UP AREA CHECK			
Total Proposed BuiltUp Area			226.66
ARCHITECT (Regd)		DEEPAK DIWAN	
ENGINEER (Regd)			
SUPERVISOR (Regd)			
OWNER (Regd)		RANJITA KUMARI GOPE	
DEVELOPMENT AUTHORITY		LOCAL BODY	

COLOR INDEX	
PLOT BOUNDARY	Black
ABUTTING ROAD	Green
PROPOSED CONSTRUCTION	Red
COMMON PLOT	Yellow
ROAD WIDENING AREA	Blue
EXISTING (To be retained)	Orange
EXISTING (To be demolished)	Light Blue

Buildingwise Floor FAR Details

Floor Name	Building Name		Total	
	Proposed Built Up Area (Sq.mt.)	Proposed FAR Area (Sq.mt.)	Total Proposed Built Up Area (Sq.mt.)	Total FAR Area (Sq.mt.)
Ground Floor	108.40	108.40	108.40	108.40
First Floor	118.26	118.26	118.26	118.26
Terrace Floor	0.00	0.00	0.00	0.00
Total :	226.66	226.66	226.66	226.66

Building USE/SUBUSE Details

Building Name	Building Use	Building SubUse	Building Structure
A (RESIDENCIAL)	Residential	Residential Bldg/Apartment	Non-Highrise

FAR & Tenement Details (Table 4c-1)

Building	No. of Same Bldg	Total Built Up Area (Sq.mt.)	Proposed FAR Area (Sq.mt.)		Total Consumed Additional FAR Area (Sq.mt.)	Tnmt (No.)
			Resi.	Total FAR Area (Sq.mt.)		
A (RESIDENCIAL)	1	226.66	226.66	226.66	226.66	01
Grand Total :	1	226.66	226.66	226.66	226.66	1.00

LTP NAME AND SIGNATURE	STRUCTURAL ENG'S NAME AND SIGNATURE	BUILDER NAME AND SIGNATURE
DEEPAK DIWAN GUNPC/ARC/0003/2017		

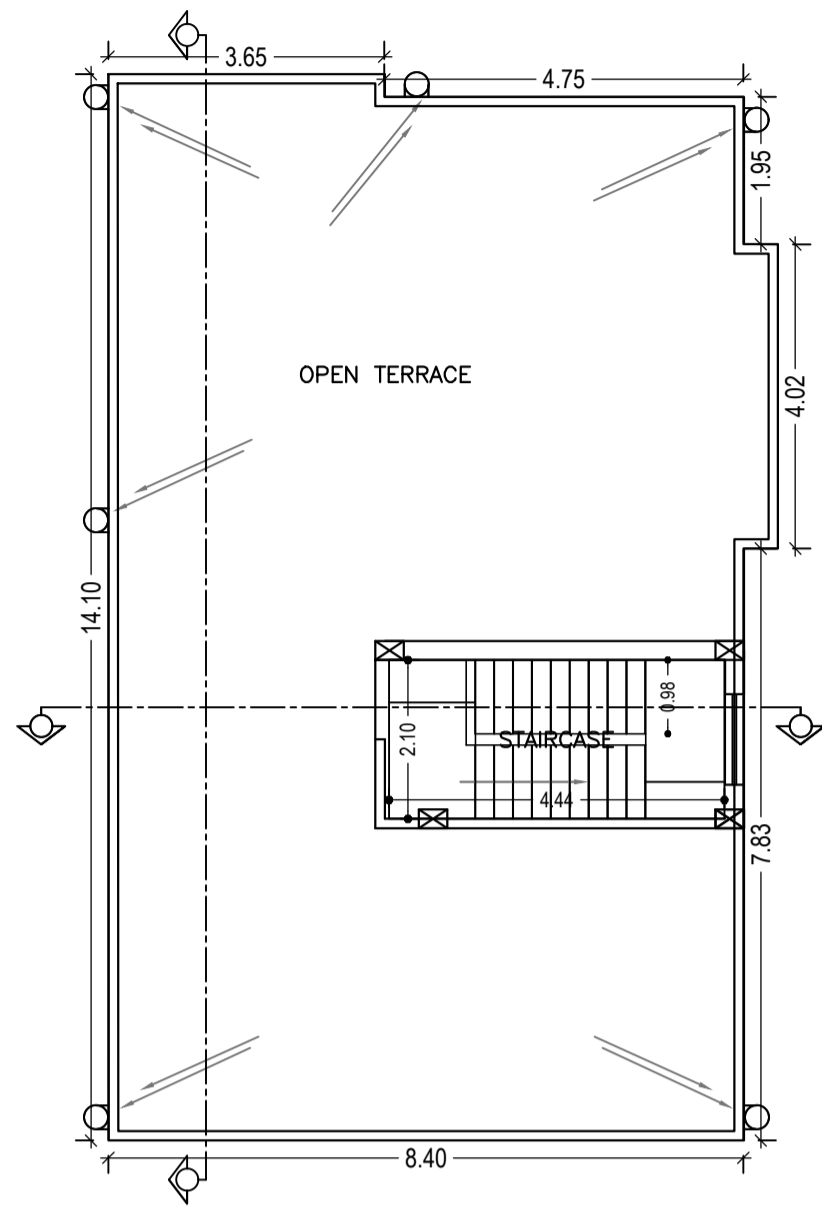
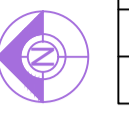

SCHEDULE OF DOOR:

BUILDING NAME	NAME	LENGTH	HEIGHT	NOS
A (RESIDENTIAL)	D	0.75	2.10	04
A (RESIDENTIAL)	D1	0.90	2.10	04
A (RESIDENTIAL)	D2	0.98	2.10	04
A (RESIDENTIAL)	D3	1.20	2.10	02

SCHEDULE OF WINDOW/VENTILATION:

BUILDING NAME	NAME	LENGTH	HEIGHT	NOS
A (RESIDENTIAL)	V	0.60	1.20	02
A (RESIDENTIAL)	W	1.20	1.20	09
A (RESIDENTIAL)	W1	1.35	1.20	06

TERRACE FLOOR PLAN (SCALE 1:100)

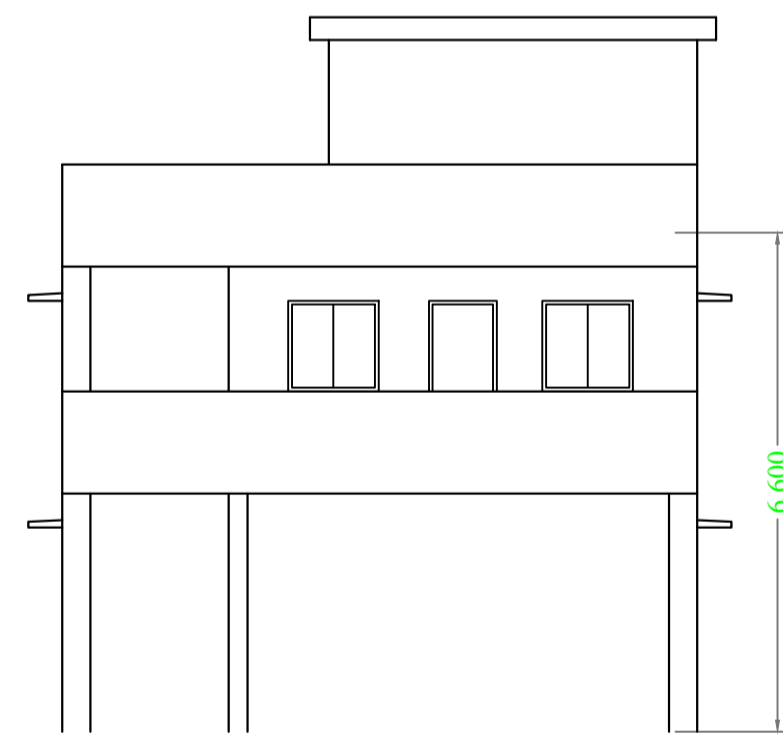

FRONT ELEVATION (SCALE 1:100)

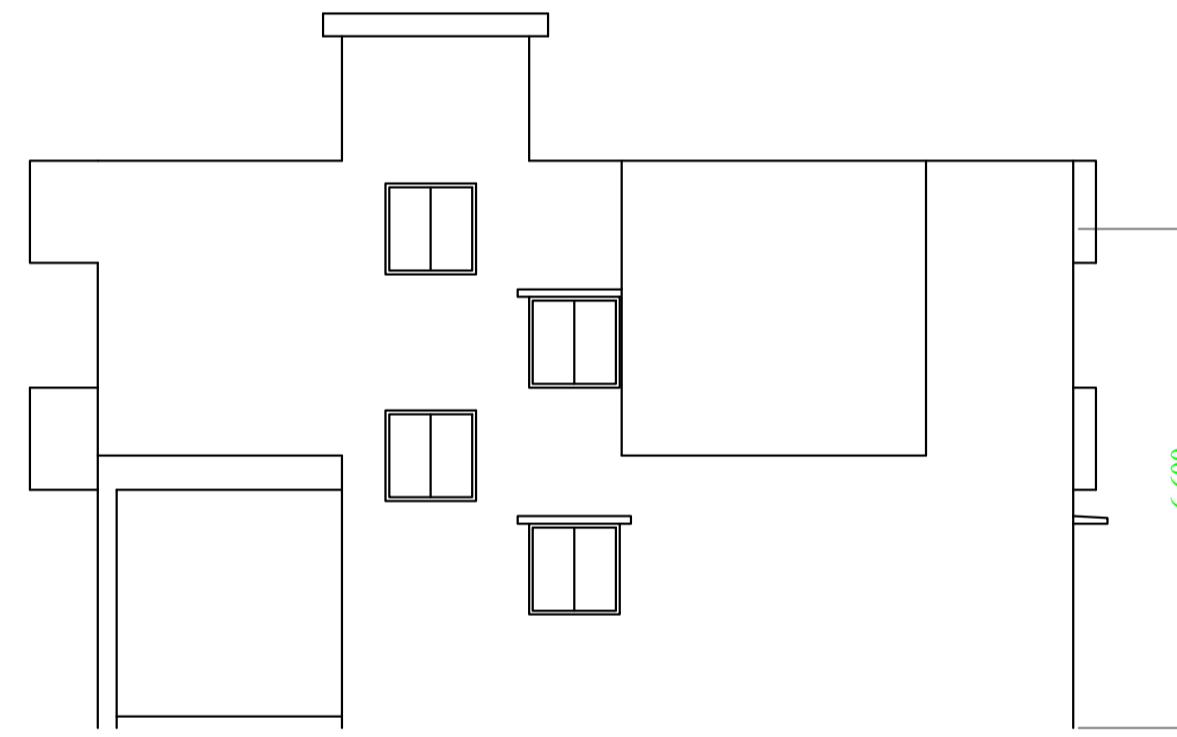

SIDE ELEVATION (SCALE 1:100)

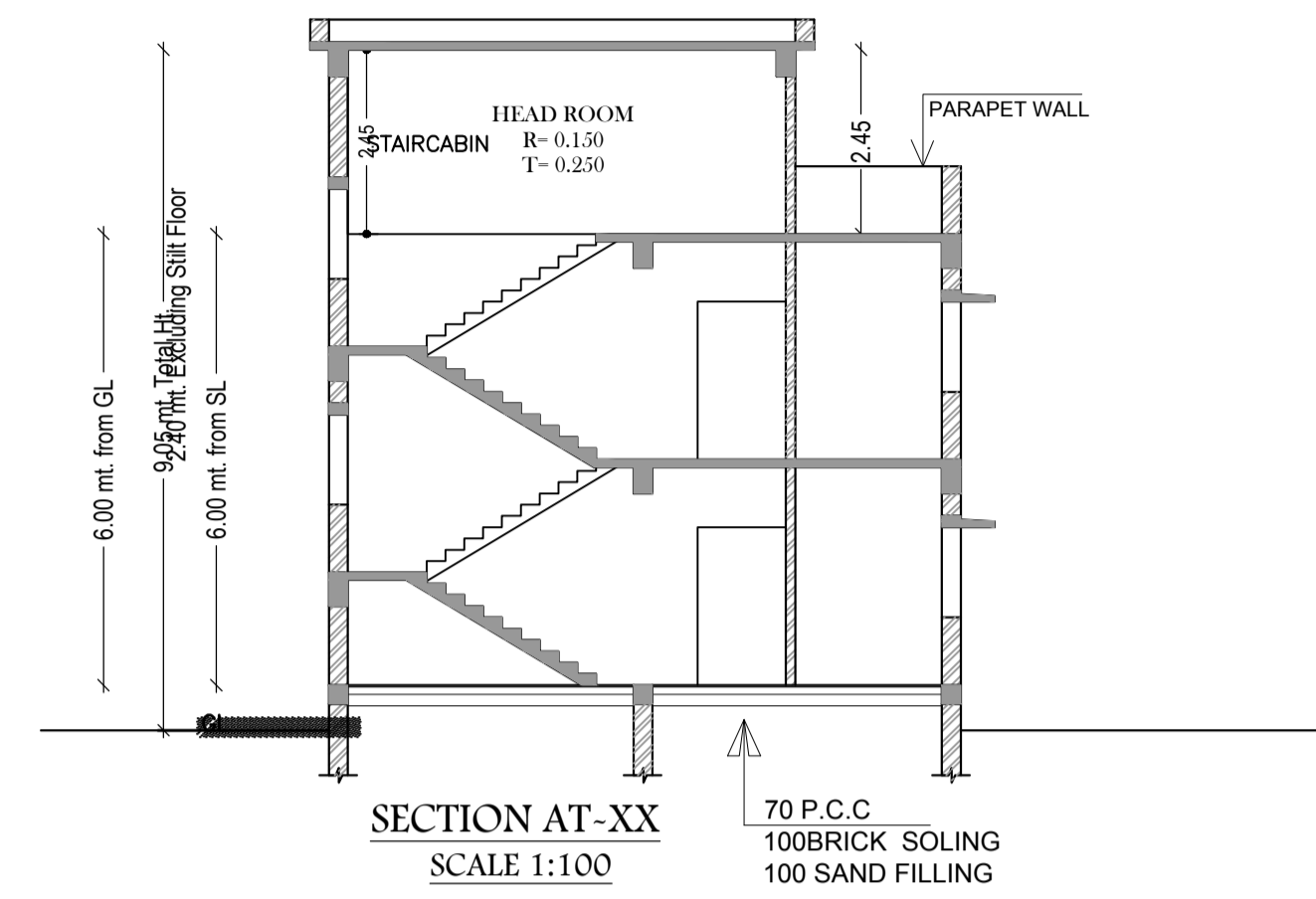

SECTION AT-XX (SCALE 1:100)

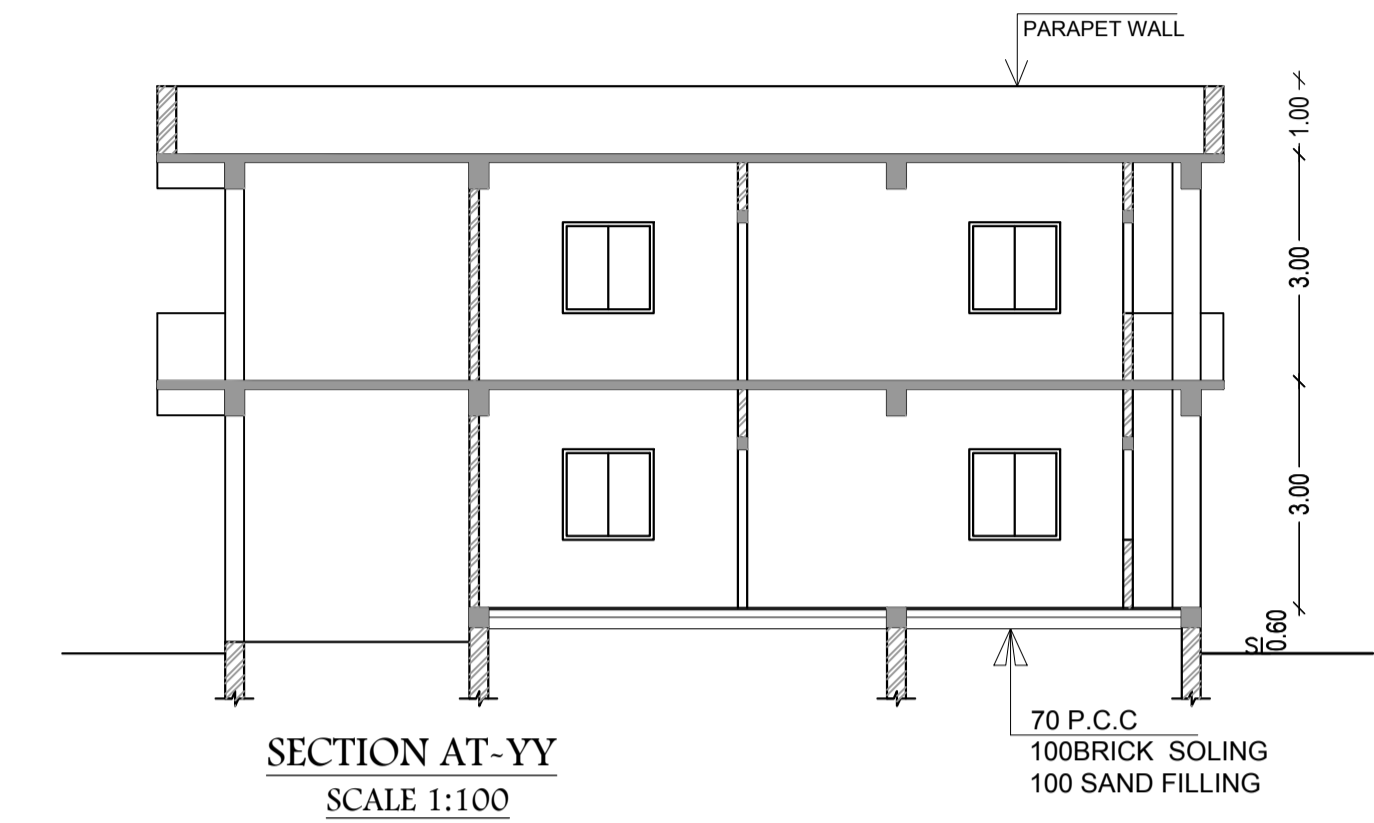

SECTION AT-YY (SCALE 1:100)

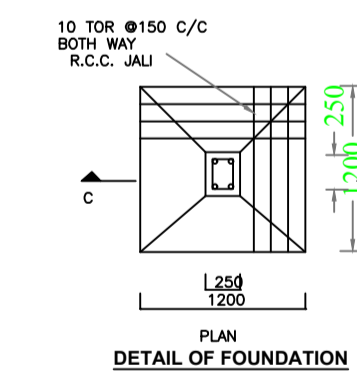
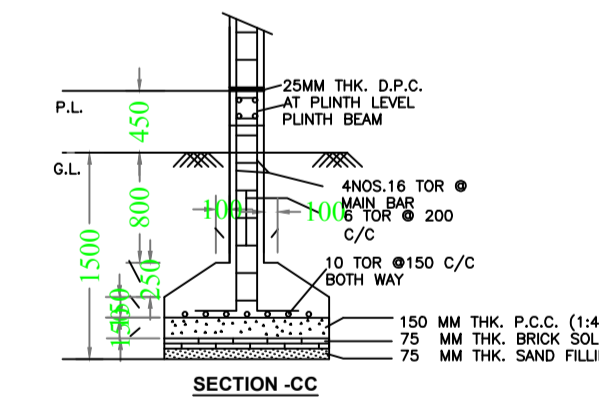
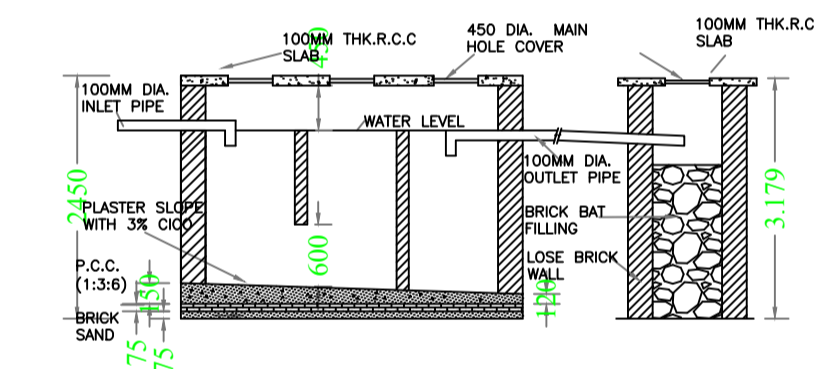
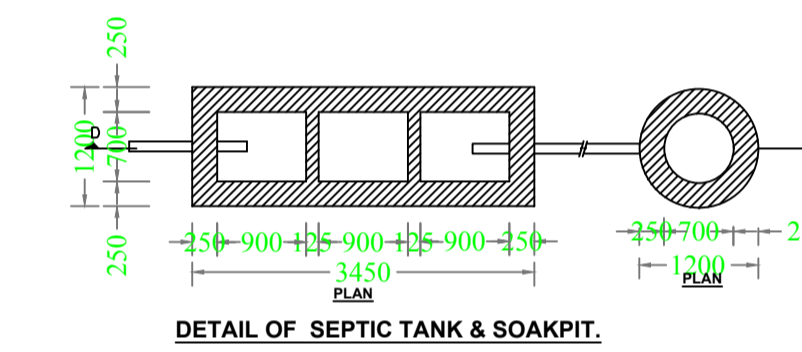
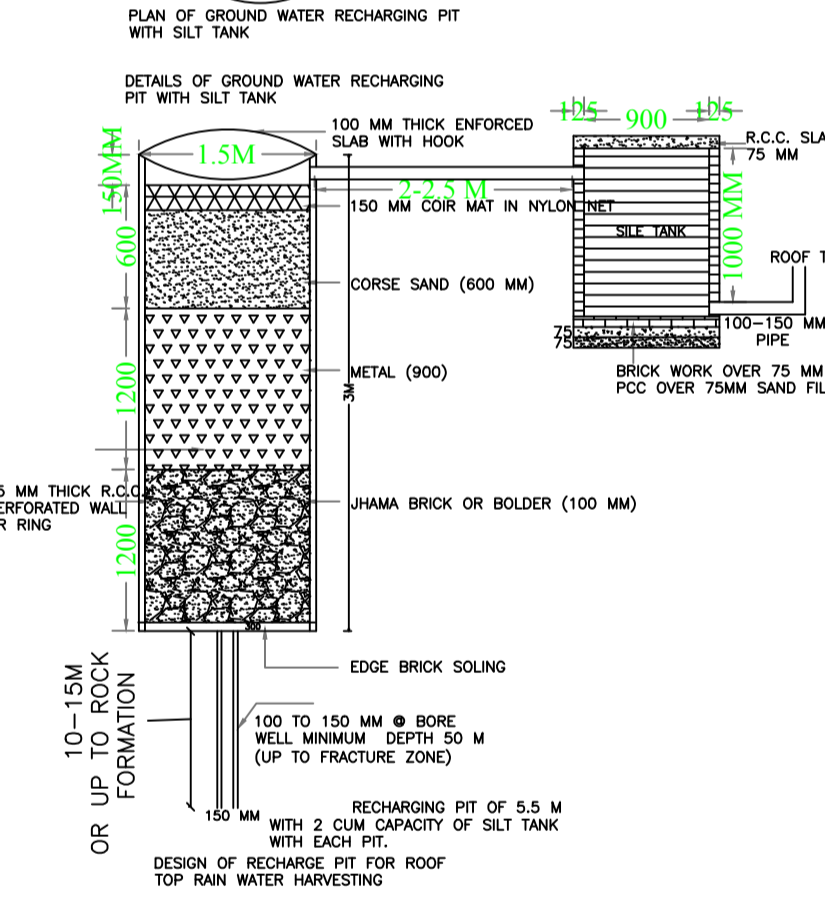
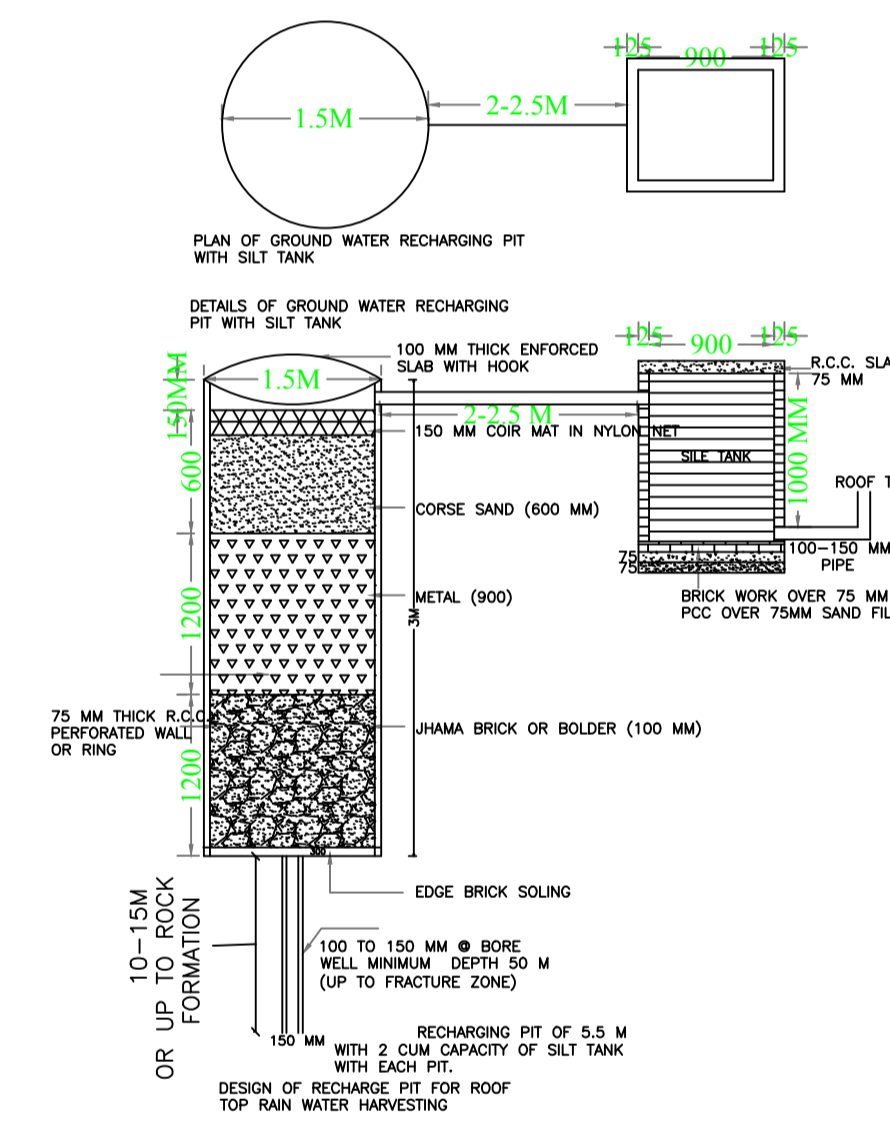

LTP NAME AND SIGNATURE	STRUCTURAL ENG'S NAME AND SIGNATURE	BUILDER NAME AND SIGNATURE
DEEPAK DIWAN GUNPC/ARC/0003/2017		