

AREA STATEMENT GUMLA NAGAR PARISHAD		VERSION NO.: 1.0.22
PROJECT DETAIL:		VERSION DATE: 28/09/2017
Region: JHARKHAND URBAN LOCAL BODIES	Plot Use: Residential	
District: GUMLA	Plot SubUse: Residential Bldg/Apartment	
Authority: GUMLA NAGAR PARISHAD	Plot/Nearby/Religious/Structure: NA	
Inward No: GUNPC/BP/0014/W/19/2018	Plot/SubPlot No: 981	
Application Type: General Proposal	North: -	
Project Type: Building Permission	South: -	
Nature of Development: New	East: -	
Location of Development Area: Old Area	West: -	
AREA DETAILS:		SQ. MT.
AREA OF PLOT (Minimum)	(A)	341.86
Deduction for NetPlot Area		
Surrender Free of Cost		19.93
Total		19.93
NET AREA OF PLOT(Gross Plot Area - Deduction from Gross Plot area)	(A-Deductions)	321.94
Deduction for Balance Plot Area(from Gross Plot Area)		
Surrender Free of Cost		19.93
Common Plot		34.01
Total		53.94
BALANCE AREA OF PLOT(Net Plot Area - Recreational/Amenity space)	(A-Deductions)	287.92
PLOT AREA FOR COVERAGE(Net Plot Area)	(A-Deductions)	321.94
Plot Area for FAR (Net Plot Area + RoadWidening Area)	(A-Deductions)	341.86
COVERAGE CHECK		
Permissible Coverage area ( 60.00 % )		193.16
Proposed Coverage Area ( 58.74 % )		189.12
Total Prop. Coverage Area ( 58.74 % )		189.12
Balance coverage area ( 1.25 % )		4.04
FAR CHECK		
Perm. FAR Area ( 1.80 )		615.35
Total Perm. FAR area		615.35
Residential FAR		384.46
Proposed FAR Area		395.77
Total Proposed FAR Area		395.77
Consumed FAR (Factor)		1.16
Balance FAR Area		219.58
BUILT UP AREA CHECK		
Total Proposed BuiltUp Area		581.57
ARCHITECT (Regd)	DEEPAK DIWAN	
ENGINEER (Regd)		
SUPERVISOR (Regd)		
OWNER (Regd)	SHEO KUMAR PRASAD	
DEVELOPMENT AUTHORITY	LOCAL BODY	

Building :A (SRI SHEO KUMAR PRASAD)

Floor Name	Total Built Up Area (Sq.mt.)	Deductions (Area in Sq.mt.)		Proposed FAR Area (Sq.mt.)	Add Area In FAR (Sq.mt.)	Total FAR Area (Sq.mt.)	Total Consumed Additional FAR Area (Sq.mt.)	Tnmt (No.)
		Lift	Parking					
Ground Floor	189.13	0.00	177.82	0.00	7.32	11.31	11.31	00
First Floor	196.22	3.99	0.00	192.23	0.00	192.23	192.23	01
Second Floor	196.22	3.99	0.00	192.23	0.00	192.23	192.23	01
Terrace Floor	0.00	0.00	0.00	0.00	0.00	0.00	0.00	00
<b>Total :</b>	<b>581.57</b>	<b>7.98</b>	<b>177.82</b>	<b>384.46</b>	<b>7.32</b>	<b>395.77</b>	<b>395.77</b>	<b>02</b>
Total Number of Same Buildings :	1							
<b>Total :</b>	<b>581.57</b>	<b>7.98</b>	<b>177.82</b>	<b>384.46</b>	<b>7.32</b>	<b>395.77</b>	<b>395.77</b>	<b>02</b>

SCHEDULE OF DOOR:

BUILDING NAME	NAME	LENGTH	HEIGHT	NOS
A (SRI SHEO KUMAR PRASAD)	D2	0.76	2.13	16
A (SRI SHEO KUMAR PRASAD)	D3	0.76	2.13	04
A (SRI SHEO KUMAR PRASAD)	D1	0.90	2.13	12
A (SRI SHEO KUMAR PRASAD)	D	1.05	2.13	04

SCHEDULE OF WINDOW/VENTILATION:

BUILDING NAME	NAME	LENGTH	HEIGHT	NOS
A (SRI SHEO KUMAR PRASAD)	V	0.76	2.50	08
A (SRI SHEO KUMAR PRASAD)	W2	1.50	2.50	06
A (SRI SHEO KUMAR PRASAD)	W1	2.00	2.50	04
A (SRI SHEO KUMAR PRASAD)	W	2.00	2.50	12

UnitBUA Table for Building :A (SRI SHEO KUMAR PRASAD)

FLOOR	Name	UnitBUA Type	UnitBUA Area	Carpet Area	No. of Rooms	No. of Tenement
TYPICAL - 1 & 2 FLOOR PLAN	SPLIT SRI SHEO KUMAR PRASAD	FLAT	236.41	225.09	9	2
	SPLIT SRI SHEO KUMAR PRASAD	FLAT	0.00	0.00	9	9
<b>Total:</b>			<b>472.82</b>	<b>450.18</b>	<b>36</b>	<b>2</b>

COLOR INDEX	
PLOT BOUNDARY	Black
ABUTTING ROAD	Green
PROPOSED CONSTRUCTION	Red
COMMON PLOT	Yellow
ROAD WIDENING AREA	Blue
EXISTING (To be retained)	Orange
EXISTING (To be demolished)	Grey

Building USE/SUBUSE Details

Building Name	Building Use	Building SubUse	Building Structure
A (SRI SHEO KUMAR PRASAD)	Residential	Residential Bldg/Apartment	Non-Highrise

Buildingwise Floor FAR Details

Floor Name	Building Name		Total	
	Proposed Built Up Area (Sq.mt.)	Proposed FAR Area (Sq.mt.)	Total Proposed Built Up Area (Sq.mt.)	Total FAR Area (Sq.mt.)
Ground Floor	189.13	11.31	189.13	11.31
First Floor	196.22	192.23	196.22	192.23
Second Floor	196.22	192.23	196.22	192.23
Terrace Floor	0.00	0.00	0.00	0.00
<b>Total :</b>	<b>581.57</b>	<b>395.77</b>	<b>581.57</b>	<b>395.77</b>

FAR & Tenement Details (Table 4c-1)

Building	No. of Same Bldg	Total Built Up Area (Sq.mt.)	Deductions (Area in Sq.mt.)		Proposed FAR Area (Sq.mt.)	Add Area In FAR (Sq.mt.)	Total FAR Area (Sq.mt.)	Total Consumed Additional FAR Area (Sq.mt.)	Tnmt (No.)
			Lift	Parking					
A (SRI SHEO KUMAR PRASAD)	1	581.57	7.98	177.82	384.46	7.32	395.77	395.77	02
<b>Total</b>	<b>1</b>	<b>581.57</b>	<b>7.98</b>	<b>177.82</b>	<b>384.46</b>	<b>7.32</b>	<b>395.77</b>	<b>395.77</b>	<b>02</b>

Required Parking(Table 7a)

Building Name	Type	SubUse	Area (Sq.mt.)	Units		Car		Visitors Car		TwoWheeler	
				Reqd.	Prop.	Reqd./Unit	Reqd.	Prop.	Reqd./Unit	Reqd.	Prop.
A (SRI SHEO KUMAR PRASAD)	Residential	Residential Bldg/Apartment	> 0	1	2.00	1	2	-	-	-	-
A (SRI SHEO KUMAR PRASAD)			> 0	1	2.00	-	-	-	-	1	2
A (SRI SHEO KUMAR PRASAD)			> 0	1	2.00	-	-	-	1	1	-
<b>Total :</b>							2	2	1	1	2

Parking Check (Table 7b)

Vehicle Type	No.	Reqd.		No.	Prop.	
		Area	Area		Area	Area
Car	2	25.00	2	25.00	2	25.00
Visitor's Car Parking	1	12.50	1	12.50	1	12.50
TwoWheeler	2	4.00	6	12.00	2	12.00
Other Parking	-	-	-	-	-	128.32
<b>Total</b>		41.50	6	49.50	5	177.82

LTP NAME AND SIGNATURE	STRUCTURAL ENG'S NAME AND SIGNATURE	BUILDER NAME AND SIGNATURE
DEEPAK DIWAN GUNPC/ARC/0003/2017		

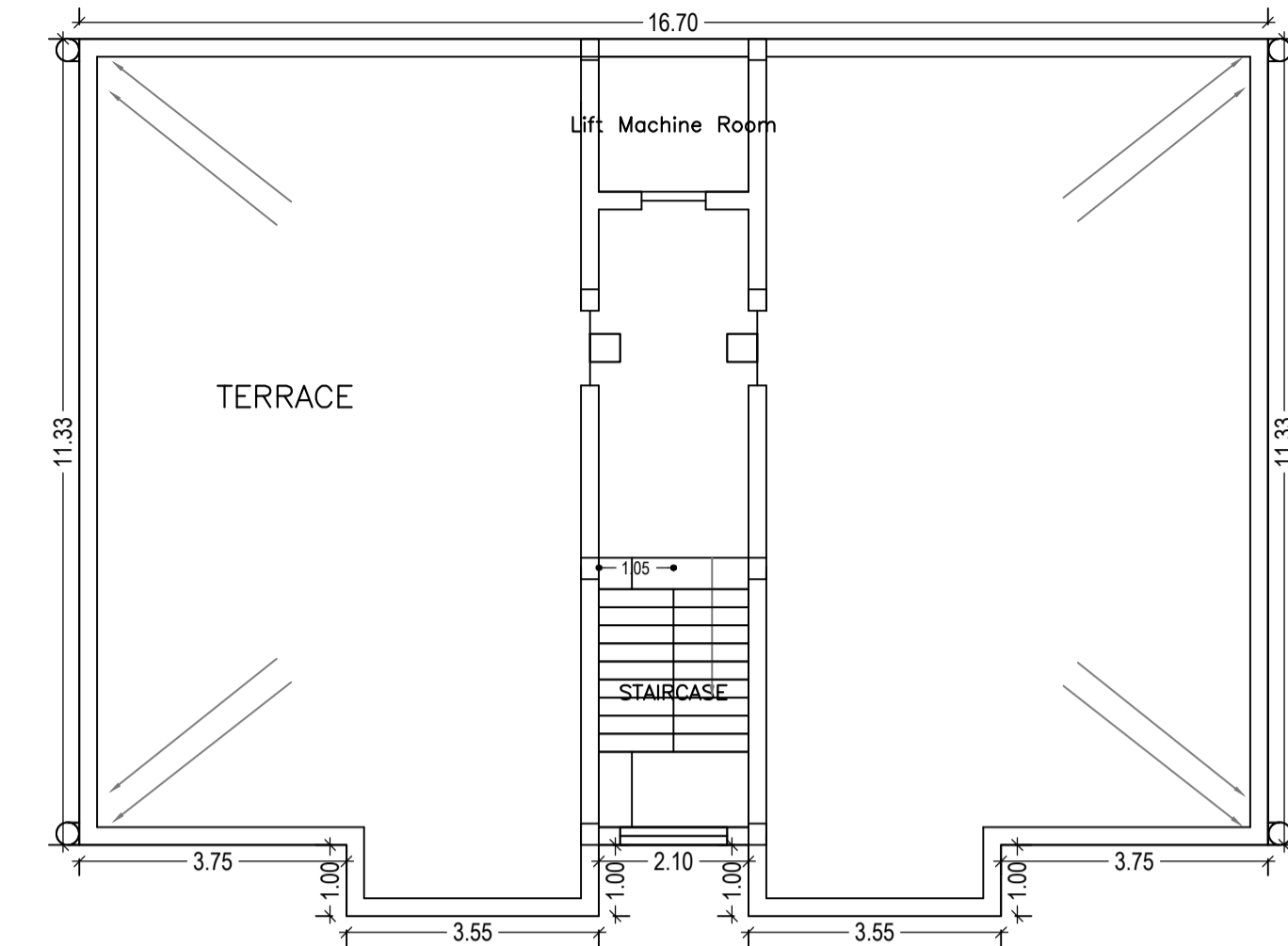
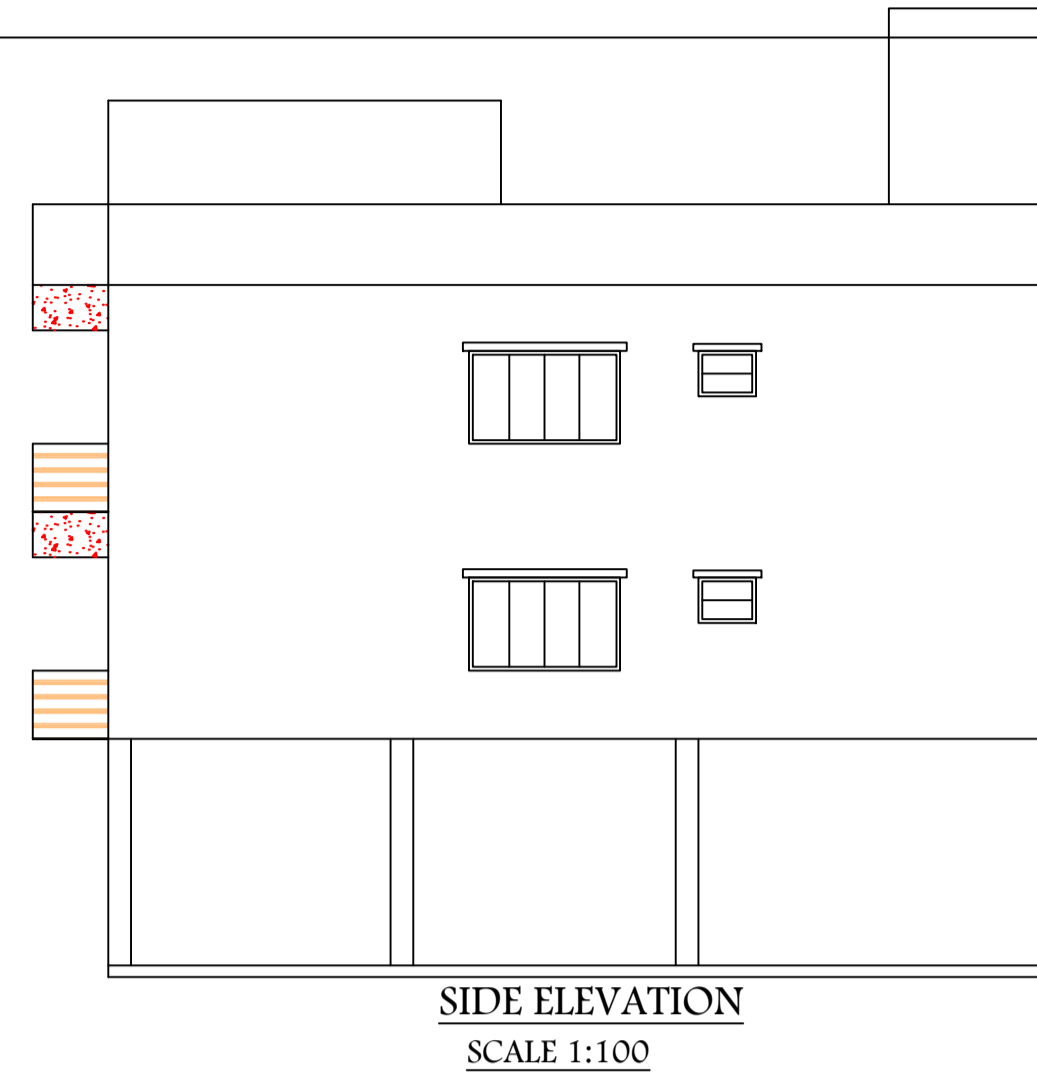
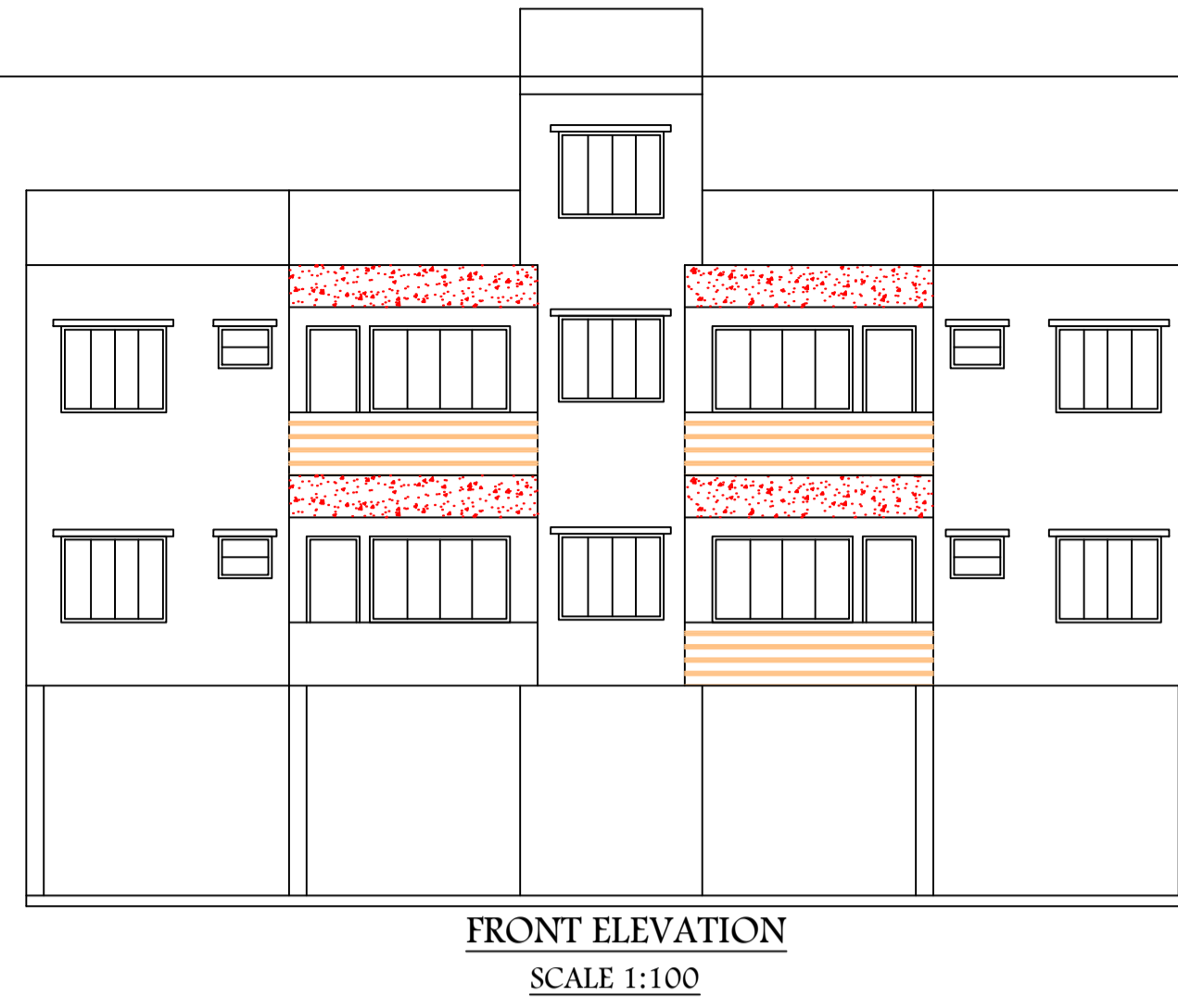
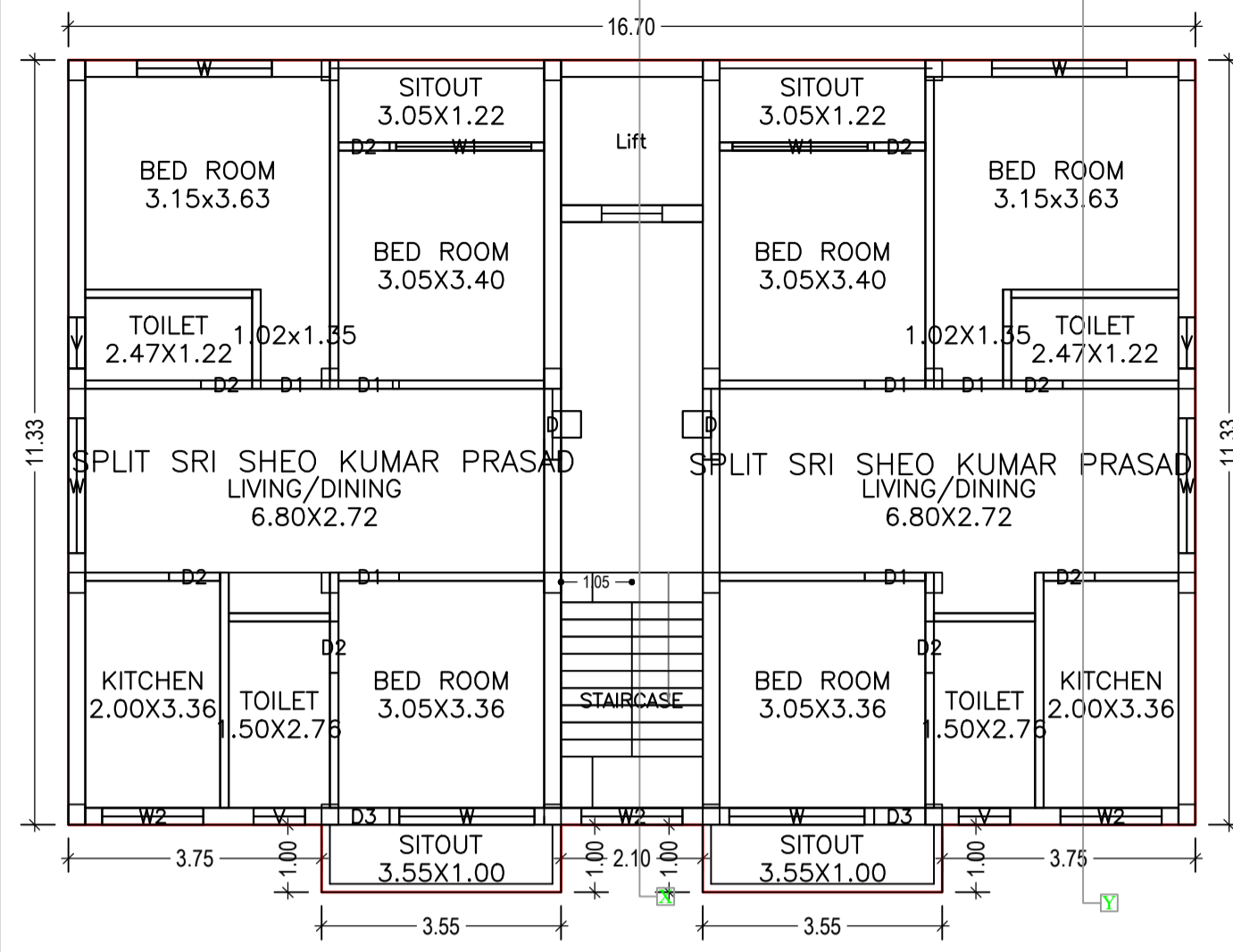

TYPICAL - 1 & 2 FLOOR PLAN  
(Proposed)  
(SCALE 1:100)

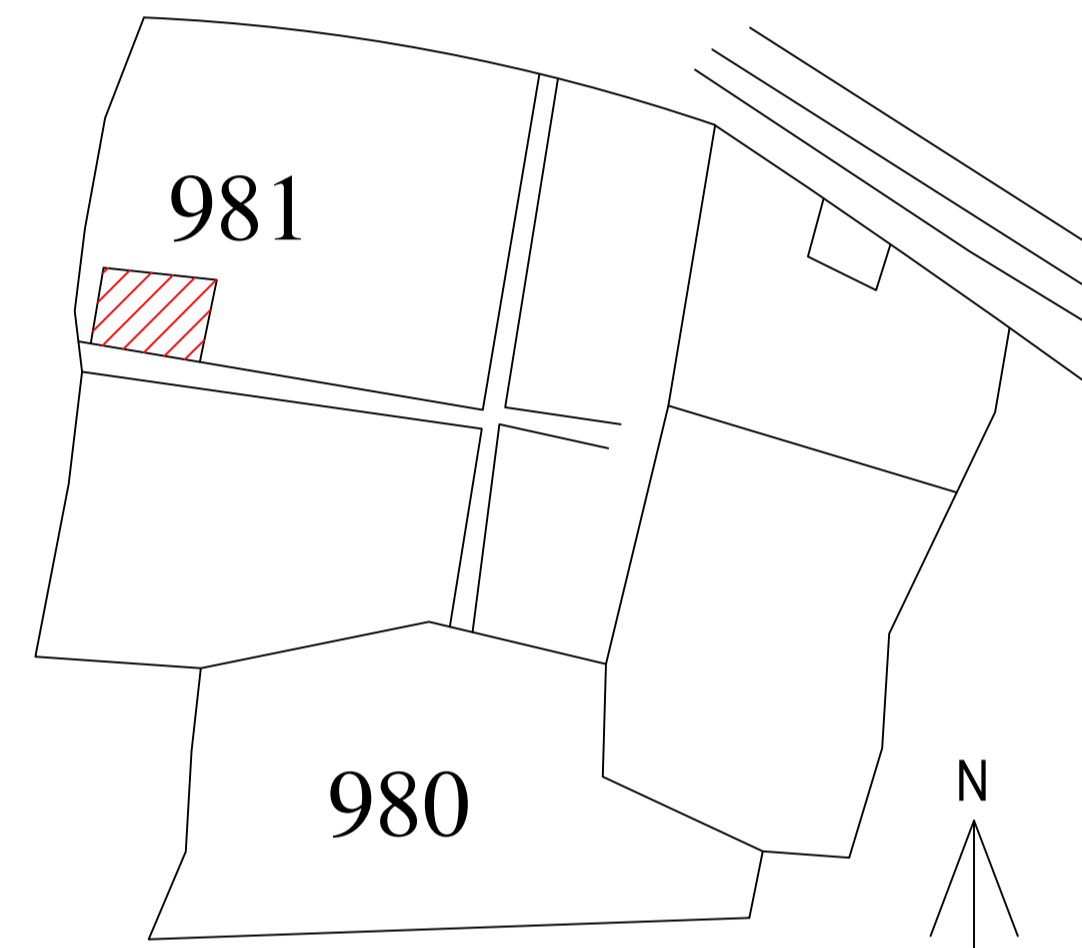
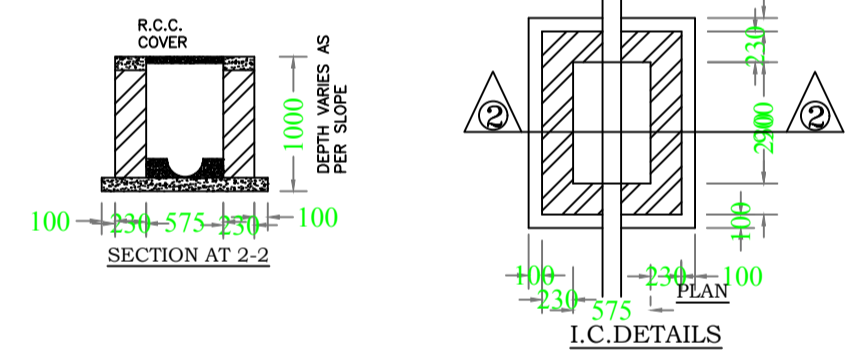
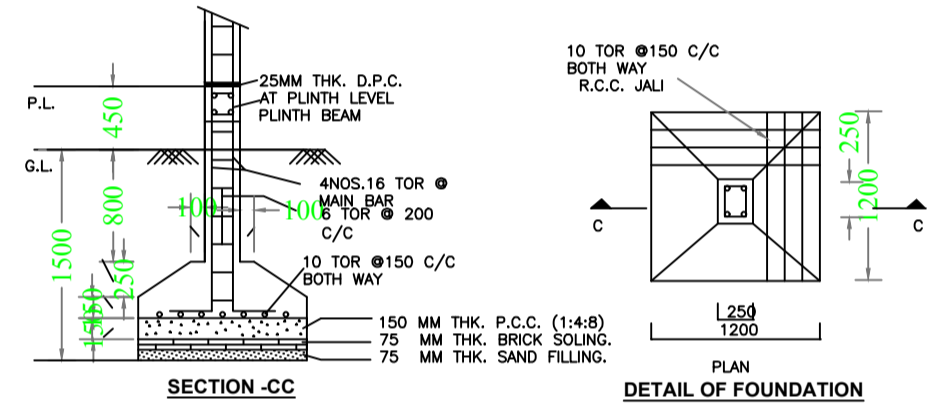

VILLAGE MAP  
N.T.S.

TERRACE FLOOR PLAN  
(SCALE 1:100)

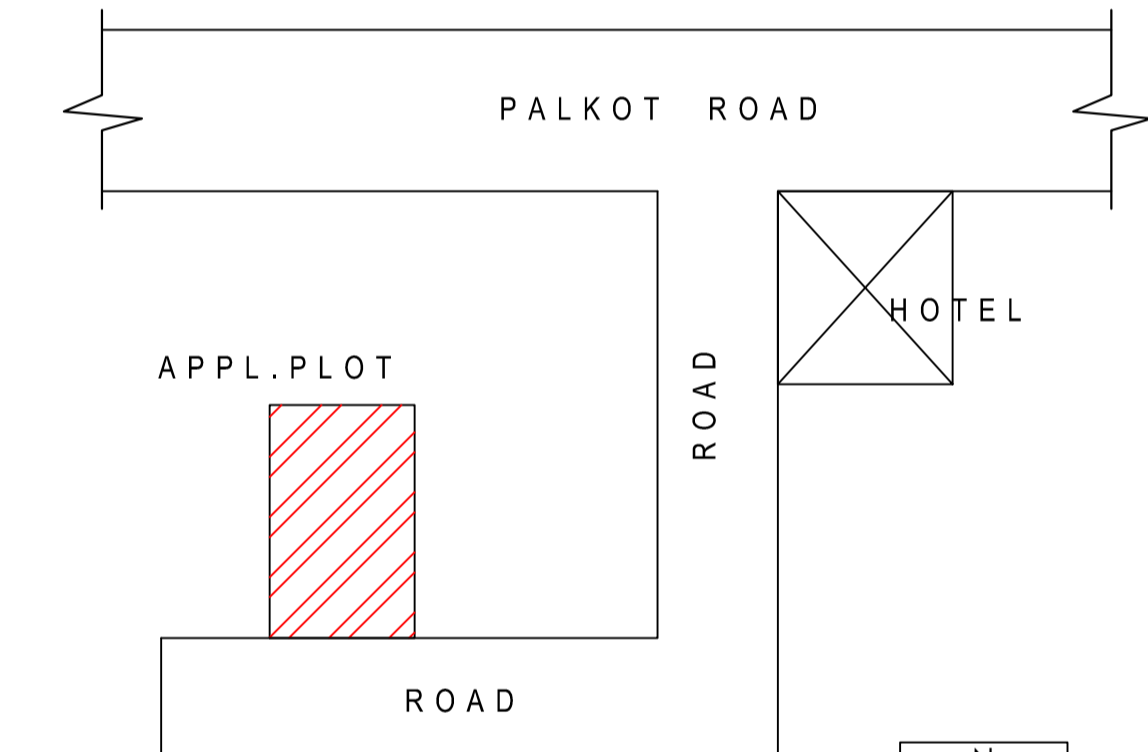

LOCATION PLAN  
N.T.S.

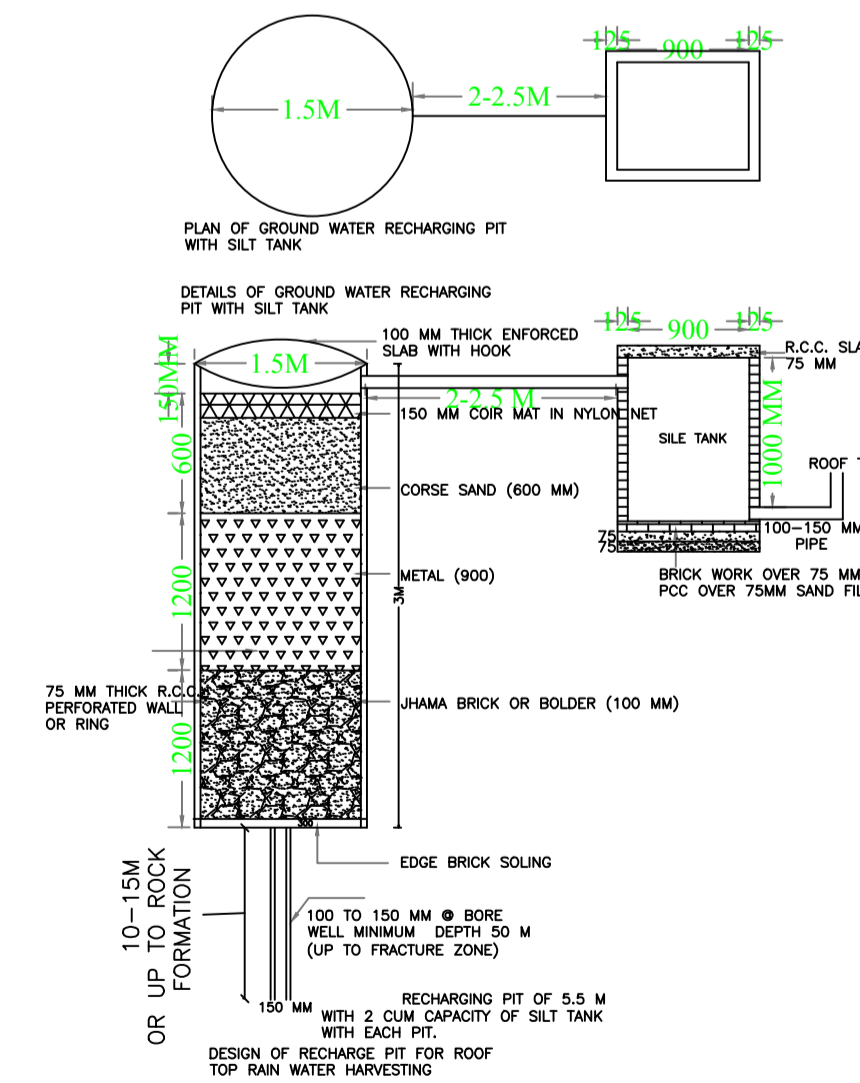
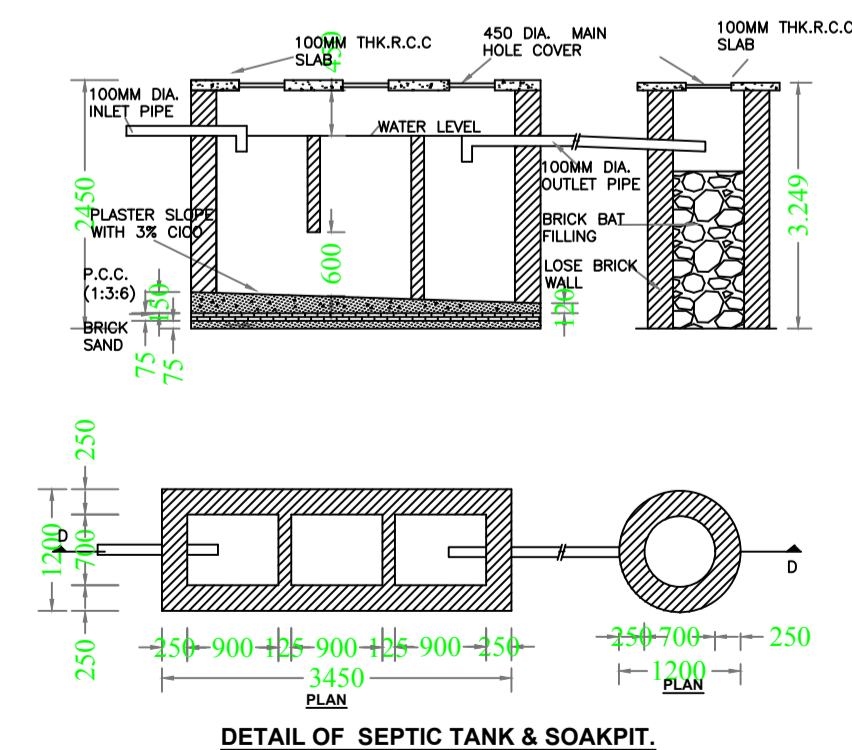

LTP NAME AND SIGNATURE	STRUCTURAL ENG'S NAME AND SIGNATURE	BUILDER NAME AND SIGNATURE
DEEPAK DIWAN GUNPC/ARC/0003/2017		