

Proposal Basic Information	
Proposal File No.	GUNPC/BP/0015/W14/2019
Owner Name	SMT SHANTI TOPPO
Khata No	34
Plot No	953
Village Name	Karam Toli
Use	Residential
SubUse	Bungalow/ Dwelling / Non Apartment

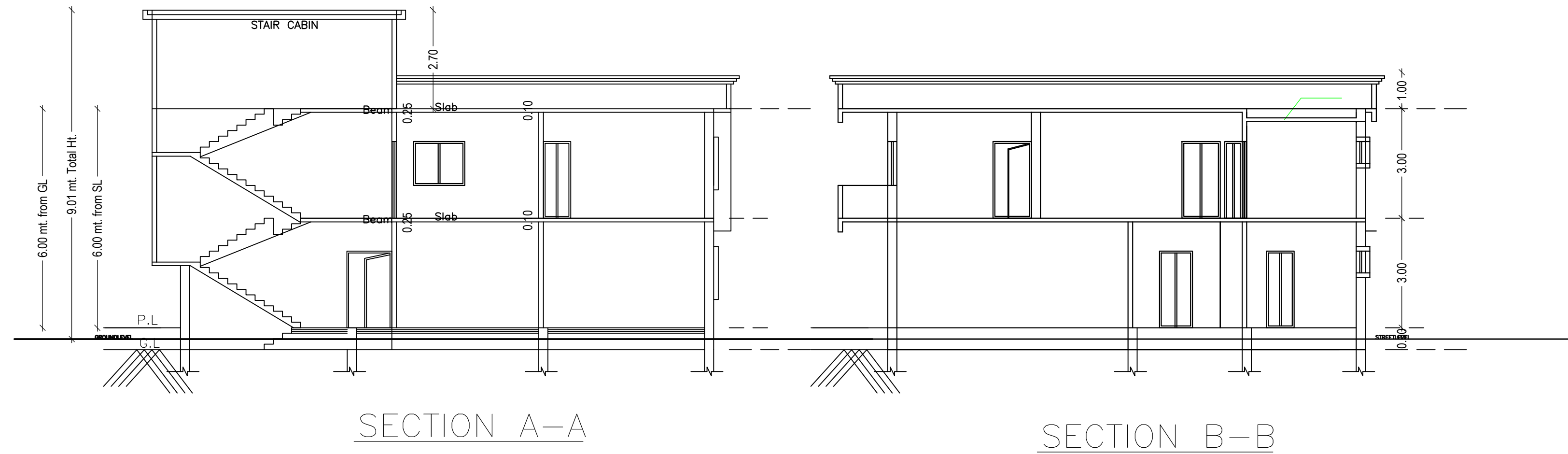
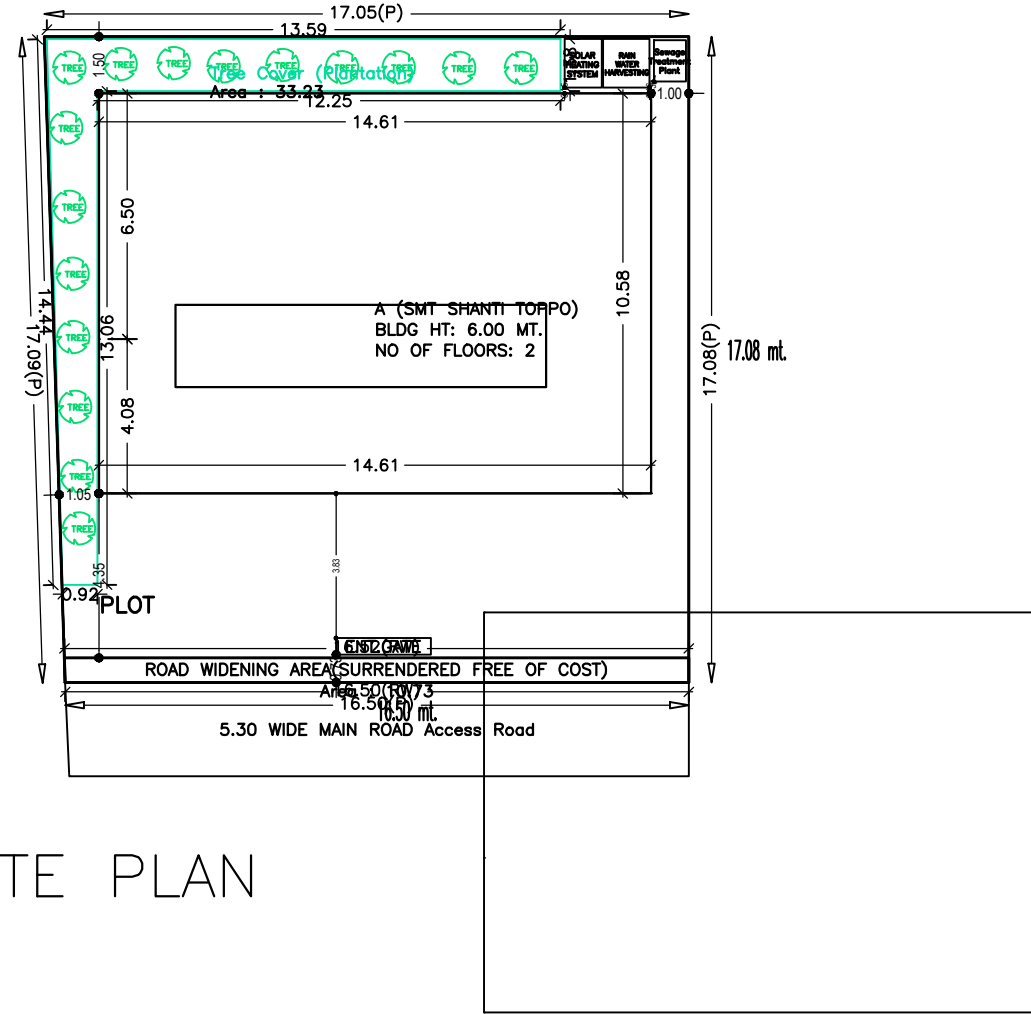

SITE PLAN

SECTION A-A

SECTION B-B

SCHEDULE OF DOOR:

BUILDING NAME	NAME	LENGTH	HEIGHT	NOS
A (SMT SHANTI TOPPO)	D2	0.75	2.13	08
A (SMT SHANTI TOPPO)	D1	0.95	2.13	09
A (SMT SHANTI TOPPO)	D	1.07	2.13	02

SCHEDULE OF WINDOW/VENTILATION:

BUILDING NAME	NAME	LENGTH	HEIGHT	NOS
A (SMT SHANTI TOPPO)	V	0.60	2.70	03
A (SMT SHANTI TOPPO)	W2	1.00	2.70	03
A (SMT SHANTI TOPPO)	W1	1.20	2.70	07
A (SMT SHANTI TOPPO)	W	1.33	2.70	01
A (SMT SHANTI TOPPO)	W	1.80	2.70	06
A (SMT SHANTI TOPPO)	W0	2.50	2.70	02

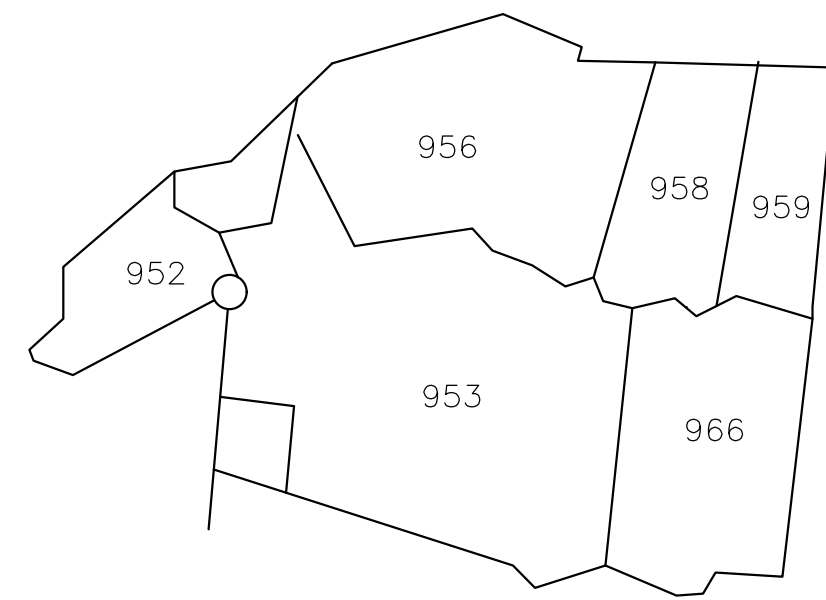

VILLAGE MAP

UnitBUA Table for Building :A (SMT SHANTI TOPPO)

FLOOR	Name	UnitBUA Type	UnitBUA Area	Carpet Area	No. of Rooms	No. of Tenement
GROUND FLOOR PLAN	SPLIT A	FLAT	237.15	236.81	7	1
FIRST FLOOR PLAN	SPLIT A	FLAT	0.00	0.00	12	0
Total:	-	-	237.15	236.81	19	1

COLOR INDEX	
PLOT BOUNDARY	[Red Line]
ABUTTING ROAD	[Green Line]
PROPOSED CONSTRUCTION	[Blue Line]
COMMON PLOT	[Yellow Line]
ROAD WIDENING AREA	[Orange Line]
EXISTING (To be retained)	[Light Blue Line]
EXISTING (To be demolished)	[Light Yellow Line]

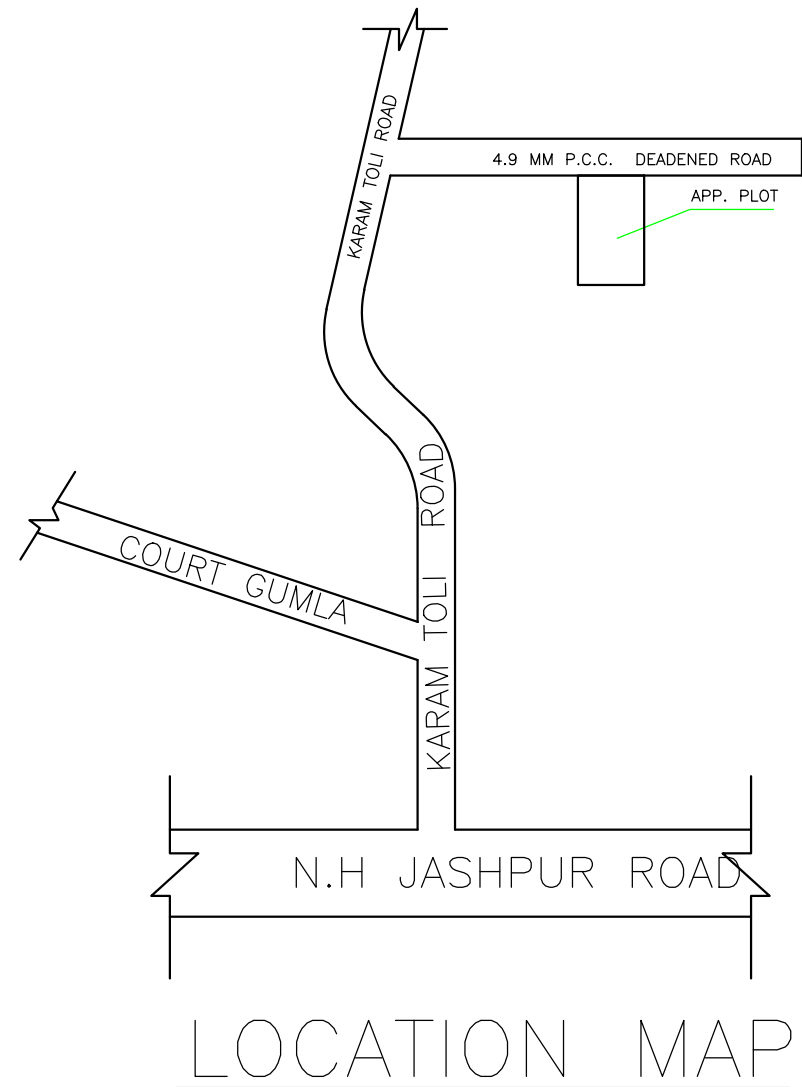

LOCATION MAP

FAR & Tenement Details (Table 4c-1)

Building	No. of Same Bldg	Total Built Up Area (Sq.mt.)	Deductions (Area in Sq.mt.) Parking	Proposed FAR Area (Sq.mt.) Resi.	Total FAR Area (Sq.mt.)	Total Consumed Additional FAR Area (Sq.mt.)	Tnmt (No.)
A (SMT SHANTI TOPPO)	1	332.99	44.93	288.06	288.06	288.06	01
Grand Total :	1	332.99	44.93	288.06	288.06	288.06	01

Buildingwise Floor FAR Details

Floor Name	Building Name A (SMT SHANTI TOPPO)		Total	
	Proposed Built Up Area (Sq.mt.)	Proposed FAR Area (Sq.mt.)	Total Proposed Built Up Area (Sq.mt.)	Total FAR Area (Sq.mt.)
Ground Floor	154.62	109.69	154.62	109.69
First Floor	178.37	178.37	178.37	178.37
Terrace Floor	0.00	0.00	0.00	0.00
Total :	332.99	288.06	332.99	288.06

Building USE/SUBUSE Details

Building Name	Building Use	Building SubUse	Building Structure
A (SMT SHANTI TOPPO)	Residential	Bungalow/ Dwelling / Non Apartment	Non-Highrise

Building :A (SMT SHANTI TOPPO)

Floor Name	Total Built Up Area (Sq.mt.)	Deductions (Area in Sq.mt.) Parking	Proposed FAR Area (Sq.mt.) Resi.	Total FAR Area (Sq.mt.)	Total Consumed Additional FAR Area (Sq.mt.)	Tnmt (No.)
Ground Floor	154.62	44.93	109.69	109.69	109.69	01
First Floor	178.37	0.00	178.37	178.37	178.37	00
Terrace Floor	0.00	0.00	0.00	0.00	0.00	00
Total :	332.99	44.93	288.06	288.06	288.06	01
Total Number of Same Buildings :	1					
Total :	332.99	44.93	288.06	288.06	288.06	01

AREA STATEMENT GUMLA NAGAR PARISHAD		VERSION NO. : 1.0.42
PROJECT DETAIL:		VERSION DATE: 29/04/2019
Region: JHARKHAND URBAN LOCAL BODIES	Plot Use: Residential	
District: GUMLA	Plot SubUse: Bungalow/ Dwelling / Non Apartment	
Authority: GUMLA NAGAR PARISHAD	PlotNearby/ReligiousStructure: NA	
Inward_No: GUNPC/BP/0015/W14/2019	Plot/SubPlot No: 953	
Application Type: General Proposal	North: Plot No. - TARH NIZ	
Project Type: Building Permission	South: Plot No. - TARH NARAYAN ORAON	
Nature of Development: New	East: Road Width - TARH MANGRA ORAON	
Location of Development Area: Old Area	West: Road Width - 5.20 MTR WIDE	
AREA OF PLOT (Minimum)	(A)	286.58
Deduction for NetPlot Area	Surrender Free of Cost	10.73
NET AREA OF PLOT(Gross Plot Area - Deduction from Gross Plot area)	(A-Deductions)	275.84
Deduction for Balance Plot Area(from Gross Plot Area)	Surrender Free of Cost	10.73
Common Plot	Total	43.97
BALANCE AREA OF PLOT(Net Plot Area - Recreational/Amenity space)	(A-Deductions)	242.61
PLOT AREA FOR COVERAGE(Net Plot Area)	(A-Deductions)	275.84
Plot Area for FAR (Net Plot Area + RoadWidening Area)	(A-Deductions)	286.58
COVERAGE CHECK	Permissible Coverage area (60.00 %)	165.50
Proposed Coverage Area (56.05 %)	Total Prop. Coverage Area (56.05 %)	154.61
Balance coverage area (3.95 %)		10.89
FAR CHECK	Perm. FAR Area (1.80)	515.84
Total Perm. FAR area	Residential FAR	288.06
Proposed FAR Area	Total Proposed FAR Area	288.06
Consumed FAR (Factor)		1.01
Balance FAR Area		227.78
BUILT UP AREA CHECK	Total Proposed BuiltUp Area	332.99
ARCHITECT (Regd)	DEEN DAYAL GUPTA	
ENGINEER (Regd)		
SUPERVISOR (Regd)		
OWNER (Regd)	SMT SHANTI TOPPO	
DEVELOPMENT AUTHORITY	LOCAL BODY	

LTP NAME AND SIGNATURE	STRUCTURAL ENG'S NAME AND SIGNATURE	BUILDER NAME AND SIGNATURE	DIGITAL SIGNATURE
DEEN DAYAL GUPTA GUNPC/ENG/0002/2017			

Proposal Basic Information	
Proposal File No.	GUNPC/BP/0015/W14/2019
Owner Name	SMT SHANTI TOPPO
Khata No	34
Plot No	953
Village Name	Karam Toi
Use	Residential
SubUse	Bungalow/ Dwelling / Non Apartment

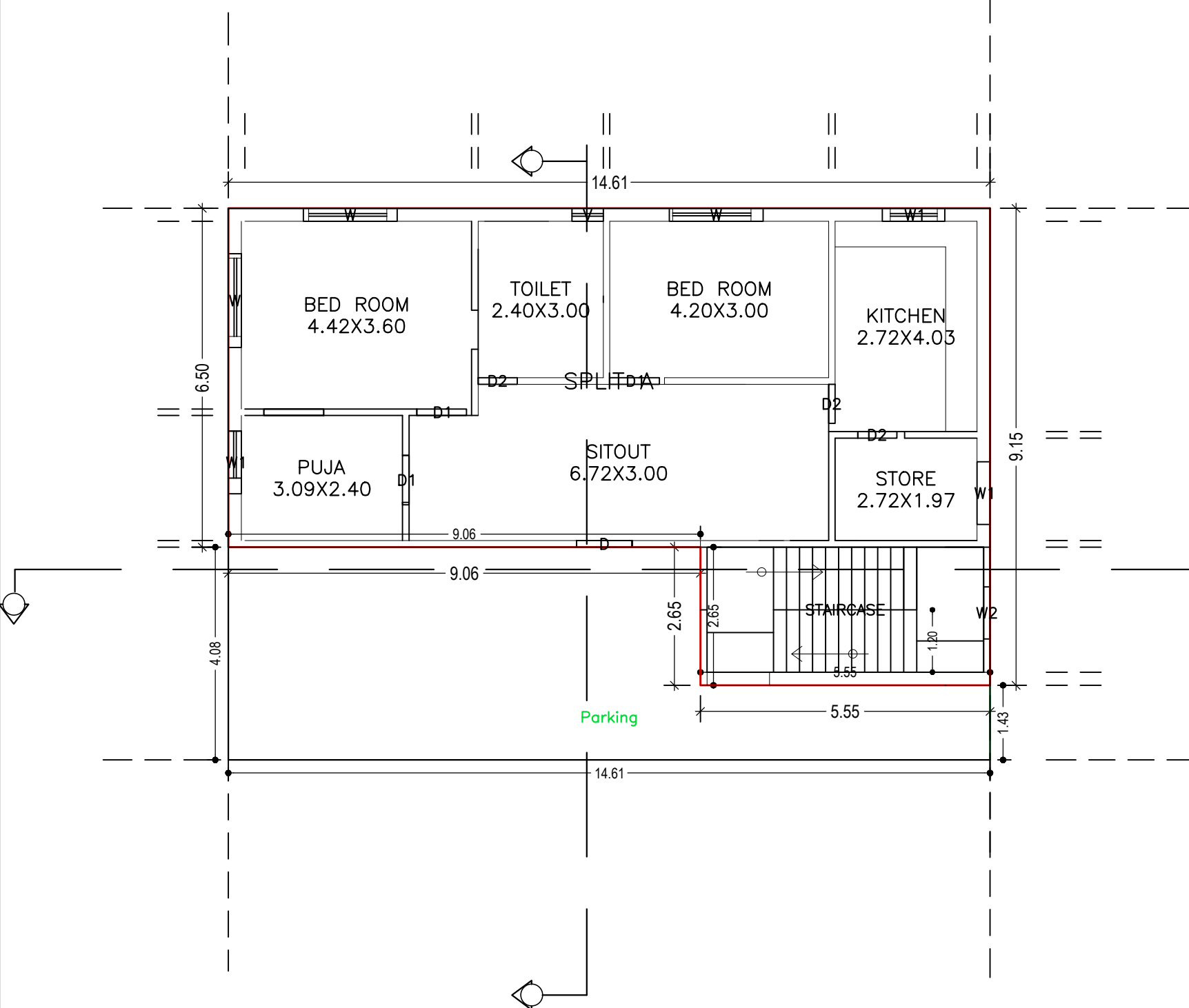

GROUND FLOOR PLAN (Proposed) (SCALE 1:100)

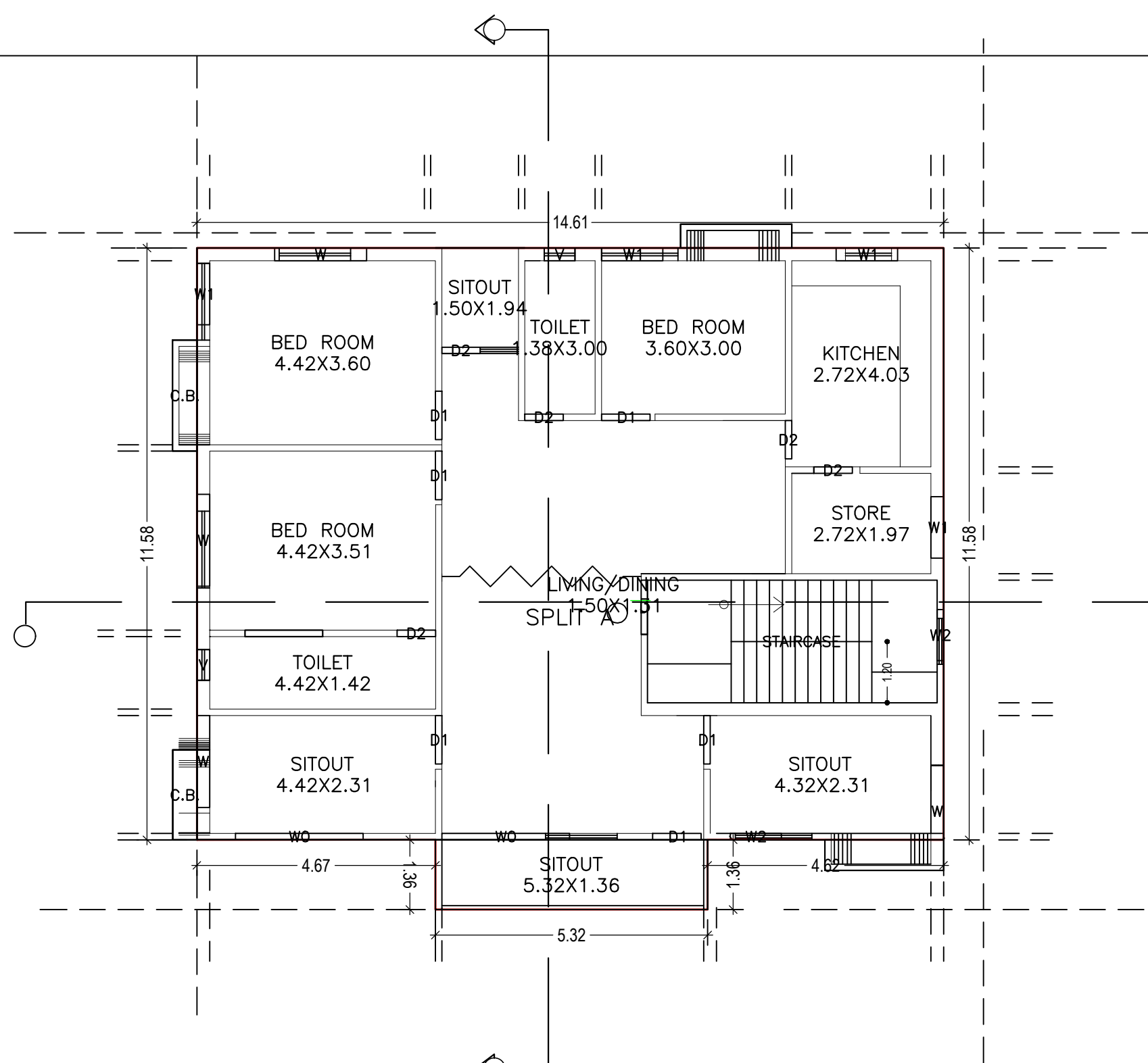

FIRST FLOOR PLAN (Proposed) (SCALE 1:100)

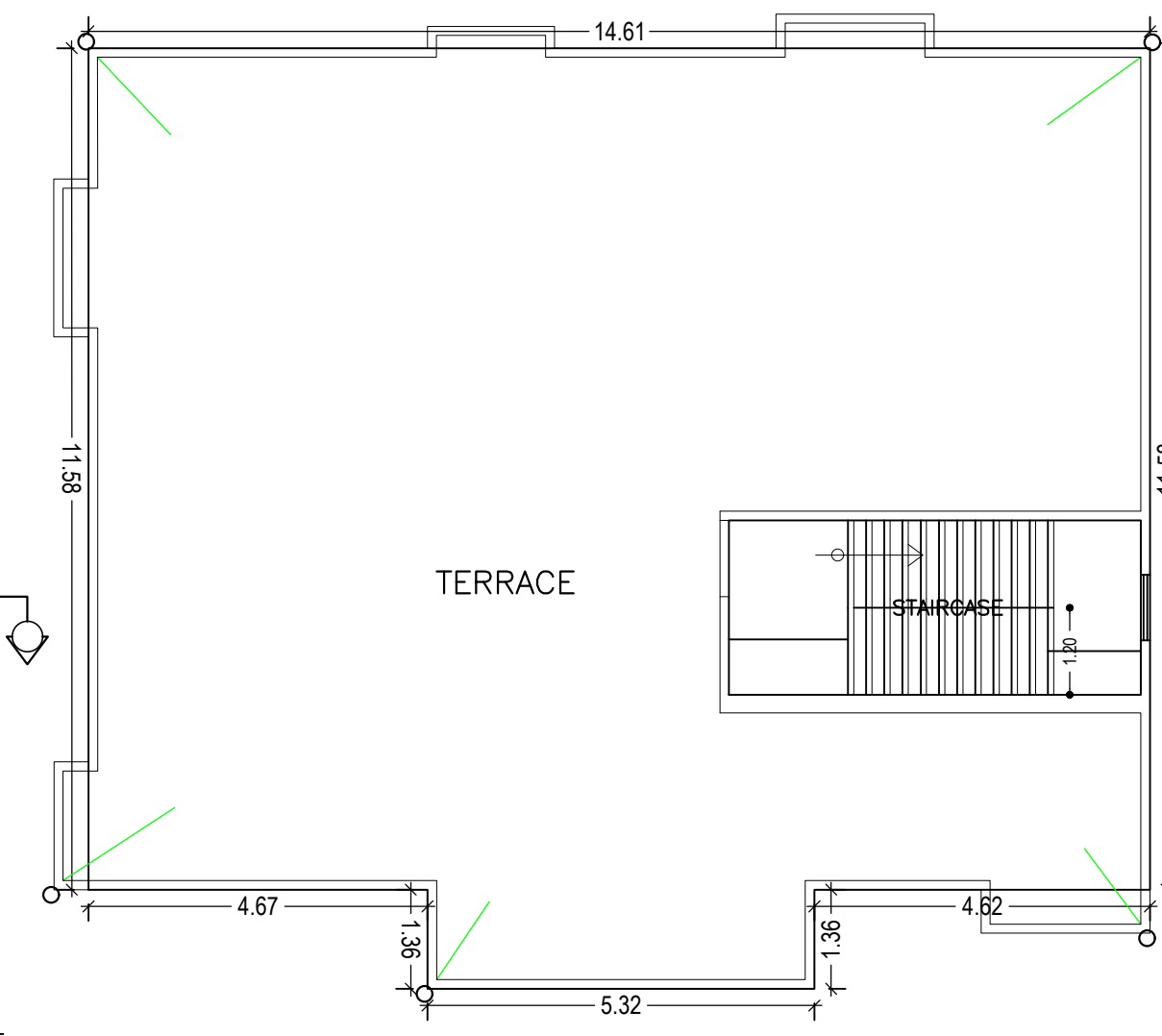

TERRACE FLOOR PLAN (SCALE 1:100)

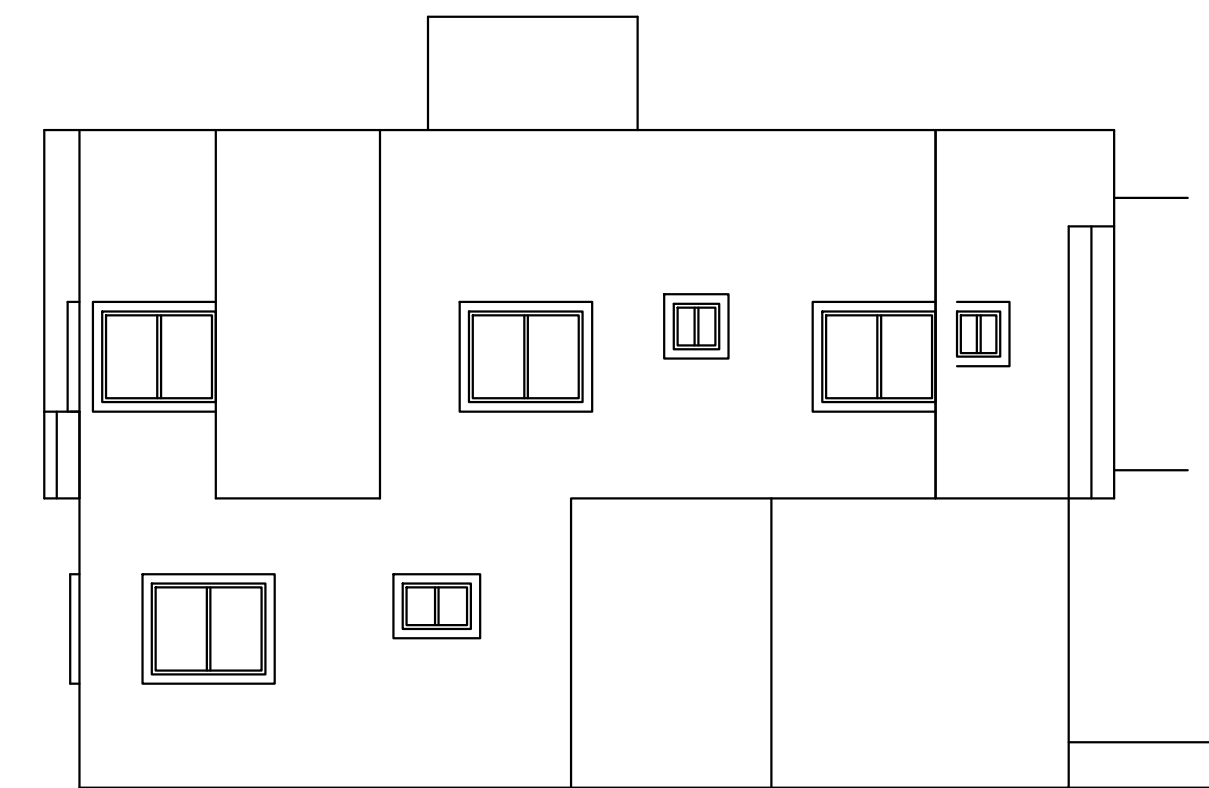

LEFT SIDE ELEVATION



FRONT ELEVATION

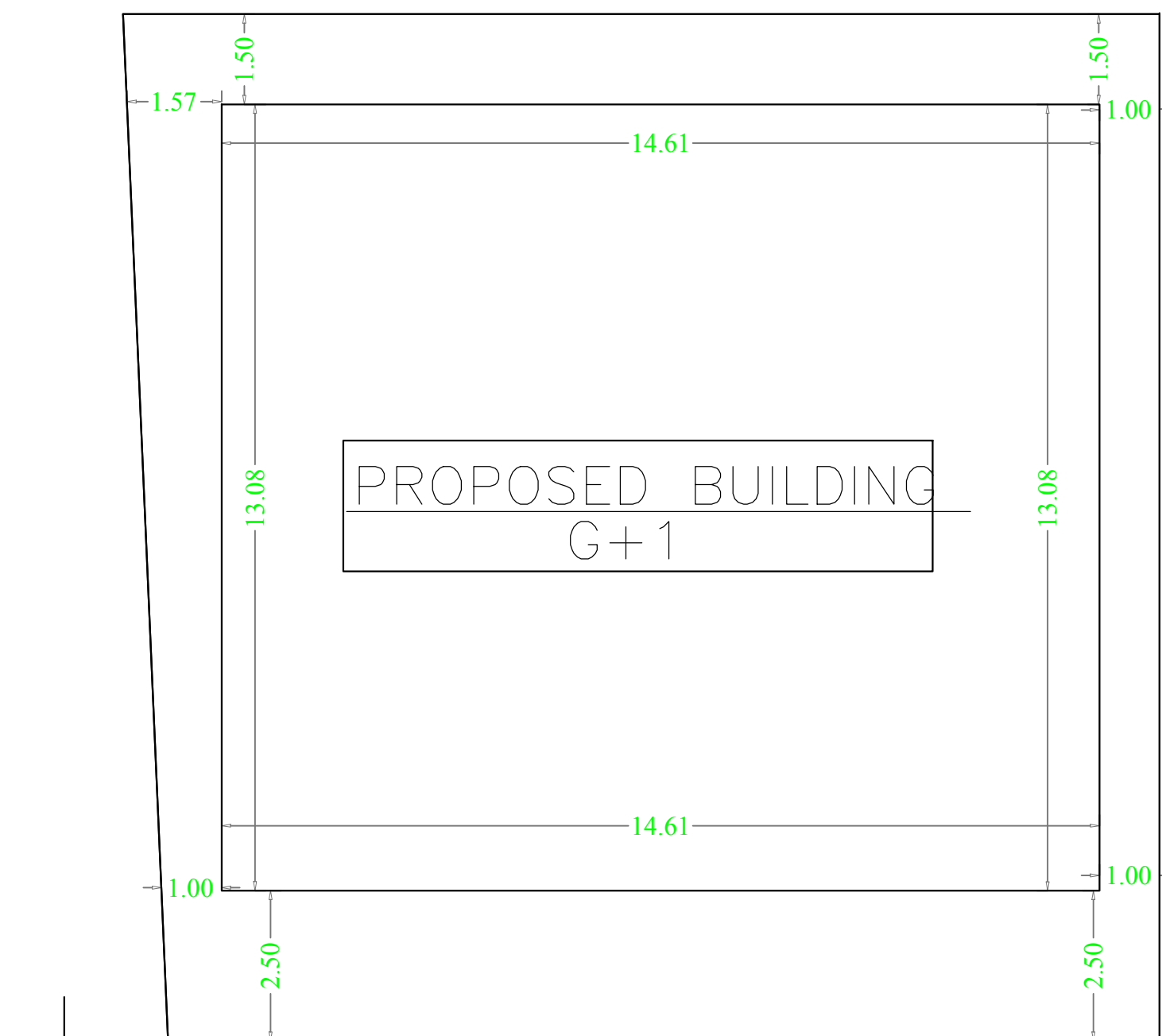

SITE PLAN

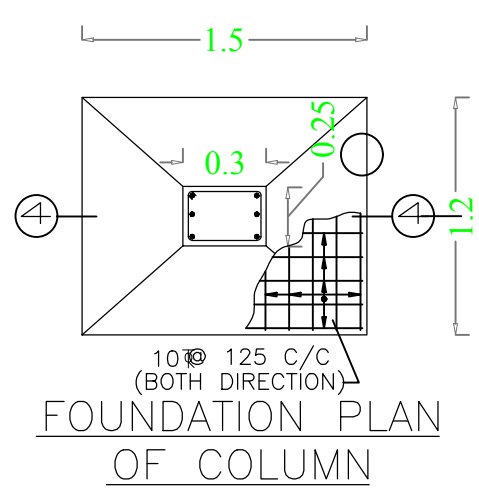

FOUNDATION PLAN OF COLUMN

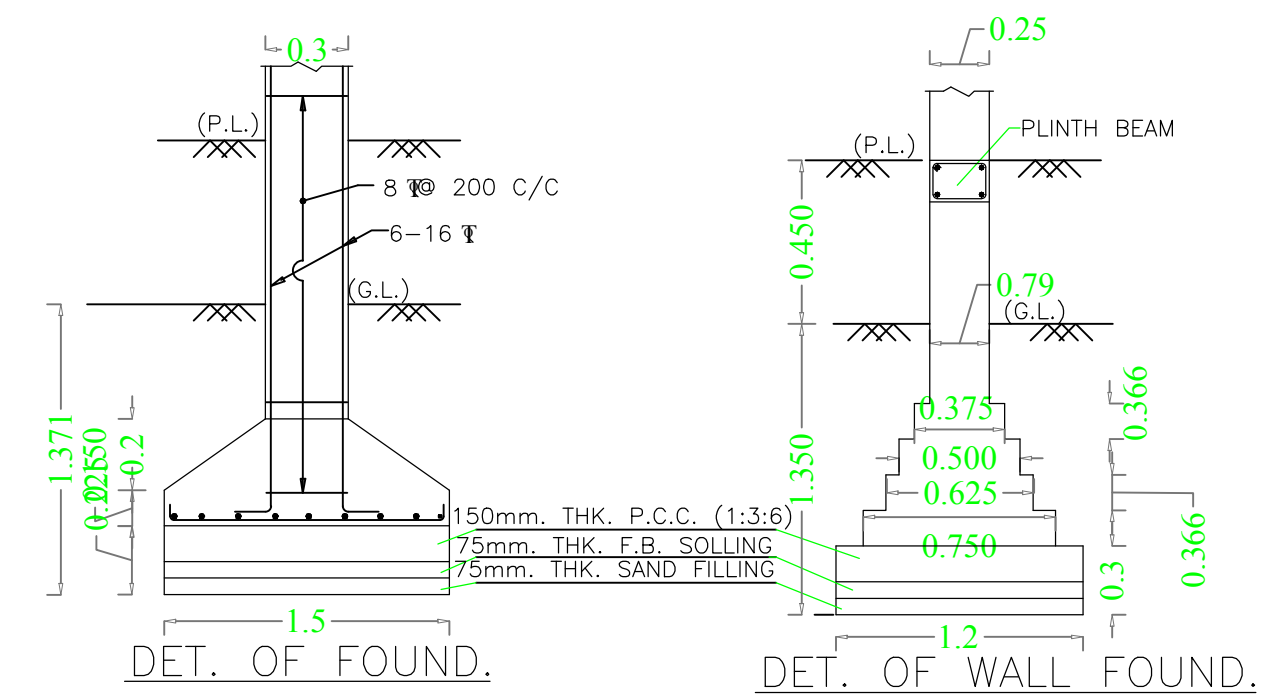

DETAIL OF FOUND.

DETAIL OF WALL FOUND.

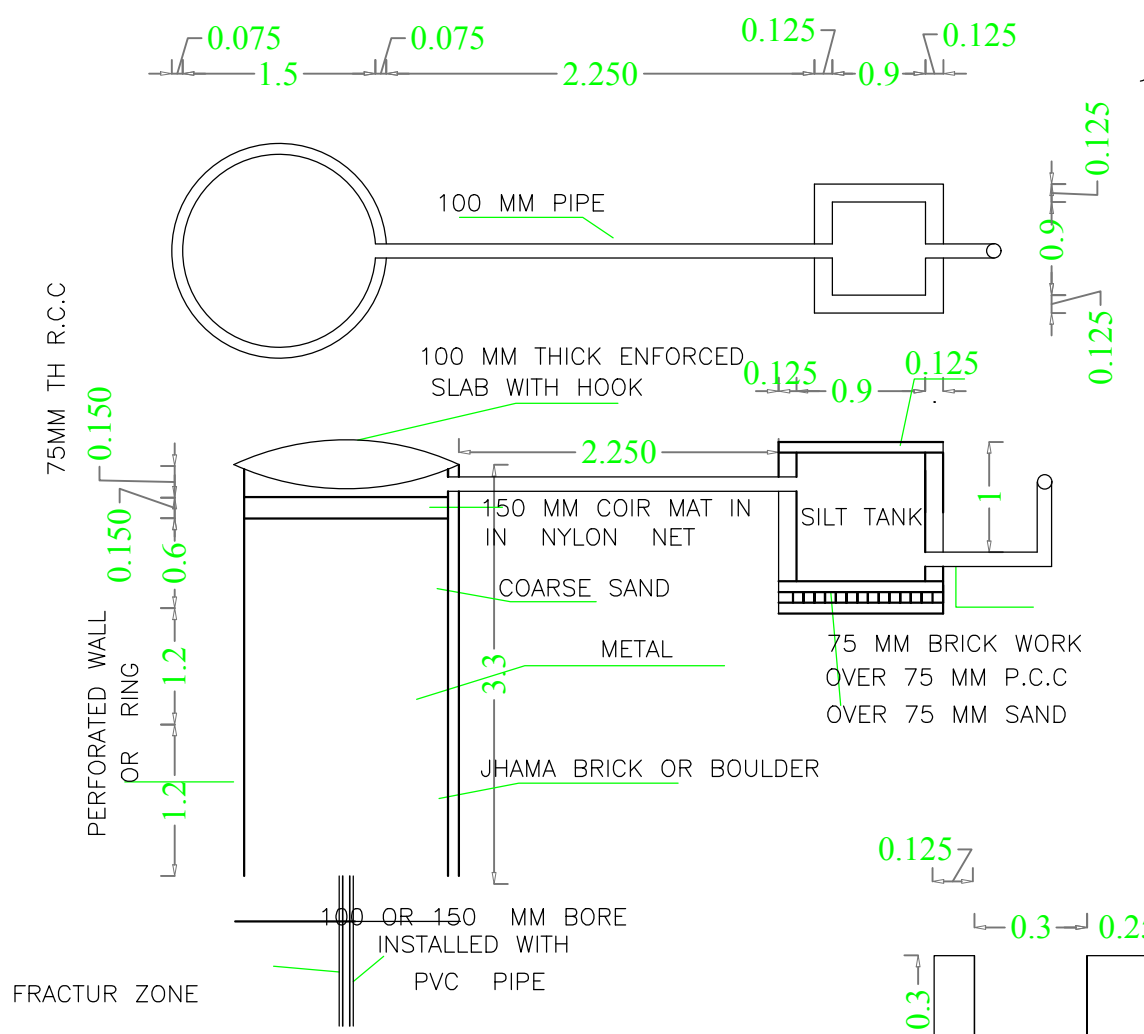

DETAIL OF RECHARGE WELL SCALE - N.T.S.

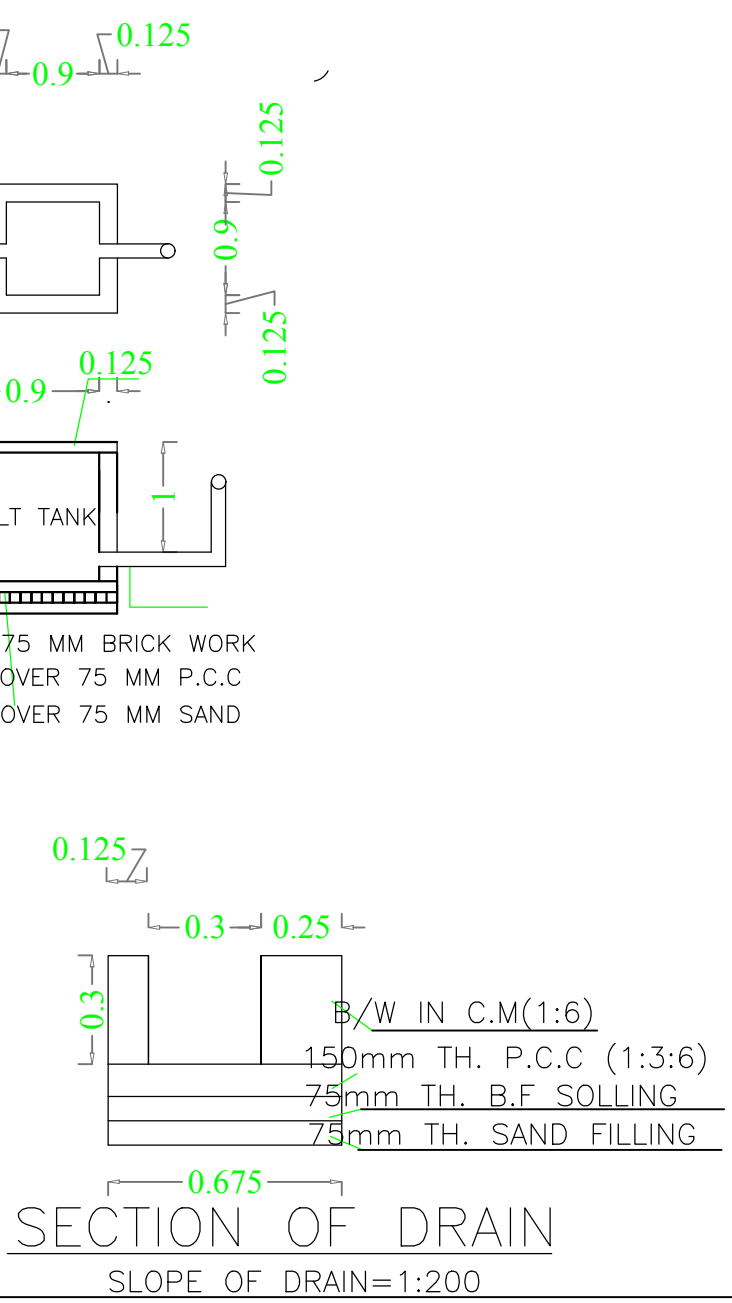

SECTION OF DRAIN SLOPE OF DRAIN=1:200

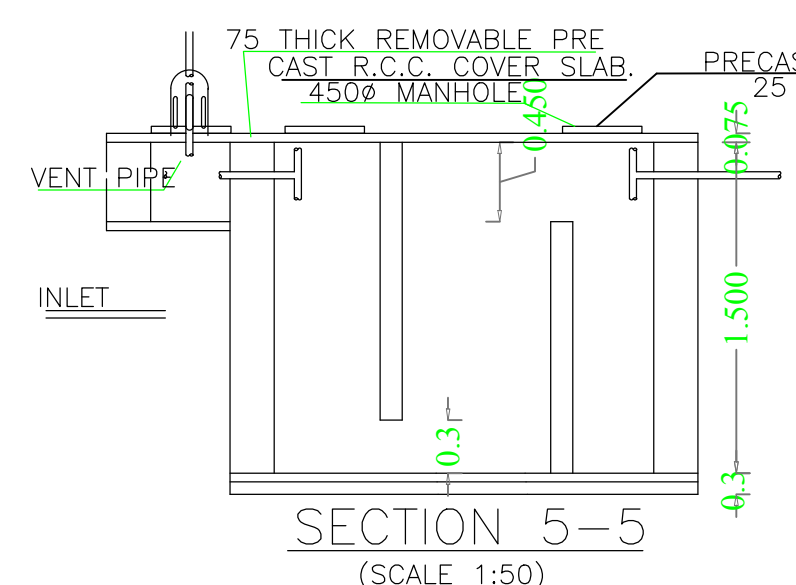

SECTION 5-5 (SCALE 1:50)

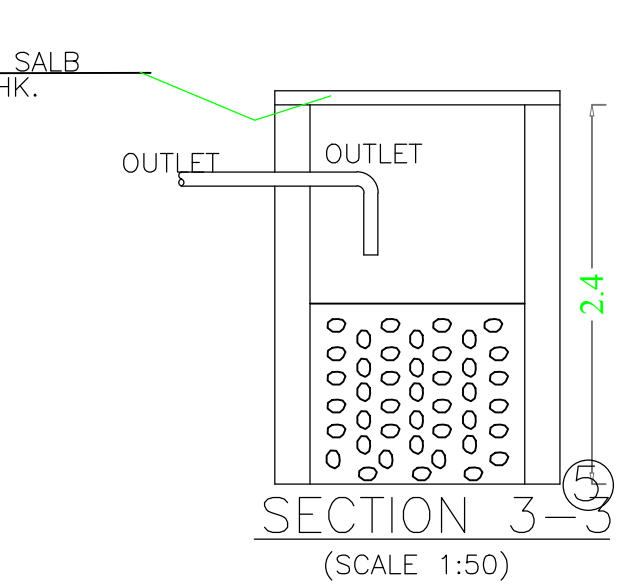

SECTION 3-3 (SCALE 1:50)

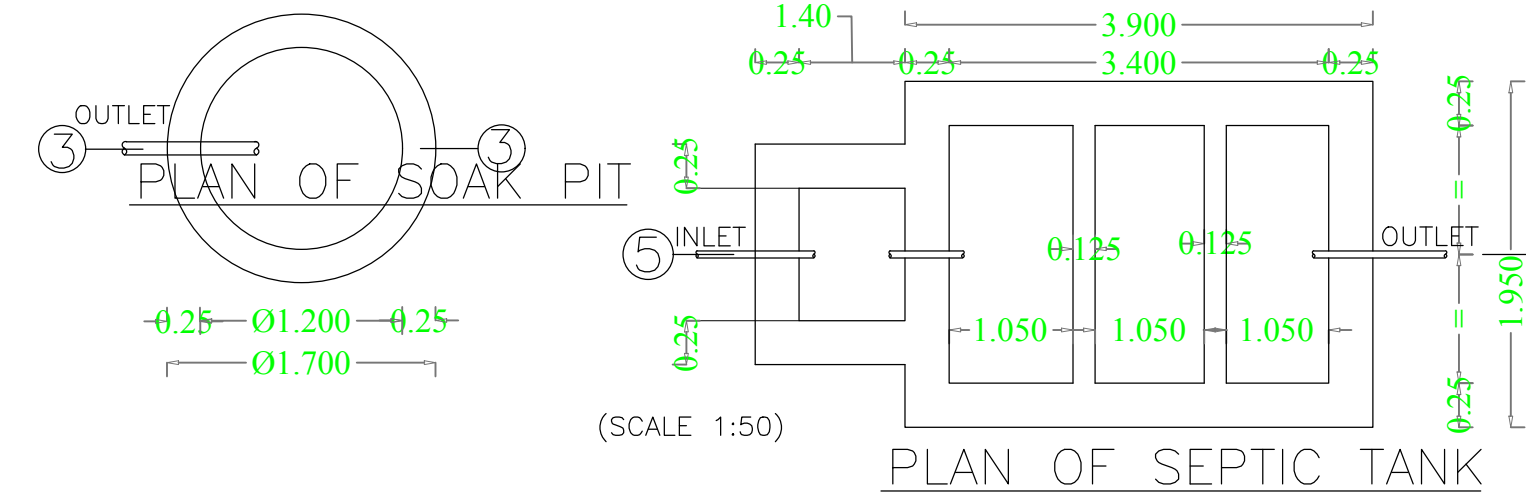

PLAN OF SOAK PIT

PLAN OF SEPTIC TANK

LTP NAME AND SIGNATURE DEEN DAYAL GUPTA GUNPC/ENG/0002/2017	STRUCTURAL ENG'S NAME AND SIGNATURE	BUILDER NAME AND SIGNATURE	DIGITAL SIGNATURE
---	-------------------------------------	----------------------------	-------------------