

Proposal Basic Information	
Proposal File No.	GUNPC/BP/0030/W02/2020
Owner Name	ANAND SAHU
Khata No	01
Plot No	392
Village Name	Dundurya
Use	Residential
SubUse	Bungalow/ Dwelling / Non Apartment

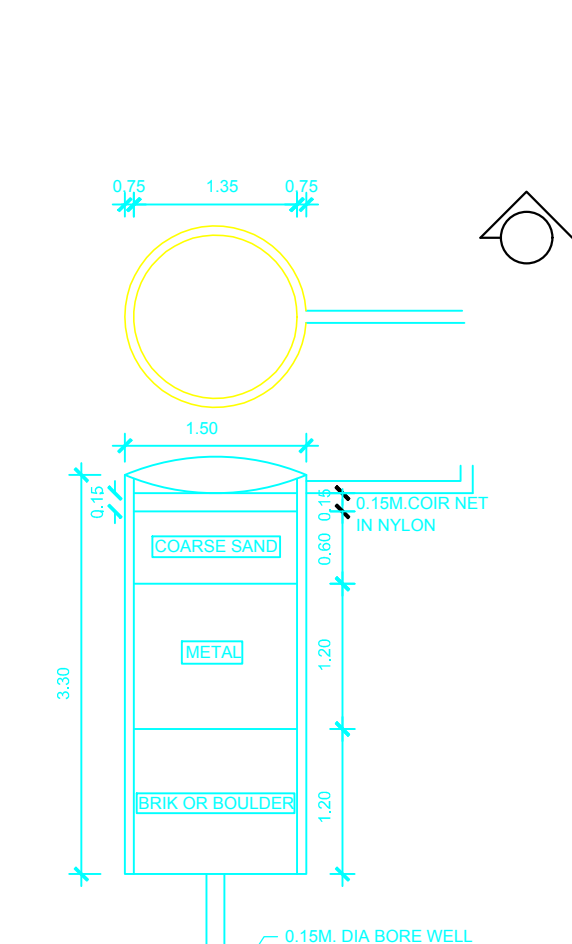

**COLOR INDEX**

PLOT BOUNDARY	[Line Style]
ABUTTING ROAD	[Line Style]
PROPOSED CONSTRUCTION	[Line Style]
COMMON PLOT	[Line Style]
ROAD WIDENING AREA	[Line Style]
EXISTING (To be retained)	[Line Style]
EXISTING (To be demolished)	[Line Style]

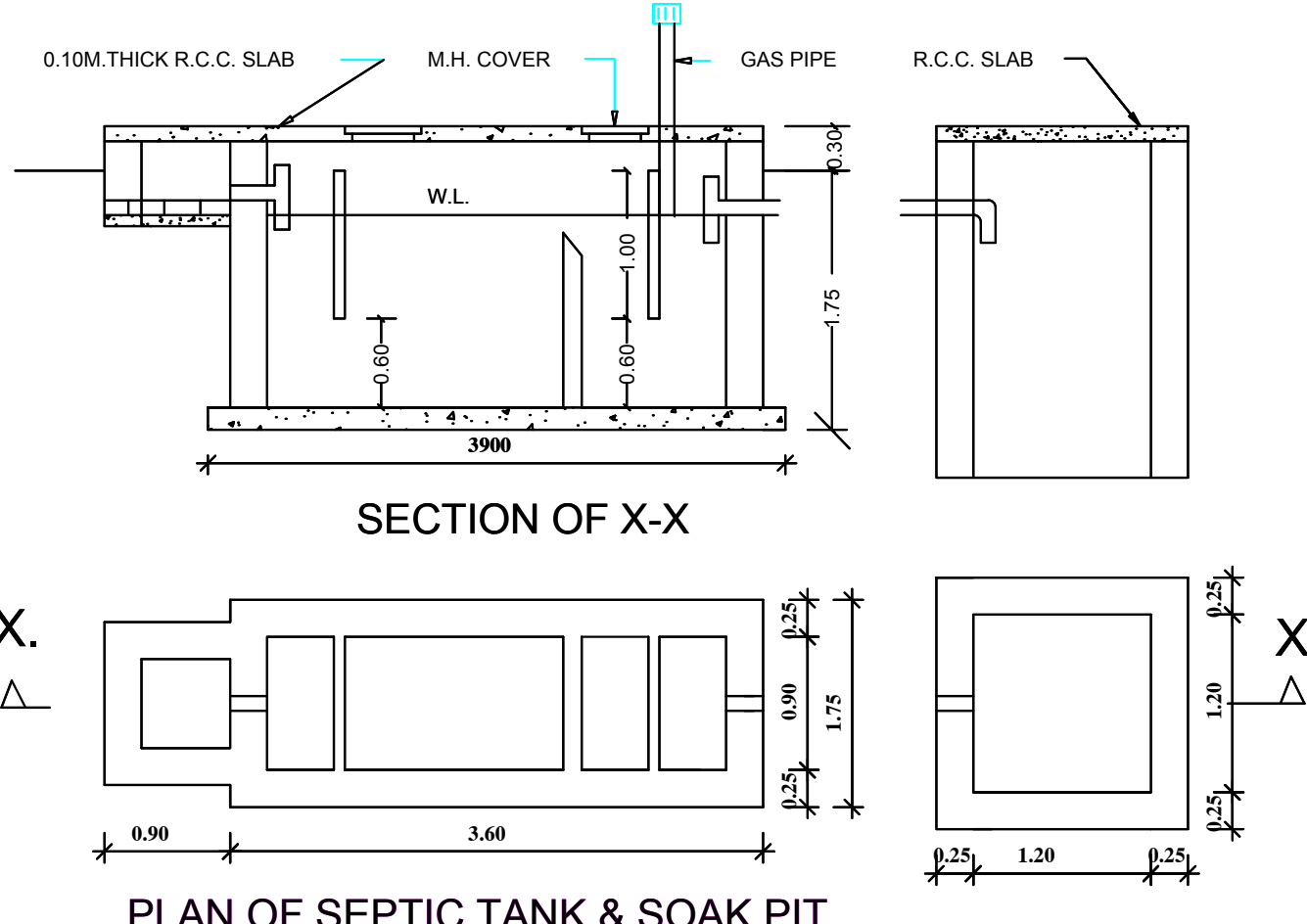
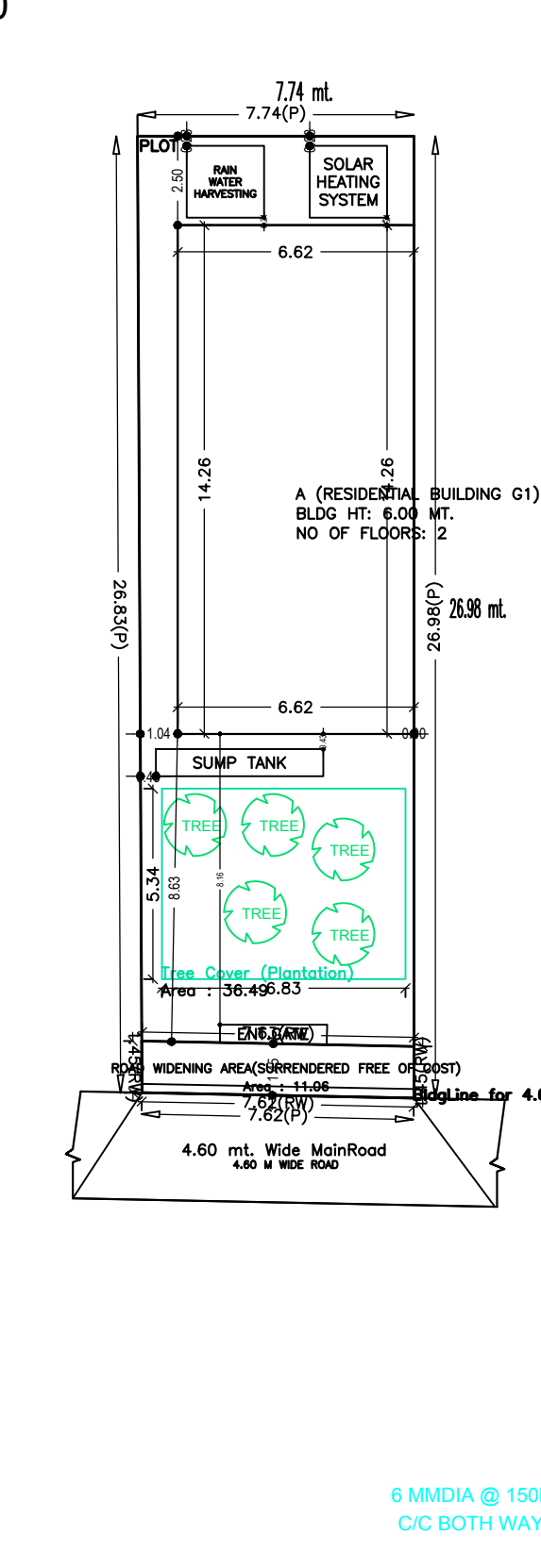
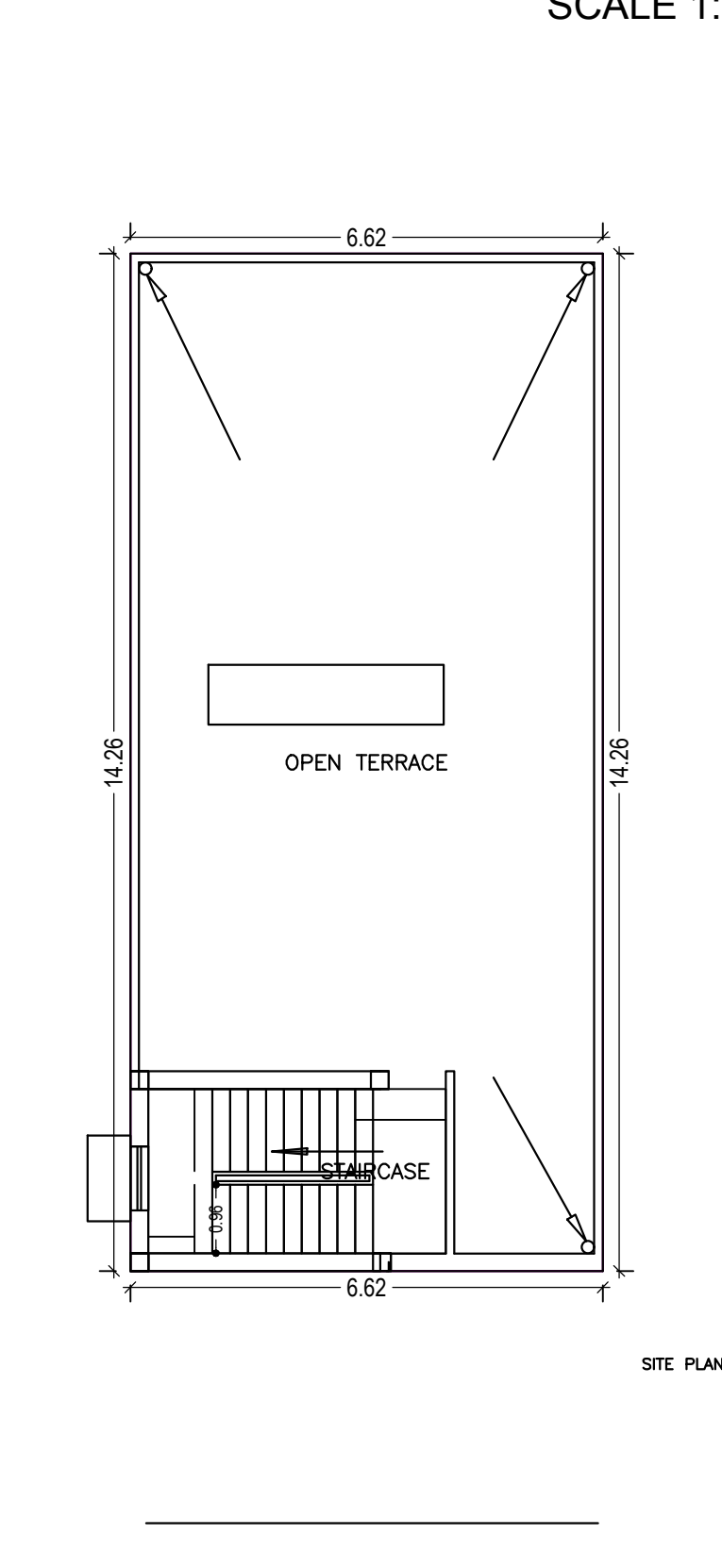
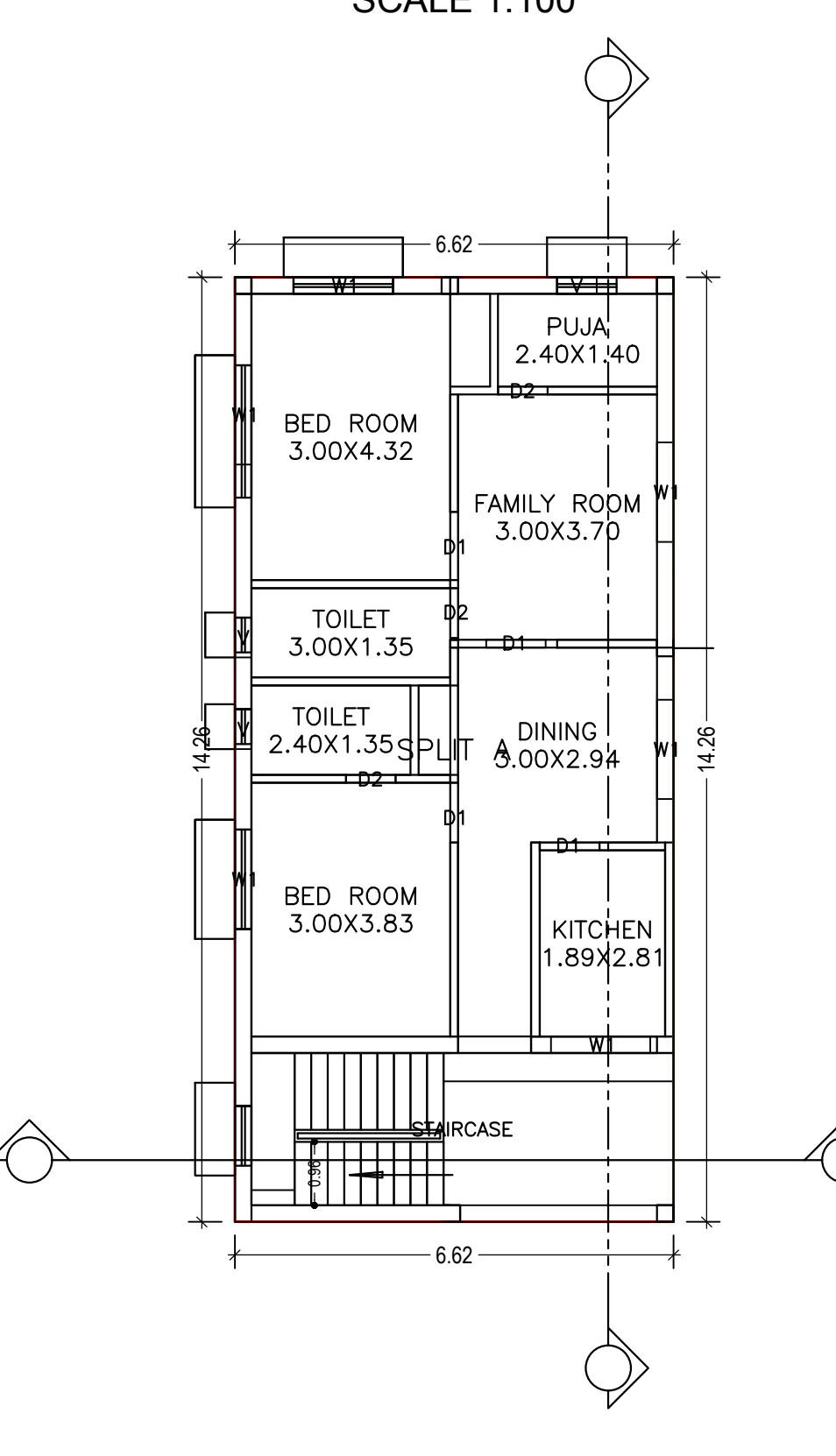
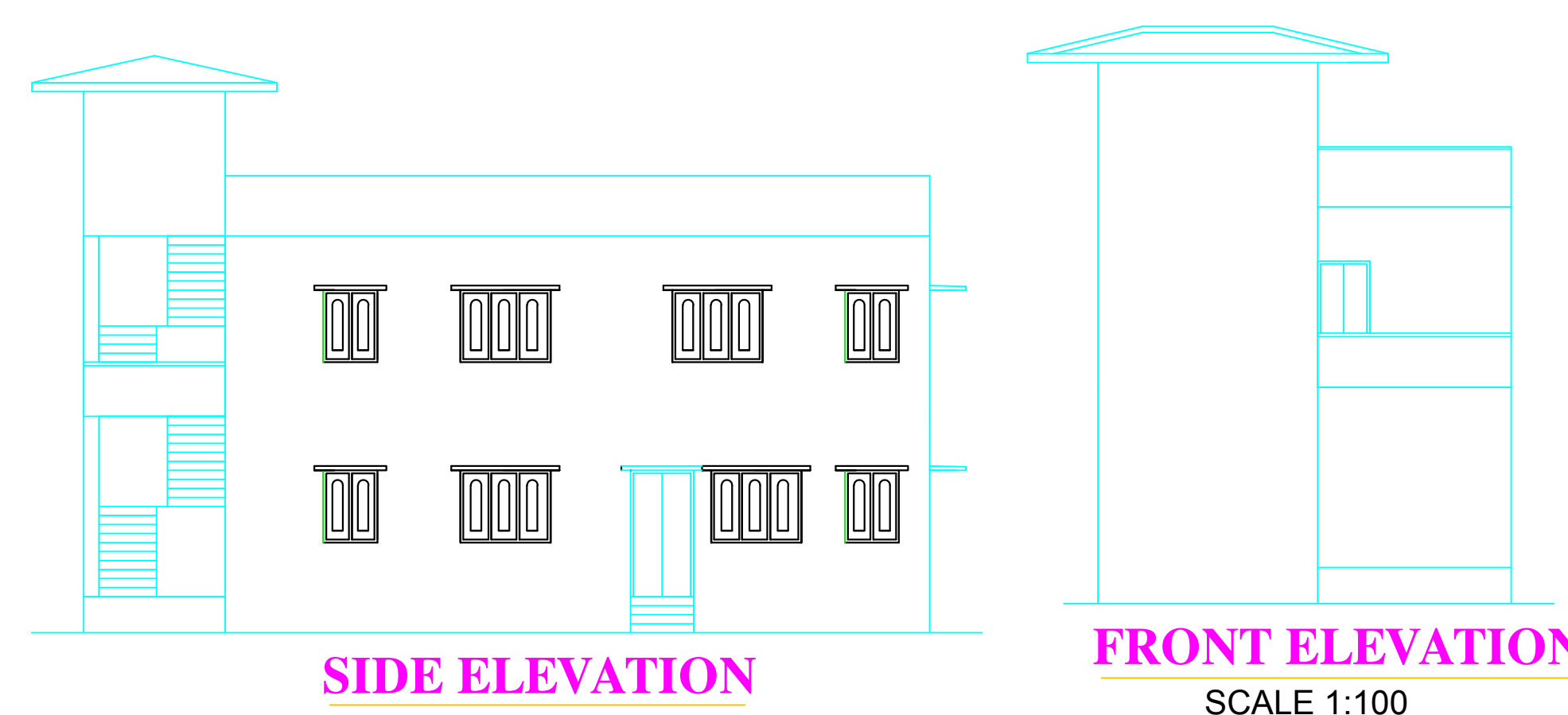
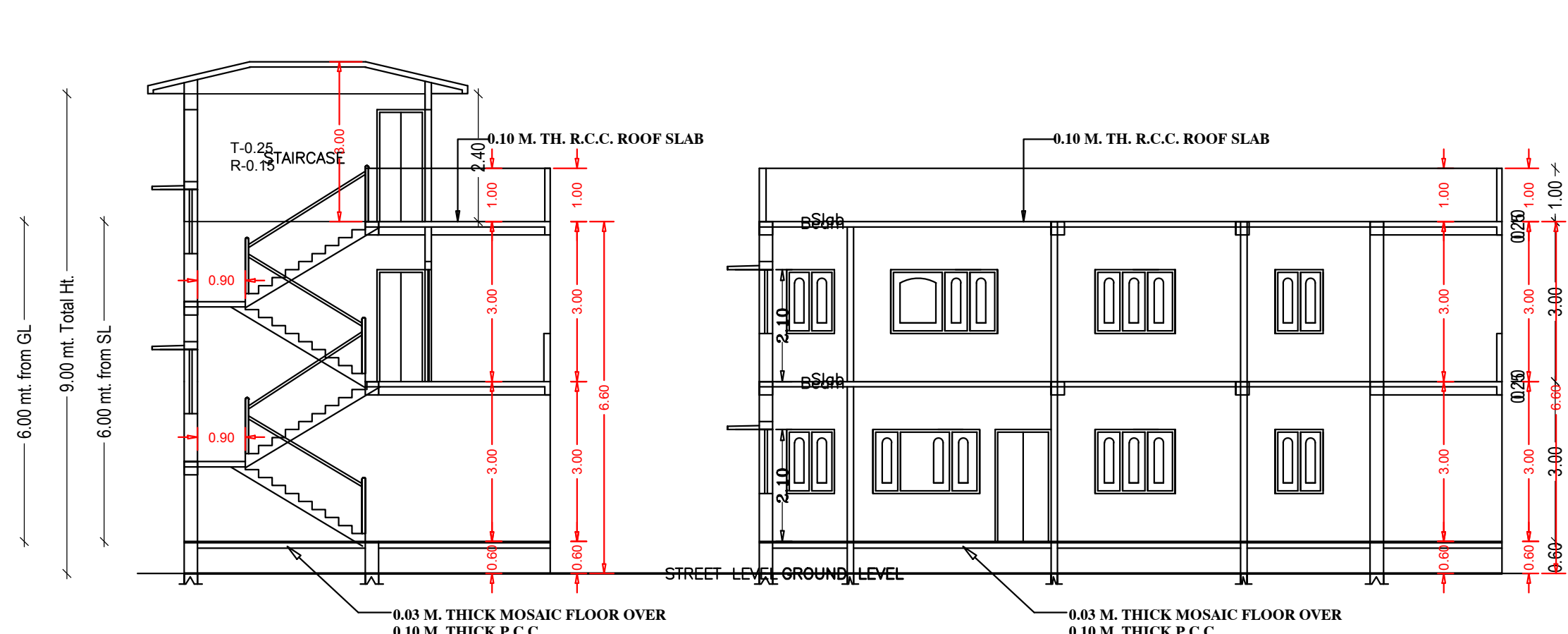
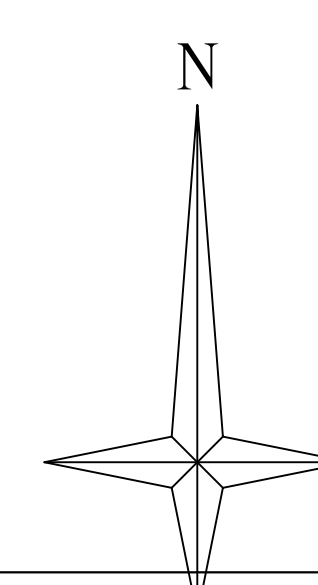

AREA STATEMENT GUMLA NAGAR PARISHAD		VERSION NO. : 1.0.46
		VERSION DATE: 22/06/2020
<b>PROJECT DETAIL:</b>		
Region: JHARKHAND URBAN LOCAL BODIES	Plot Use: Residential	
District: GUMLA	Plot SubUse: Bungalow/ Dwelling / Non Apartment	
Authority: GUMLA NAGAR PARISHAD	PlotNearby/ReligiousStructure: NA	
Inward No: GUNPC/BP/0030/W02/2020	Plot/SubPlot No: 392	
Application Type: General Proposal	North: Plot No. - 548, 555	
Project Type: Building Permission	South: Road Width - 4.570	
Nature of Development: New	East: Plot No. - 392	
Location of Development Area: Old Area	West: Plot No. - 392	
<b>AREA DETAILS:</b>		
AREA OF PLOT (Minimum)	(A)	205.20 SQ.MT.
Deduction for NetPlot Area		
Surrender Free of Cost		11.06
Total		11.06
NET AREA OF PLOT(Gross Plot Area - Deduction from Gross Plot area)	(A-Deductions)	194.14
Deduction for Balance Plot Area(from Gross Plot Area)		
Surrender Free of Cost		11.06
Common Plot		36.49
Total		47.55
BALANCE AREA OF PLOT(Net Plot Area - Recreational/Amenity space)	(A-Deductions)	157.65
PLOT AREA FOR COVERAGE(Net Plot Area)	(A-Deductions)	194.14
Plot Area for FAR (Net Plot Area + RoadWidening Area)	(A-Deductions)	205.20
<b>COVERAGE CHECK</b>		
Permissible Coverage area ( 70.00 % )		135.90
Proposed Coverage Area ( 48.65 % )		94.45
Total Prop. Coverage Area ( 48.65 % )		94.45
Balance coverage area ( 21.35 % )		41.45
<b>FAR CHECK</b>		
Perm. FAR Area ( 1.50 )		307.80
Total Perm. FAR area		307.80
Residential FAR		188.90
Proposed FAR Area		188.90
Total Proposed FAR Area		188.90
Consumed FAR (Factor)		0.92
Balance FAR Area		118.90
<b>BUILT UP AREA CHECK</b>		
Total Proposed BuiltUp Area		188.90
<b>ARCHITECT (Regd)</b>		
UMESH LAKRA		
<b>ENGINEER (Regd)</b>		
ANAND SAHU		
<b>SUPERVISOR (Regd)</b>		
<b>OWNER (Regd)</b>		
DEVELOPMENT AUTHORITY		LOCAL BODY

**Buildingwise Floor FAR Details**

Floor Name	Building Name		Total	
	A (RESIDENTIAL BUILDING G1)	Proposed FAR Area (Sq.mt.)	Total Proposed Built Up Area (Sq.mt.)	Total FAR Area (Sq.mt.)
Ground Floor	94.45	94.45	94.45	94.45
First Floor	94.45	94.45	94.45	94.45
Terrace Floor	0.00	0.00	0.00	0.00
Total :	188.90	188.90	188.90	188.90

**Building USE/SUBUSE Details**

Building Name	Building Use	Building SubUse	Building Structure
A (RESIDENTIAL BUILDING G1)	Residential	Bungalow/ Dwelling / Non Apartment	Non-Highrise

**SCHEDULE OF DOOR:**

BUILDING NAME	NAME	LENGTH	HEIGHT	NOS
A (RESIDENTIAL BUILDING G1)	D2	0.75	2.10	06
A (RESIDENTIAL BUILDING G1)	D1	0.90	2.10	06
A (RESIDENTIAL BUILDING G1)	D1	1.03	2.10	02

**SCHEDULE OF WINDOW/VENTILATION:**

BUILDING NAME	NAME	LENGTH	HEIGHT	NOS
A (RESIDENTIAL BUILDING G1)	V	0.60	1.20	06
A (RESIDENTIAL BUILDING G1)	W1	1.20	1.20	01
A (RESIDENTIAL BUILDING G1)	W1	1.50	1.20	11

**FAR & Tenement Details (Table 4c-1)**

Building	No. of Same Bldg	Total Built Up Area (Sq.mt.)	Proposed FAR Area (Sq.mt.)	Total FAR Area (Sq.mt.)	Total Consumed Additional FAR Area (Sq.mt.)	Tnmt (No.)
A (RESIDENTIAL BUILDING G1)	1	188.90	188.90	188.90	188.90	01
Grand Total :	1	188.90	188.90	188.90	188.90	01

**Building :A (RESIDENTIAL BUILDING G1)**

Floor Name	Total Built Up Area (Sq.mt.)	Proposed FAR Area (Sq.mt.)	Total FAR Area (Sq.mt.)	Total Consumed Additional FAR Area (Sq.mt.)	Tnmt (No.)
Ground Floor	94.45	94.45	94.45	94.45	01
First Floor	94.45	94.45	94.45	94.45	00
Terrace Floor	0.00	0.00	0.00	0.00	00
Total	188.90	188.90	188.90	188.90	01
Total Number of Same Buildings	1	188.90	188.90	188.90	01
Total :	188.90	188.90	188.90	188.90	01

**UnitBUA Table for Building :A (RESIDENTIAL BUILDING G1)**

FLOOR	Name	UnitBUA Type	UnitBUA Area	Carpet Area	No. of Rooms	No. of Tenement
GROUND FLOOR PLAN	SPLIT A	FLAT	188.90	168.49	8	1
FIRST FLOOR PLAN	SPLIT A	FLAT	0.00	0.00	8	0
Total:	-	-	188.90	168.49	16	1

