

Proposal Basic Information

Proposal File No.	GUNPC/BP/0056/W17/2020
Owner Name	BAHURA MAHLI
Khata No	86
Plot No	850
Village Name	Gokul Nagar
Use	Residential
SubUse	Bungalow/ Dwelling / Non Apartment

Building USE/SUBUSE Details

Building Name	Building Use	Building SubUse	Building Structure
A (A)	Residential	Bungalow/ Dwelling / Non Apartment	Non-Highrise

(SCALE 1:100)

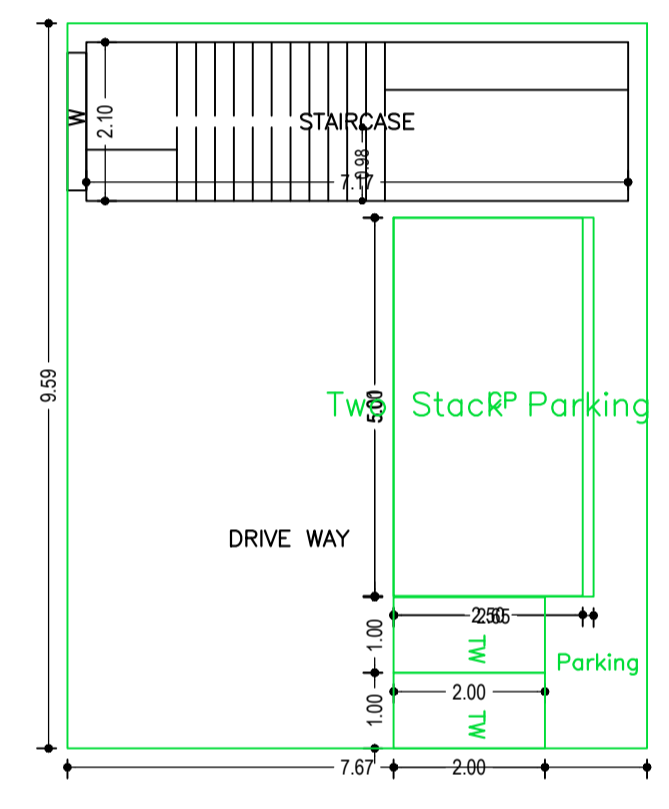
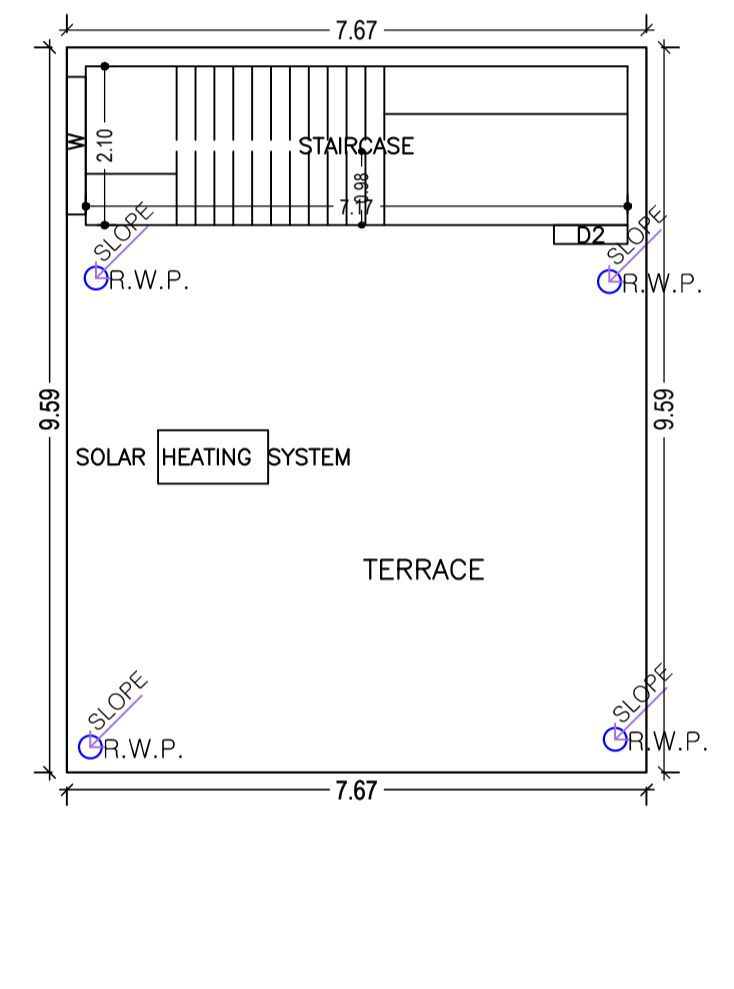

TERRACE FLOOR PLAN (SCALE 1:100)

GROUND FLOOR PLAN (SCALE 1:100)

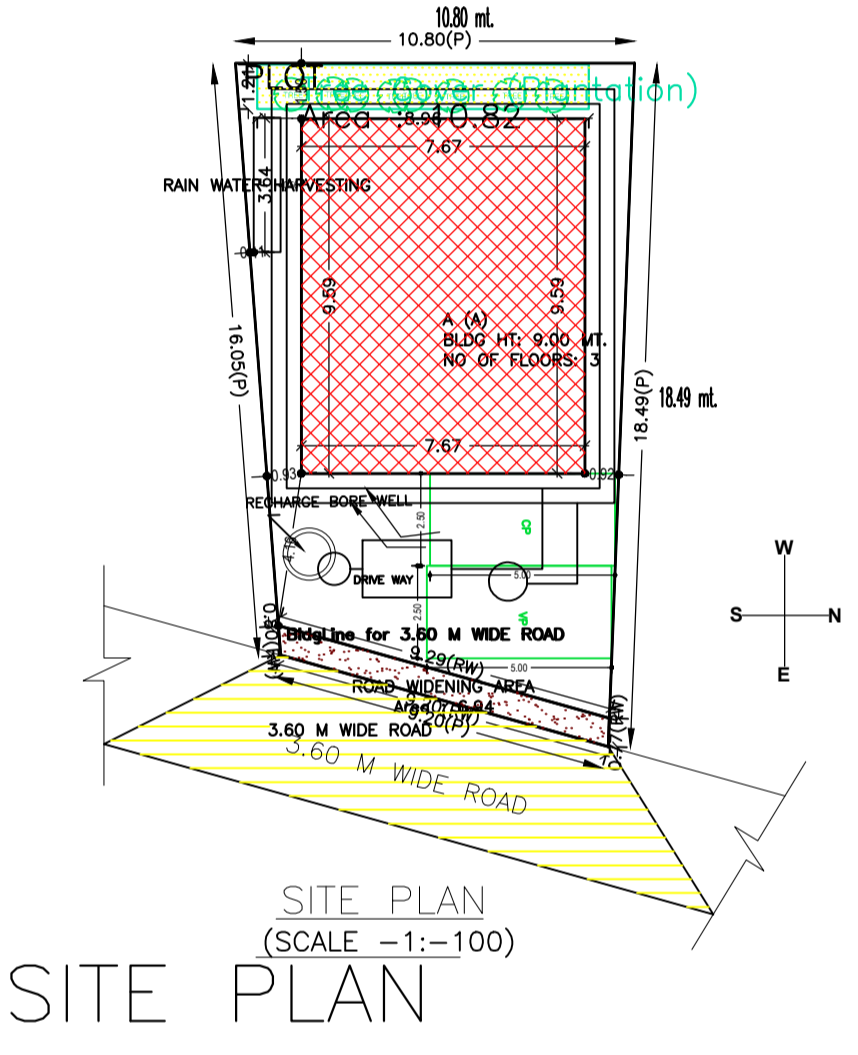
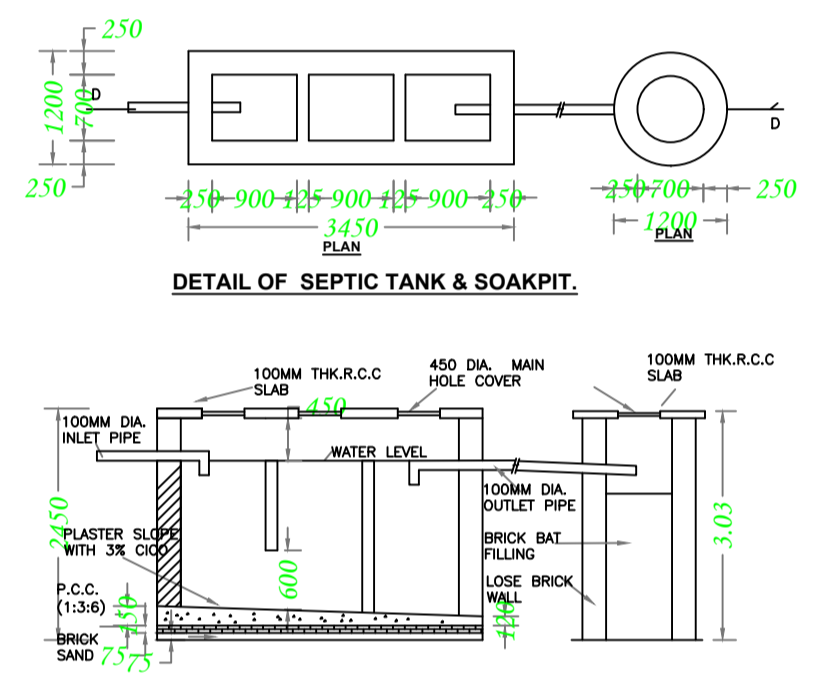

SITE PLAN (SCALE 1:100)

Buildingwise Floor FAR Details

Floor Name	Building Name A (A)		Total	
	Proposed Built Up Area (Sq.mt.)	Proposed FAR Area (Sq.mt.)	Total Proposed Built Up Area (Sq.mt.)	Total FAR Area (Sq.mt.)
Ground Floor	73.53	15.05	73.53	15.05
First Floor	73.53	73.53	73.53	73.53
Second Floor	73.53	73.53	73.53	73.53
Terrace Floor	0.00	0.00	0.00	0.00
<b>Total</b>	<b>220.59</b>	<b>162.11</b>	<b>220.59</b>	<b>162.11</b>

COLOR INDEX

PLOT BOUNDARY	Black
ABUTTING ROAD	Green
PROPOSED CONSTRUCTION	Red
COMMON PLOT	Yellow
ROAD WIDENING AREA	Blue
EXISTING (To be retained)	Orange
EXISTING (To be demolished)	Light Blue

AREA STATEMENT GUMLA NAGAR PARISHAD

Version No.	1.0.53	
Version Date	16/10/2020	
Region	JHARKHAND URBAN LOCAL BODIES	
District	GUMLA	
Authority	GUMLA NAGAR PARISHAD	
Inward No.	GUNPCBP/0056/W17/2020	
Plot/Religious Structure	Plot/Religious Structure: NA	
Plot/SubPlot No.	850	
Application Type	General Proposal	
Project Type	Building Permission	
Nature of Development	New	
Location of Development Area	Old Area	
Area Details		
AREA OF PLOT (Minimum)	(A)	123.75
Deduction for NetPlot Area		
Road Widening Area		6.94
Total		6.94
NET AREA OF PLOT(Gross Plot Area - Deduction from Gross Plot Area)	(A-Deductions)	116.81
Deduction for Balance Plot Area(from Gross Plot Area)		
Road Widening Area		6.94
Common Plot		10.82
Total		17.76
BALANCE AREA OF PLOT(Net Plot Area - Recreational/Amenity space)	(A-Deductions)	105.99
PLOT AREA FOR COVERAGE(Net Plot Area)	(A-Deductions)	116.81
Plot Area for FAR (Net Plot Area + RoadWidening Area)	(A-Deductions)	116.81
COVERAGE CHECK		
Permissible Coverage area ( 70.00 % )		81.77
Proposed Coverage Area ( 62.95 % )		73.53
Total Prop. Coverage Area ( 62.95 % )		73.53
Balance coverage area ( 7.05 % )		8.24
FAR CHECK		
Perm. FAR Area ( 1.50 )		175.21
Total Perm. FAR area		175.21
Residential FAR area		147.06
Proposed FAR Area		162.12
Total Proposed FAR Area		162.12
Consumed FAR (Factor)		1.39
Balance FAR Area		13.09
BUILT UP AREA CHECK		
Total Proposed BuiltUp Area		220.59
ARCHITECT (Regd)		DEEPAK DIWAN
ENGINEER (Regd)		
SUPERVISOR (Regd)		BAHURA MAHLI
OWNER (Regd)		
DEVELOPMENT AUTHORITY		LOCAL BODY

FAR & Tenement Details (Table 4c-1)

Building	No. of Same Bldg	Total Built Up Area (Sq.mt.)	Deductions (Area in Sq.mt.)		Proposed FAR Area (Sq.mt.)	Add Area in FAR (Sq.mt.)	Total FAR Area (Sq.mt.)	Total Consumed Additional FAR Area (Sq.mt.)	Tnmt (No.)
			Parking	Stair					
A (A)	1	220.59	58.48	147.06	15.05	162.11	162.11	02	
<b>Grand Total :</b>	<b>1</b>	<b>220.59</b>	<b>58.48</b>	<b>147.06</b>	<b>15.05</b>	<b>162.11</b>	<b>162.11</b>	<b>02</b>	

UnitBUA Table for Building :A (A)

FLOOR	Name	UnitBUA Type	UnitBUA Area	Carpet Area	No. of Rooms	No. of Tenement
TYPICAL - 1& 2 FLOOR PLAN	SPLIT A	FLAT	65.15	61.33	5	2
Total	-	-	130.31	122.66	10	2

Required Parking(Table 7a)

Building Name	Type	SubUse	Area (Sq.mt.)	Units		Car		Visitors Car		TwoWheeler	
				Reqd.	Prop.	Reqd./Unit	Prop.	Reqd./Unit	Prop.	Reqd./Unit	Prop.
A (A)	Residential	Bungalow/ Dwelling / Non Apartment	> 0	1	2.00	1	2	-	-	-	-
			> 0	1	2.00	-	-	1	1	-	-
<b>Total</b>											

Parking Check (Table 7b)

Vehicle Type	Reqd.		Prop.	
	No.	Area	No.	Area
Car	-	-	2	25.00
Two Stack Car	-	-	1	12.50
Total Car	2	25.00	3	37.50
Visitor's Car Parking	-	-	1	12.50
Total Visitor Parking	1	12.50	1	12.50
TwoWheeler	-	-	2	4.00
Total TwoWheeler	-	-	2	4.00
Other Parking	-	-	-	41.98
<b>Total</b>		37.50		99.98

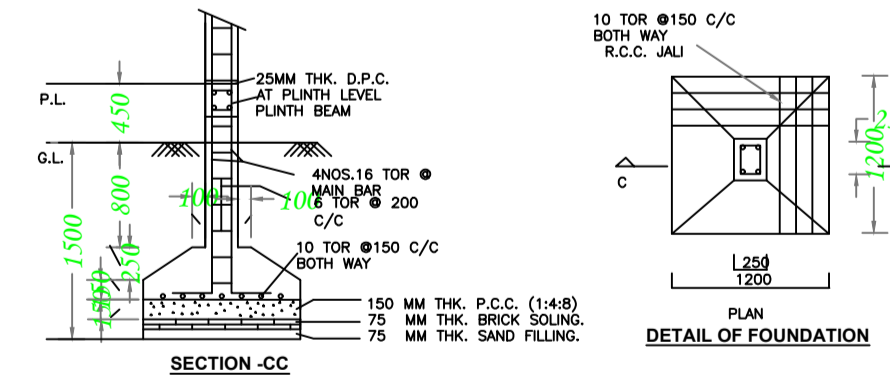

SCHEDULE OF DOOR:

BUILDING NAME	NAME	LENGTH	HEIGHT	NOS
A (A)	D	0.75	2.10	02
A (A)	D2	0.91	2.10	04
A (A)	D2	0.98	2.10	02
A (A)	D1	1.07	2.10	02

SCHEDULE OF WINDOW/VENTILATION:

BUILDING NAME	NAME	LENGTH	HEIGHT	NOS
A (A)	W1	0.60	0.60	02
A (A)	W	1.82	2.70	16

Building :A (A)

Floor Name	Total Built Up Area (Sq.mt.)	Deductions (Area in Sq.mt.)		Proposed FAR Area (Sq.mt.)	Add Area in FAR (Sq.mt.)	Total FAR Area (Sq.mt.)	Total Consumed Additional FAR Area (Sq.mt.)	Tnmt (No.)
		Parking	Stair					
Ground Floor	73.53	58.48	0.00	15.05	15.05	15.05	00	
First Floor	73.53	0.00	73.53	0.00	73.53	73.53	01	
Second Floor	73.53	0.00	73.53	0.00	73.53	73.53	01	
Terrace Floor	0.00	0.00	0.00	0.00	0.00	0.00	00	
<b>Total :</b>	<b>220.59</b>	<b>58.48</b>	<b>147.06</b>	<b>15.05</b>	<b>162.11</b>	<b>162.11</b>	<b>02</b>	
Total Number of Same Buildings	1							
<b>Total :</b>	<b>220.59</b>	<b>58.48</b>	<b>147.06</b>	<b>15.05</b>	<b>162.11</b>	<b>162.11</b>	<b>02</b>	

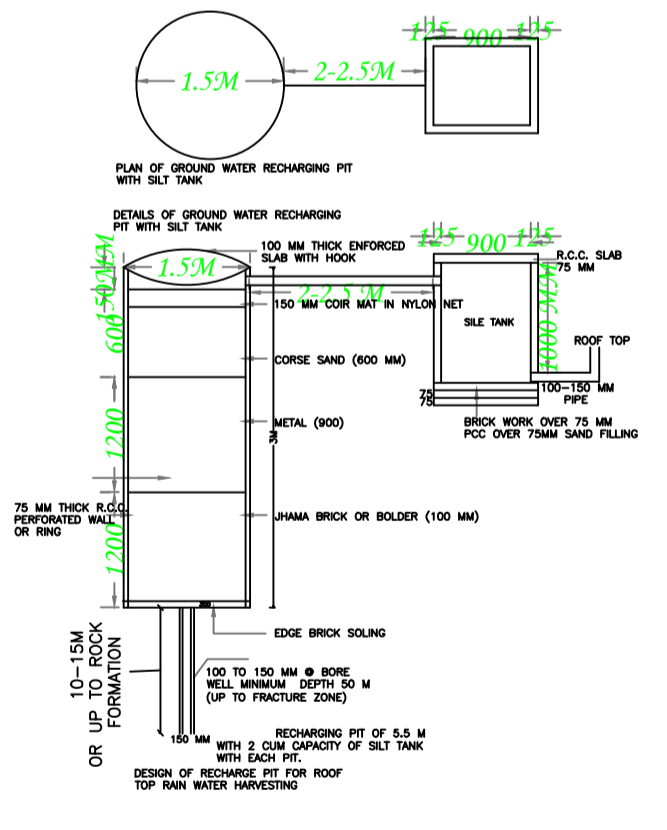

LTP NAME AND SIGNATURE	STRUCTURAL ENG'S NAME AND SIGNATURE	BUILDER NAME AND SIGNATURE	DIGITAL SIGNATURE
DEEPAK DIWAN GUNPC/ARC/0003/2017			