

Proposal Basic Information	
Proposal File No.	GUNPC/BP/0051/W10/2020
Owner Name	SALOMI KERKETTA
Khata No	169
Plot No	721
Village Name	Pugu
Use	Residential
SubUse	Bungalow/ Dwelling / Non Apartment

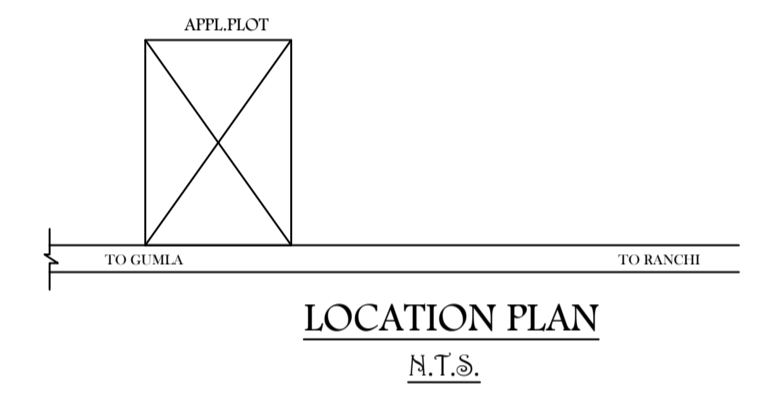

COLOR INDEX	
PLOT BOUNDARY	[Red Line]
ABUTTING ROAD	[Green Line]
PROPOSED CONSTRUCTION	[Yellow Line]
COMMON PLOT AREA	[Blue Line]
ROAD WIDENING AREA	[Orange Line]
EXISTING (To be retained)	[Grey Line]
EXISTING (To be demolished)	[Black Line]

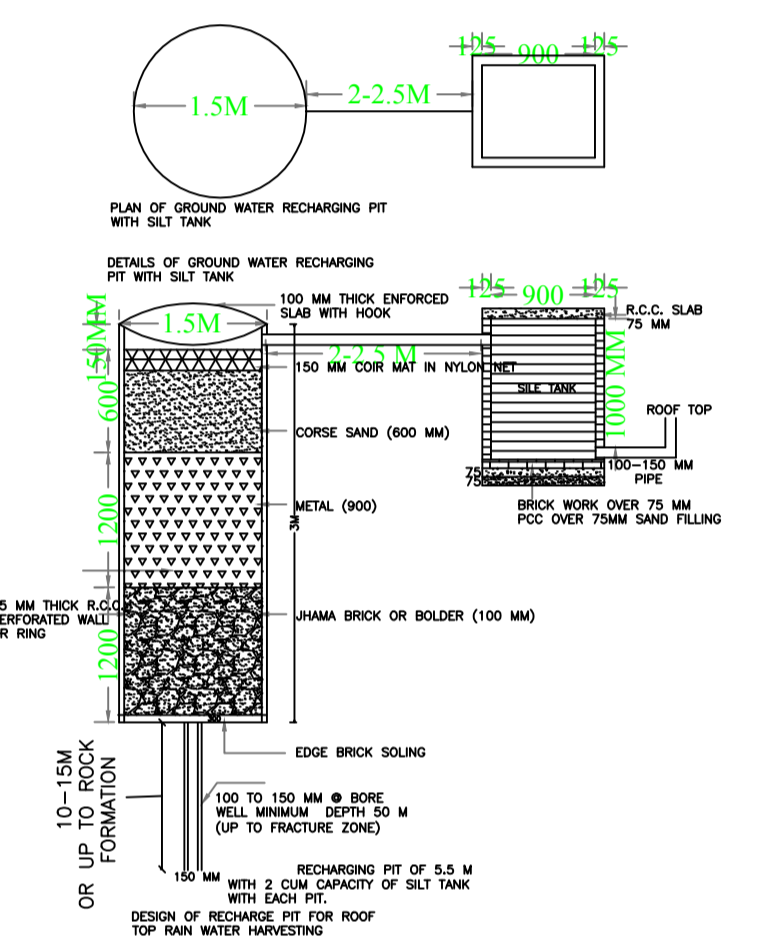
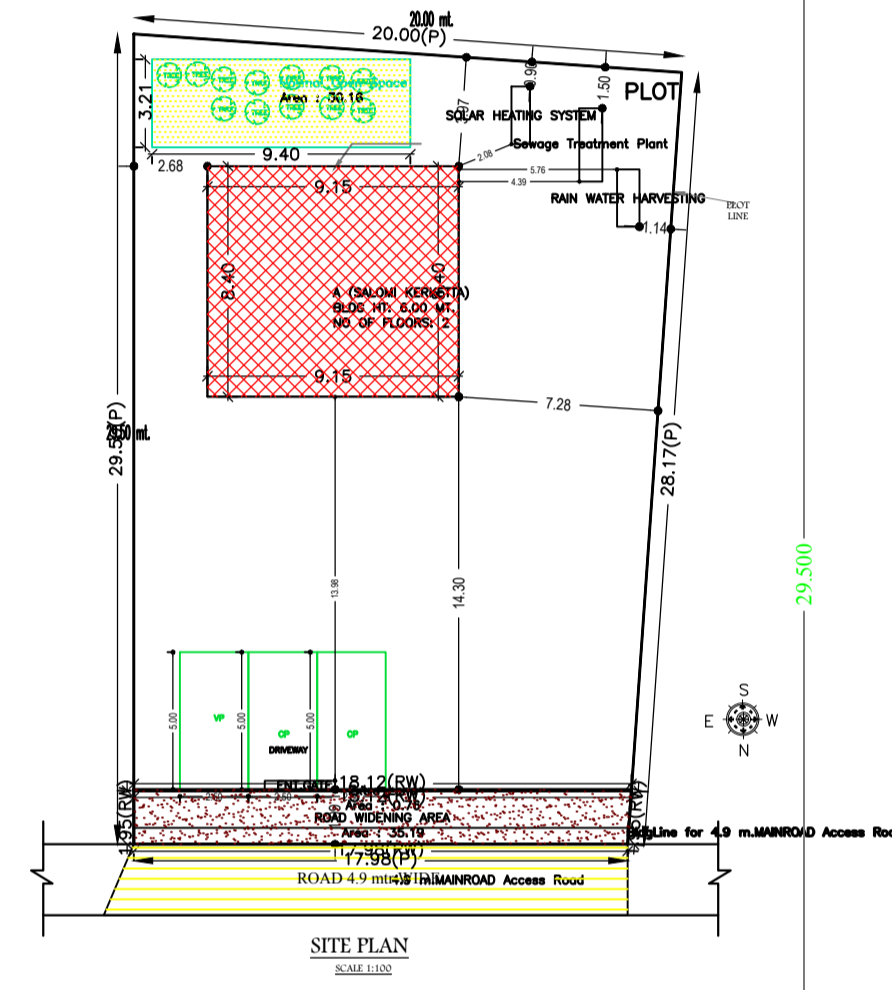
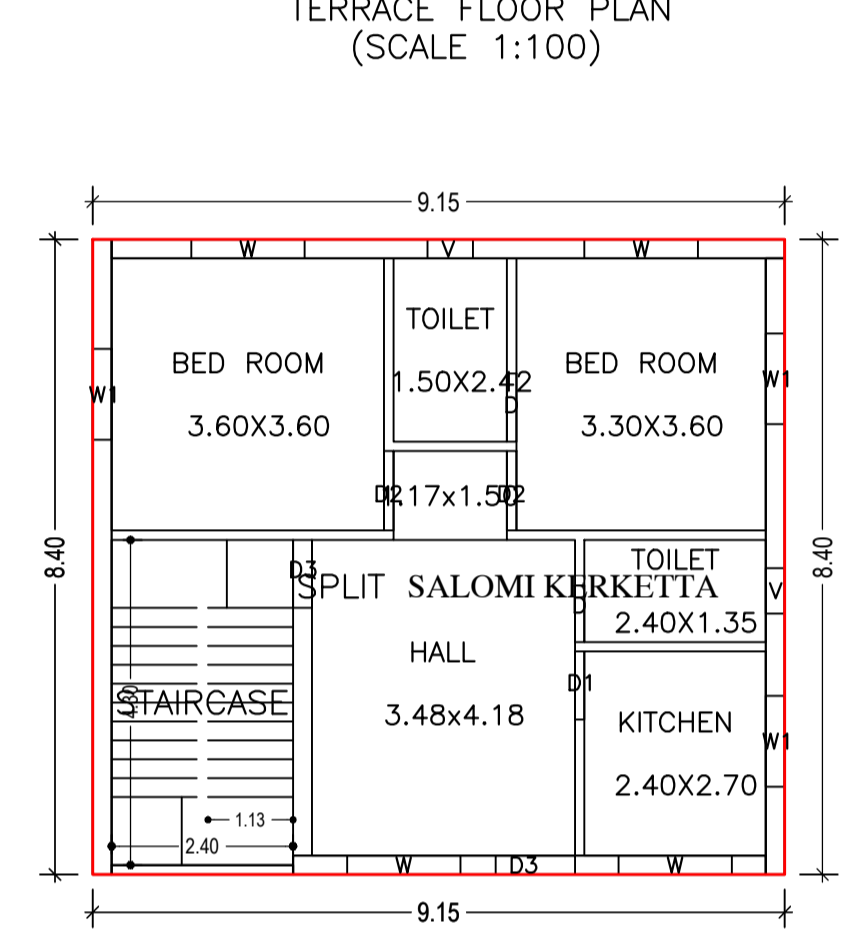
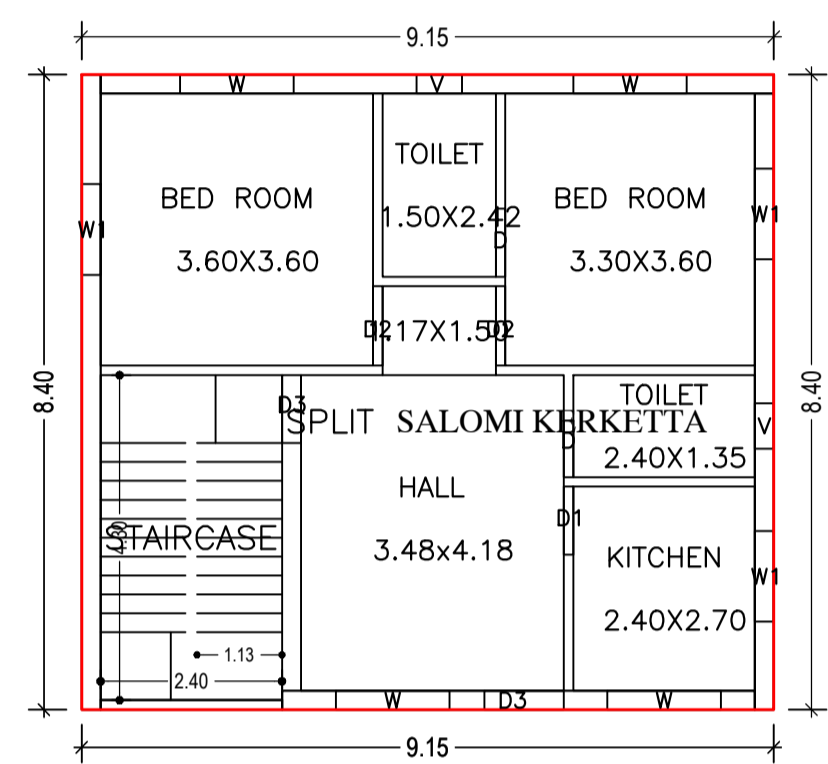
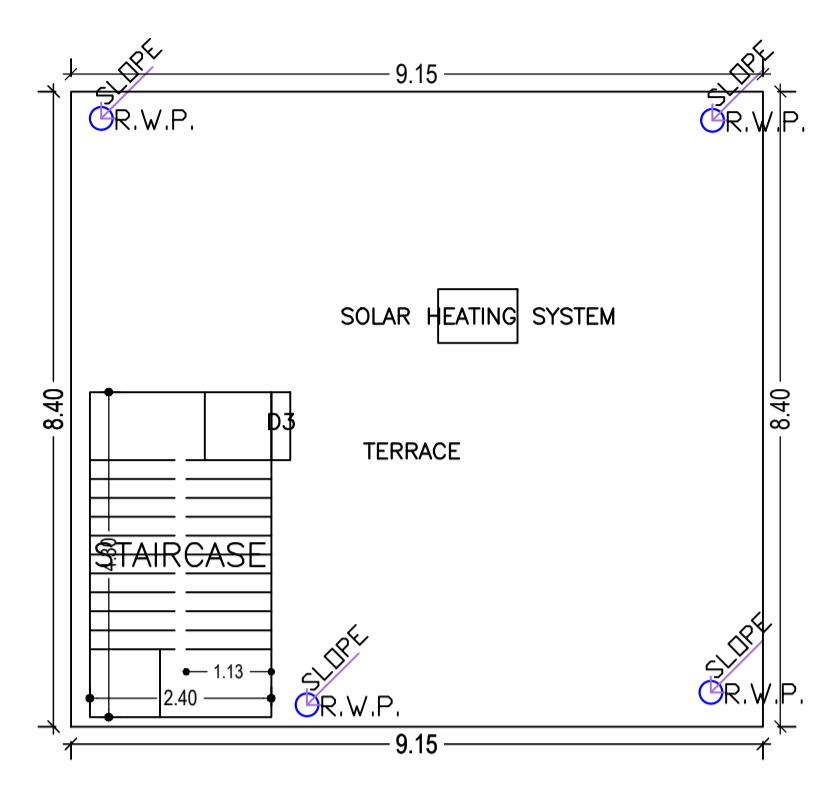
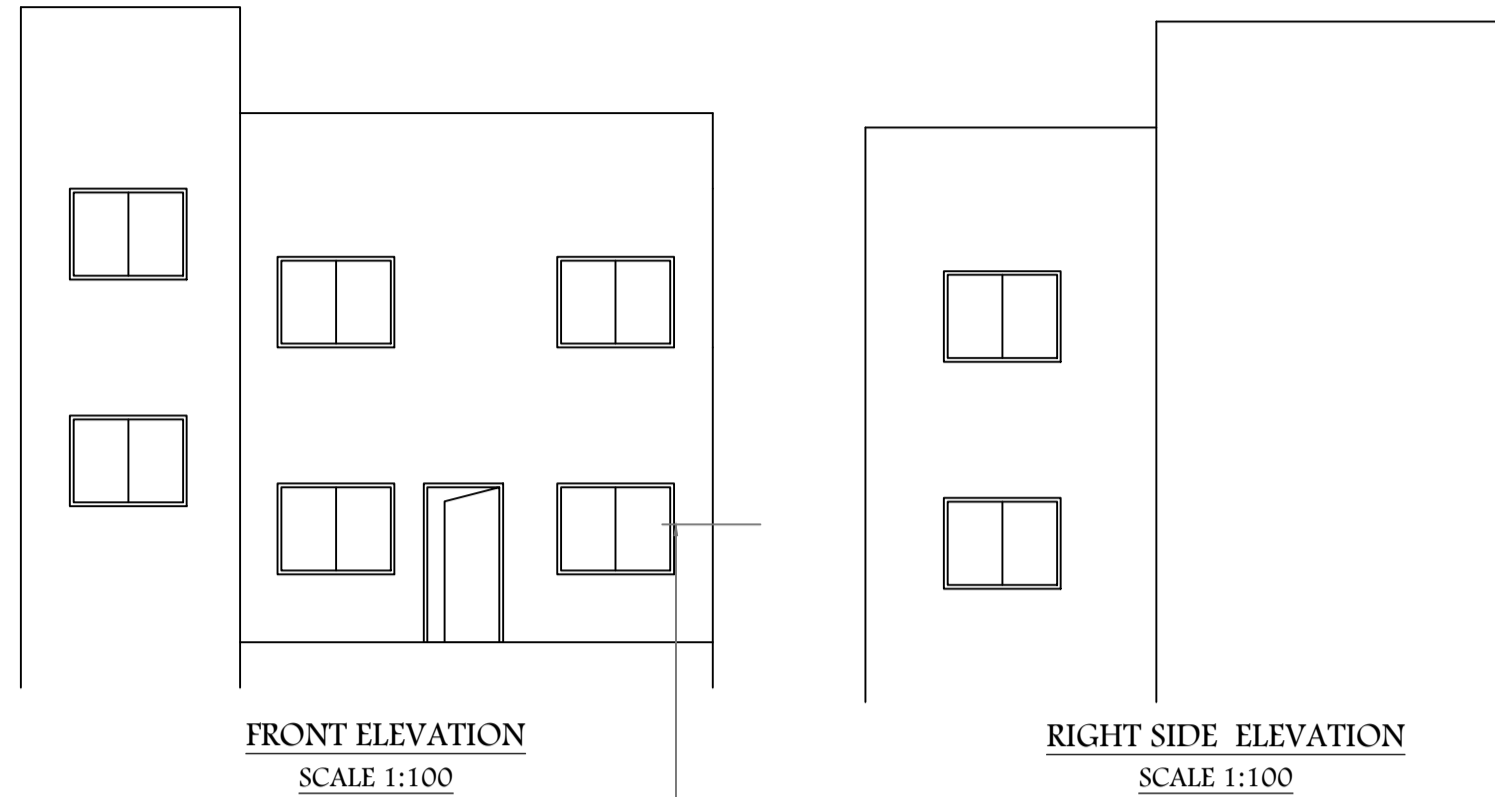
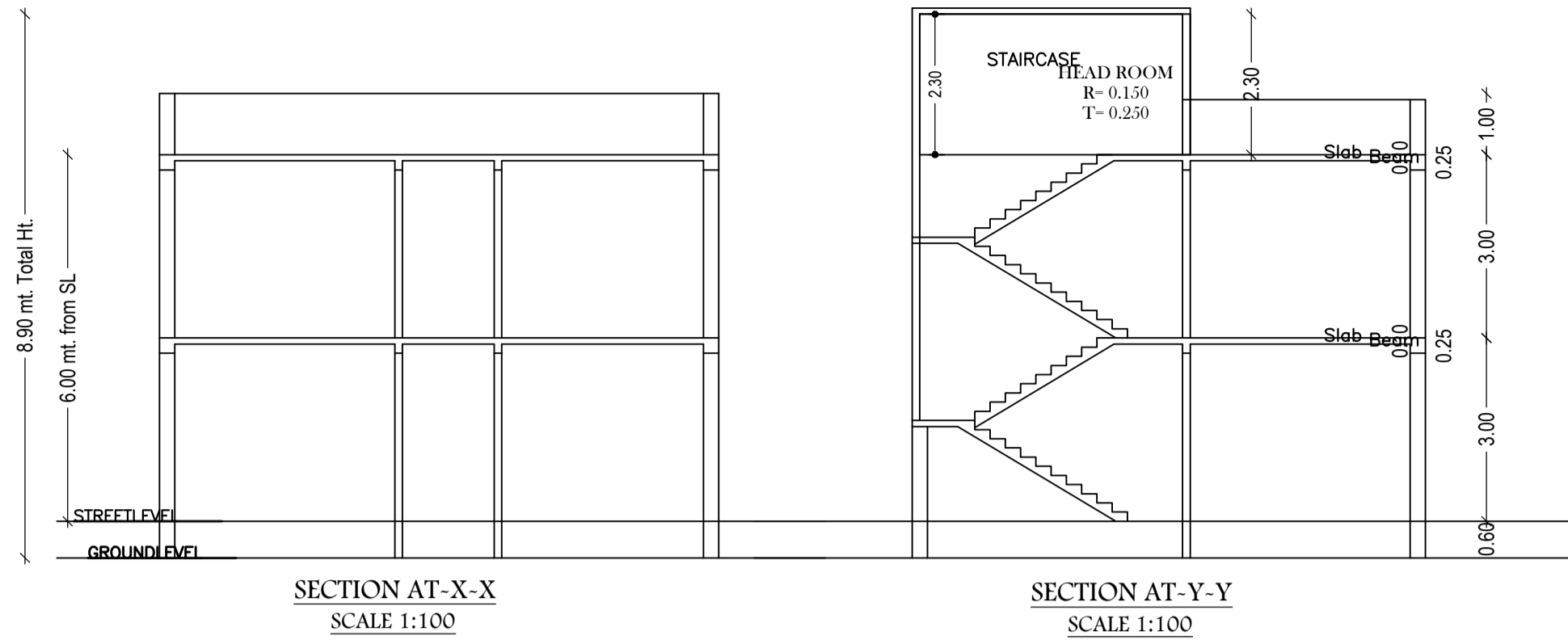
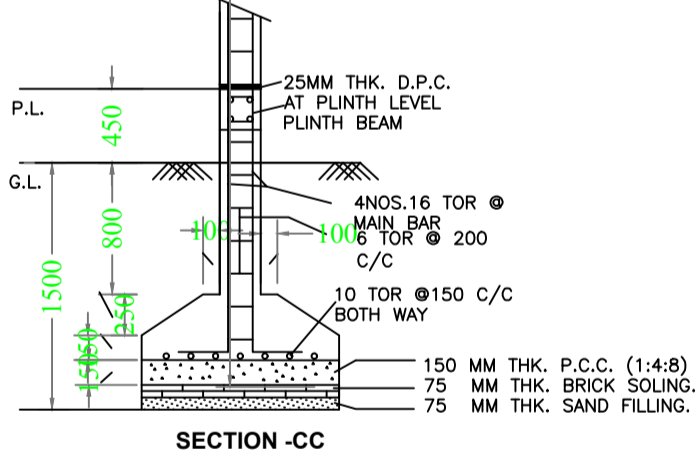
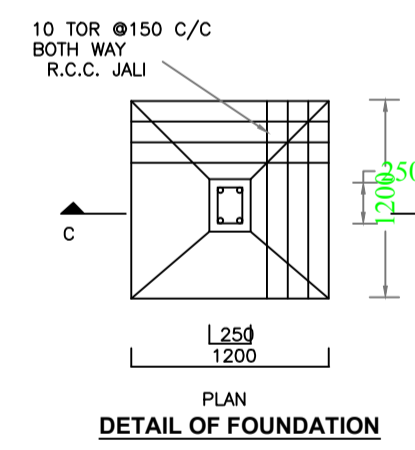
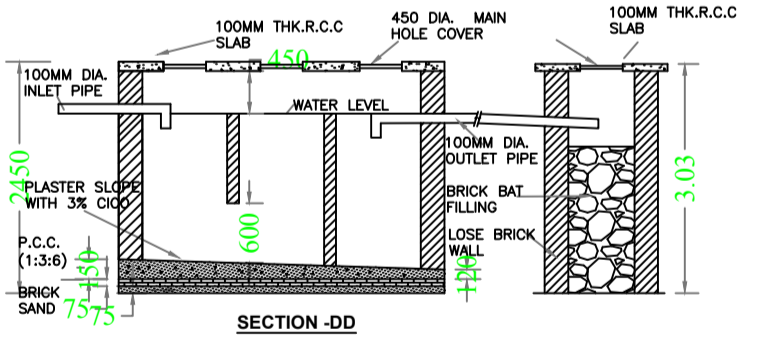
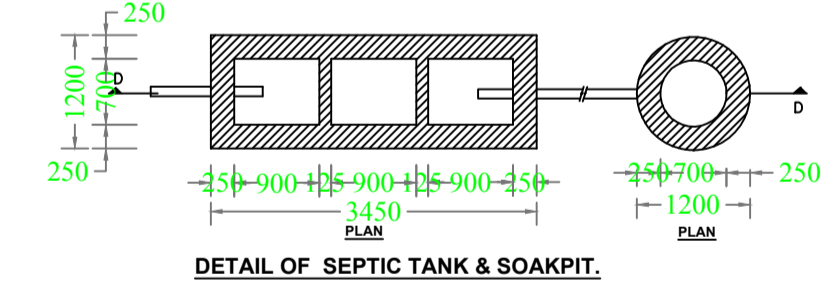

SCHEDULE OF DOOR:				
BUILDING NAME	NAME	LENGTH	HEIGHT	NOS
A (SALOMI KERKETTA)	D	0.75	2.10	02
A (SALOMI KERKETTA)	D	0.90	2.10	02
A (SALOMI KERKETTA)	D1	0.90	2.10	02
A (SALOMI KERKETTA)	D3	0.90	2.10	02
A (SALOMI KERKETTA)	D2	1.05	2.10	04
A (SALOMI KERKETTA)	D3	1.05	2.10	02

SCHEDULE OF WINDOW/VENTILATION:				
BUILDING NAME	NAME	LENGTH	HEIGHT	NOS
A (SALOMI KERKETTA)	V	0.60	1.20	04
A (SALOMI KERKETTA)	W1	1.20	1.20	06
A (SALOMI KERKETTA)	W	1.50	1.20	08

AREA STATEMENT GUMLA NAGAR PARISHAD		VERSION NO.: 1.0.53
PROJECT DETAIL:		VERSION DATE: 16/10/2020
Region: JHARKHAND URBAN LOCAL BODIES	Plot Use: Residential	
District: GUMLA	Plot SubUse: Bungalow/ Dwelling / Non Apartment	
Authority: GUMLA NAGAR PARISHAD	PlotNearby/ReligiousStructure: NA	
Tinward No: GUNPCBP/0051/W10/2020	PlotSubPlot No: 721	
Application Type: General Proposal	North: -	
Project Type: Building Permission	South: -	
Nature of Development: New	East: -	
Location of Development Area: Old Area	West: -	
AREA DETAILS:		SQ. MT.
AREA OF PLOT (Minimum)	(A)	546.90
Deduction for NetPlot Area		
Road Widening Area		35.19
Total		35.19
NET AREA OF PLOT(Gross Plot Area - Deduction from Gross Plot area)	(A-Deductions)	511.71
Deduction for Balance Plot Area(from Gross Plot Area)		
Road Widening Area		35.19
Common Plot		30.16
Total		65.35
BALANCE AREA OF PLOT(Net Plot Area - Recreational/Amenity space)	(A-Deductions)	481.55
PLOT AREA FOR COVERAGE(Net Plot Area)	(A-Deductions)	511.71
Plot Area for FAR (Net Plot Area + RoadWidening Area)	(A-Deductions)	511.71
COVERAGE CHECK		
Permissible Coverage area (60.00 %)		307.03
Proposed Coverage Area (15.03 %)		76.89
Total Prop. Coverage Area (15.03 %)		76.89
Balance coverage area (44.98 %)		230.14
FAR CHECK		
Perm. FAR Area (1.80)		921.08
Total Perm. FAR area		921.08
Residential FAR		153.79
Proposed FAR Area		153.79
Total Proposed FAR Area		153.79
Consumed FAR (Factor)		0.30
Balance FAR Area		767.29
BUILT UP AREA CHECK		
Total Proposed BuiltUp Area		153.78
ARCHITECT (Regd)	DEEPAK DIWAN	
ENGINEER (Regd)		
SUPERVISOR (Regd)		
OWNER (Regd)	SALOMI KERKETTA	
DEVELOPMENT AUTHORITY		LOCAL BODY

FAR & Tenement Details (Table 4c-1)

Building	No. of Same Bldg	Total Built Up Area (Sq.mt.)	Proposed FAR Area (Sq.mt.) Resi.	Total FAR Area (Sq.mt.)	Total Consumed Additional FAR Area (Sq.mt.)	Tnmt (No.)
A (SALOMI KERKETTA)	1	153.78	153.78	153.78	153.78	01
Grand Total :	1	153.78	153.78	153.78	153.78	01

Building :A (SALOMI KERKETTA)

Floor Name	Total Built Up Area (Sq.mt.)	Proposed FAR Area (Sq.mt.) Resi.	Total FAR Area (Sq.mt.)	Total Consumed Additional FAR Area (Sq.mt.)	Tnmt (No.)
Ground Floor	76.89	76.89	76.89	76.89	01
First Floor	76.89	76.89	76.89	76.89	00
Terrace Floor	0.00	0.00	0.00	0.00	00
Total :	153.78	153.78	153.78	153.78	01
Total Number of Same Buildings :	1				
Total :	153.78	153.78	153.78	153.78	01

Buildingwise Floor FAR Details

Floor Name	Building Name		Total	
	Proposed Built Up Area (Sq.mt.)	Proposed FAR Area (Sq.mt.)	Total Proposed Built Up Area (Sq.mt.)	Total FAR Area (Sq.mt.)
Ground Floor	76.89	76.89	76.89	76.89
First Floor	76.89	76.89	76.89	76.89
Terrace Floor	0.00	0.00	0.00	0.00
Total :	153.78	153.78	153.78	153.78

Building USE/SUBUSE Details

Building Name	Building Use	Building SubUse	Building Structure
A (SALOMI KERKETTA)	Residential	Bungalow/ Dwelling / Non Apartment	Non-Highrise

UnitBUA Table for Building :A (SALOMI KERKETTA)

FLOOR	Name	UnitBUA Type	UnitBUA Area	Carpet Area	No. of Rooms	No. of Tenement
GROUND FLOOR PLAN	SPLIT SALOMI KERKETTA	FLAT	153.79	137.33	6	1
FIRST FLOOR PLAN	SPLIT SALOMI KERKETTA	FLAT	0.00	0.00	6	0
Total:	-	-	153.79	137.33	12	1

LTP NAME AND SIGNATURE STRUCTURAL ENG'S NAME AND SIGNATURE BUILDER NAME AND SIGNATURE DIGITAL SIGNATURE

DEEPAK DIWAN GUNPC/ARC/0003/2017			
-------------------------------------	--	--	--